

Current Clamps

Catalogue



ABOUT THE CHAUVIN ARNOUX GROUP

Founded in 1893 in Paris, France, **CHAUVIN ARNOUX** has, over the years, developed its expertise in the design, manufacture and marketing of instruments for measurement purposes used by professionals.

From portable instrumentation to fixed electrical and energy performance equipment, and from control of the entire thermal process chain to industrial metrology, the **CHAUVIN ARNOUX** Group's range of products and services addresses every customer challenge across all sectors (trade, industry, public sector, etc.).

*"CHAUVIN ARNOUX is a major force
on the measurement market
in France and internationally."*

Your partner:

- energy performance
- regulatory testing
- environmental measurements
- installation supervision and sizing



A few figures:

- 100 million euros of sales revenues
- 900 employees
- 6 R&D departments worldwide
- 10 subsidiaries spread across the world
- 7 production sites
- 11 % of revenues invested in R&D

Current Clamps

Catalogue

Clamps and flexible probes Accessories

• Theoretical overview	A
• Selection guides	B
AC	B.1
AC/DC	B.2
• AC measurement	C
MINI clamps	C.1
MN clamps	C.2
Y clamps	C.3
C clamps	C.4
D clamps	C.5
B clamps	C.6
MiniFlex	C.7
AmpFlex®	C.8
• AC/DC measurements	D
E clamps	D.1
MH clamps	D.2
PAC clamps	D.3
Accessories	E

NOTES

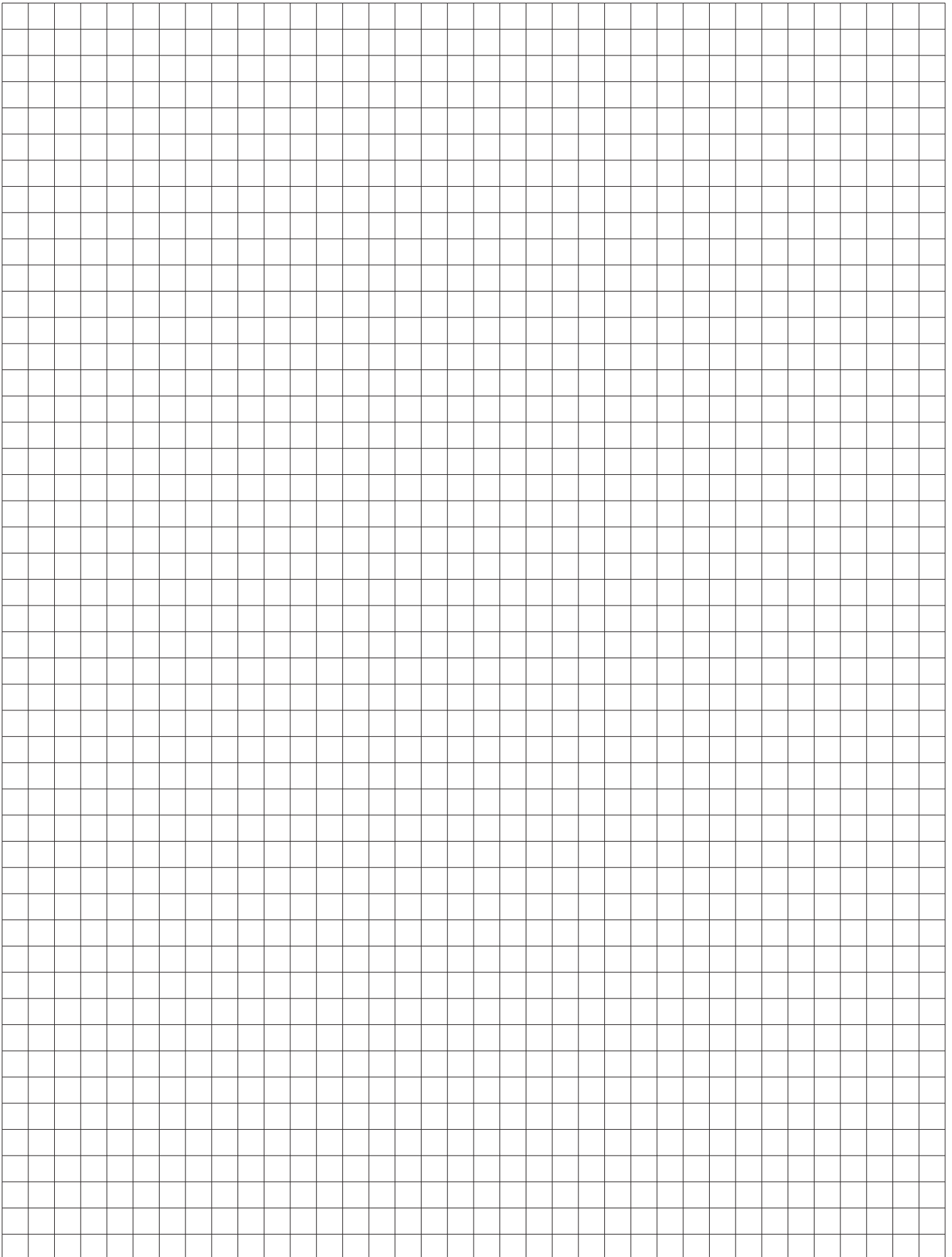

CURRENT CLAMPS

A modern method for measuring electrical currents

Introduction

Clamp are designed to extend the current measuring capabilities of multimeters, power instruments, oscilloscopes, hand-held scopes, recorders or loggers, and other diverse instruments.

The clamp is placed around the current-carrying conductor to perform non-contact current measurements without interrupting the circuit under test. The clamp outputs current or voltage signals directly proportional to the measured current, thereby providing current measuring and displaying capabilities to instruments with low current or voltage inputs.

When making a measurement, the current carrying conductor circuit is not broken and remains electrically isolated from the instrument's input terminals. As a result, the instrument's low input terminal may be either floated or earthed. It is not necessary to interrupt the power supply when using a current clamp for taking measurements, so costly downtime can be eliminated.

True RMS measurements within the clamp's frequency response are possible by using most Chauvin Arnoux current clamps with a true RMS multi meter.

In most cases, RMS measurements are not limited by the clamps, but by the instrument to which they are connected. Best results are provided by clamps offering inherent high accuracy, good frequency response, and minimal phase shift. Several Chauvin Arnoux® clamps are patented for their unique circuitry and design.

AC current clamps

How the transformer clamp works:

AC current clamps are, in most cases, a specific type of current transformer. A transformer (figure 1) is essentially two coils wound on a common iron core. A current I_1 is applied through the coil B_1 , inducing through the common core a current I_2 in the coil B_2 .

The number of turns in each coil and currents I_1 and I_2 are related by the following equation:

$$N_1 \times I_1 = N_2 \times I_2$$

where N_1 and N_2 are the number of turns in each coil. From this relationship:

$$I_2 = N_1 \times I_1 / N_2 \text{ or } I_1 = N_2 \times I_2 / N_1.$$

• Figure 1

This same principle is applied to a current clamp (figure 2). The jaws of the clamp contain the common magnetic circuit and the secondary winding B_2 . The

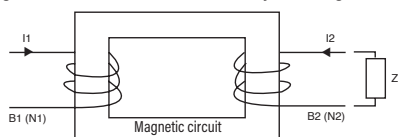

conductor around which the clamp is secured forms the primary winding B_1 (a single turn), through which the current I_1 for measurement flows.

The current sensor clamped around the conductor provides an output proportional to the number of turns in its coil B_2 , such that:

$$I_2 \text{ (current in the clamp)} = N_1 \times I_1 / N_2$$

where $N_1 = 1$, hence $I_2 = I_1 / N_2$

(N_2 is the number of turns in the clamp jaw).

It is often difficult to measure I_1 directly because of currents which are too high to be fed directly into a meter or simply because breaking into the circuit is not possible. To provide a manageable output level, a known number of turns is made on the clamp's coil.

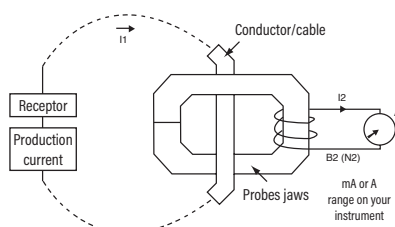

• Figure 2

The number of turns in the winding of the clamp is usually a whole number (e.g. 100, 500 or 1,000). If N_2 equals 1,000, then the clamp has a ratio of N_1/N_2 or $1/1,000$, which is expressed as 1,000:1.

Another way to express this ratio is to say that the clamp output is 1mA/A. The clamp's output level is 1 mA (I_2) for every 1 A in the primary conductor being measured (or, 1 A for every 1,000 A).

There are numerous other ratios possible: 500:5, 2,000:2, 3,000:1, 3,000:5, etc. for different applications.

The most common application is the use of a current clamp with a digital multi meter. Take as an example a current clamp with a ratio of 1,000:1 (model C100) with an output of 1mA/A. This ratio means that any current flowing through the probe jaws will result in a current flowing at the output:

Conductor input	Clamp output
1,000 A	1 A
750 A	750 mA
250 A	250 mA
10 A	10 mA

The clamp output is connected to a multimeter set on the AC current range to handle the clamp output. Then, to determine the current in the conductor, multiply the reading of the multimeter by the ratio (e.g., 150 mA read on the 200 mA multimeter range represents 150 mA x 1,000 = 150 A in the conductor measured).

Current clamps may be used with other instruments with current ranges, provided that these instruments have the required input impedance (see figure 3).

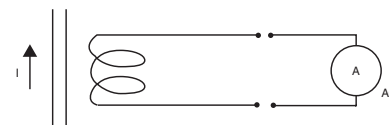

• Figure 3

Current clamps may also have AC or DC voltage outputs to accommodate current measurements with instruments (loggers, scopes, etc.) with voltage ranges only (figures 4 and 5).

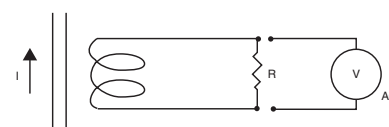

• Figure 4

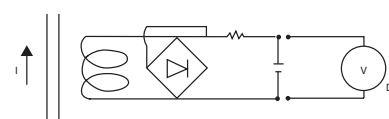

• Figure 5

This is simply done by conditioning the current clamp output inside the clamp to provide voltage (e.g., model Y4N or MINI09). In these cases, the probe mV output is proportional to the measured current.

CURRENT CLAMPS

A modern method for measuring electrical currents

Operating principle:

The AmpFlex® and MiniFlex sensors are based on the principle of the Rogowski coil. The primary circuit is constituted by the conductor carrying the alternating current to be measured, while the secondary is formed by a special coil wound on a flexible support.

At its terminals, this coil develops a voltage proportional to the derivative of the primary current to be measured:

$$u = \frac{\mu_0 \cdot n}{2\pi \cdot r} \times S \cdot \frac{di}{dt}$$

where μ_0 = vacuum permeability
 S = surface area of a turn
 n = number of turns
 r = core radius

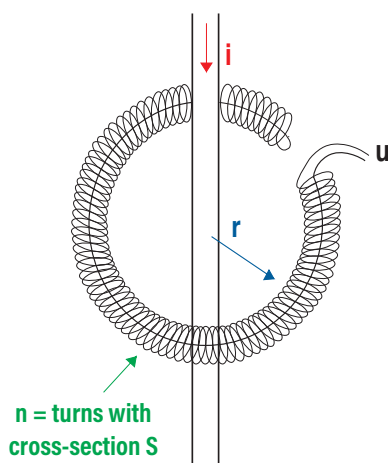

• Rogowski coil

This AC voltage u is then passed via a screened cable to the casing containing all the processing electronics and the battery power supply.

Because there are not magnetic circuits on these sensors, they are very lightweight and flexible. Without magnetic circuits, there is no saturation effect or overheating. This feature offers excellent linearity and low phase shift.

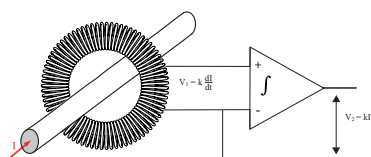

AC/DC clamp-on current probes

Theory of Operation (Hall effect)

Unlike on traditional AC transformers, AC/DC current measurement is often achieved by measuring the strength of a magnetic field created by a current-carrying conductor in a semi-conductor chip using the Hall-effect principle.

When a thin semiconductor (figure 6) is placed at right angles to a magnetic field (B), and a current (I_d) is applied to it, a voltage (V_h) is developed across the semiconductor.

This voltage is known as the Hall voltage, named after the US scientist Edwin Hall who first reported the phenomenon.

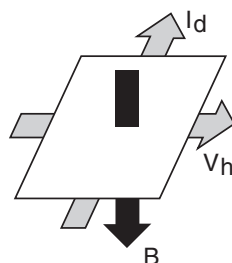

• Figure 6

When the Hall device drive current (I_d) is held constant, the magnetic field (B) is directly proportional to the current in a conductor. Thus, the Hall output voltage (V_h) is representative of that current.

Such an arrangement has two important benefits for universal current measurement.

First, since the Hall voltage is not dependent on a reversing magnetic field, but only on its strength, the device can be used for DC measurement.

Second, when the magnetic field strength varies due to varying current flow in the conductor, response to change is instantaneous.

Thus, complex AC wave forms may be detected and measured with high accuracy and low phase shift.

The basic construction of a clamp jaw assembly is shown in figure 7, (note: one or two Hall generators are used depending on the type of current clamp).

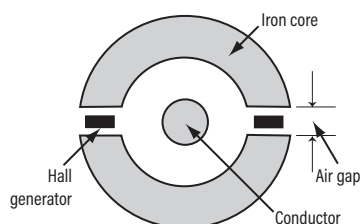

• Figure 7

The Chauvin Arnoux AC/DC current clamps were developed using the above principle, together with patented electronic circuitry incorporating signal conditioning for linear output and a temperature compensation network. These have a wide dynamic range and frequency response with highly accurate linear output, for application in all areas of current measurement up to 1,500A. Direct currents can be measured without the need of expensive, power-consuming shunts, and alternating currents up to several kHz can be measured accurately to respond to the requirements of complex signals and RMS measurements.

The clamp outputs are in mV (mV DC when measuring DC, and mV AC when measuring AC) and may be connected to most instruments with a voltage input, such as multimeters, loggers, oscilloscopes, handheld scopes, recorders, etc.

The AC/DC clamps also offer the opportunity to display or measure True RMS in AC or AC+DC.

AC or DC current measurement

- Connect the clamp to the instrument
- Select the function and range
- Clamp the clamp around a single conductor
- Read the conductor's current value

Examples (figure 8):

AC: clamp model: Y2N
 Ratio: 1,000:1
 Output: 1 mA AC/A AC
 Multimeter: set to the 200 mA AC calibre
 Multimeter reading: 125 mA AC
 Current in conductor: 125 mA x 1,000 = 125 A AC

DC: clamp model: PAC 26
 1 mV DC/A DC (Hall sensor)
 Multimeter: set to the 200 mV DC calibre
 Multimeter reading: 160 mV DC
 Current in conductor: 160 A DC

AC: clamp model: PAC 16
 Output: 1 mV AC/A AC (Hall sensor)
 Multimeter: set to the 200 mV AC calibre
 Multimeter reading: 120 mV AC
 Current in conductor: 120 A AC

CURRENT CLAMPS

A modern method for measuring electrical currents

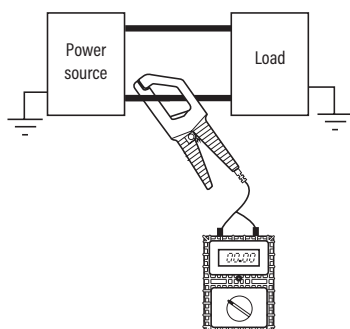

• Figure 8

Measurements of low currents and leakage currents

When the current to be measured is too low for the clamp or better accuracy is required, it is possible to insert the conductor multiple times through the probe jaws. The value of the current is the ratio of the reading to the number of turns.

Examples (figure 9):

Clamp model: C100

Ratio: 1,000:1

Multimeter: set to 200 mA AC range

Turns in clamp jaw: 10

Multimeter reading: 60 mA AC

Current in conductor:

$60 \text{ mA} \times 1,000 / 10 = 6,000 \text{ mA} = 6 \text{ A}$

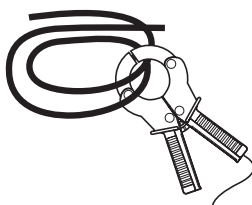

• Figure 9

When the clamp is placed around two conductors with different polarities, the resulting reading will be the difference between the two currents. If the currents are the same, the reading will be zero (figure 10).

When a reading other than zero is obtained, the reading is the amount of leakage current on the load.

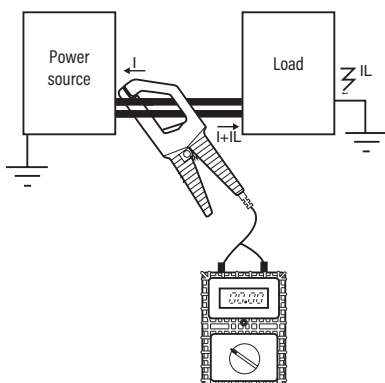

• Figure 10

To measure low currents or leakage, you need a clamp which will measure low values, such as the model B102 or C173. However, earth leakage currents may also be measured directly with the simple model (figure 11).

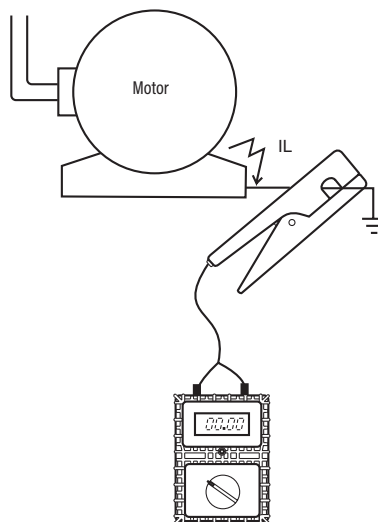

• Figure 11

Examples: figure 11

MINI 05

Ratio: 1 mV/mA AC

Multimeter: set to 200 mA AC range

Multimeter reading: 10 mV AC

Leakage current: 10 mA AC

Select the appropriate current clamp model

Answering the following questions will help you to select the appropriate clamp for your applications:

- Determine if you are measuring AC or DC (DC current clamps are categorized as AC/DC because they measure both).
- What is the maximum current you will measure, and what is the minimum current you will measure?
Check that the accuracy at low levels is appropriate, or select a low-current measurement clamp. Most clamps perform with greater accuracy at the upper end of their range.
- What size conductor will you clamp onto?
This parameter determines the clamp jaw size needed.
- What type of clamp output do you need or can you work with (mA, mV, AC, DC, etc.)?
Check the maximum receiver impedance to ensure that the clamp will perform to specifications.



Other factors you may want to consider:

- What is the working voltage of the conductor to be measured?
Chauvin Arnoux clamps must not be used above 600 volts (see specifications).
- What type of termination do you need: sockets, banana leads or BNC leads ?
- Will the probe be used for harmonics or power clamp ?
Look at the frequency specifications and phase shift specifications.

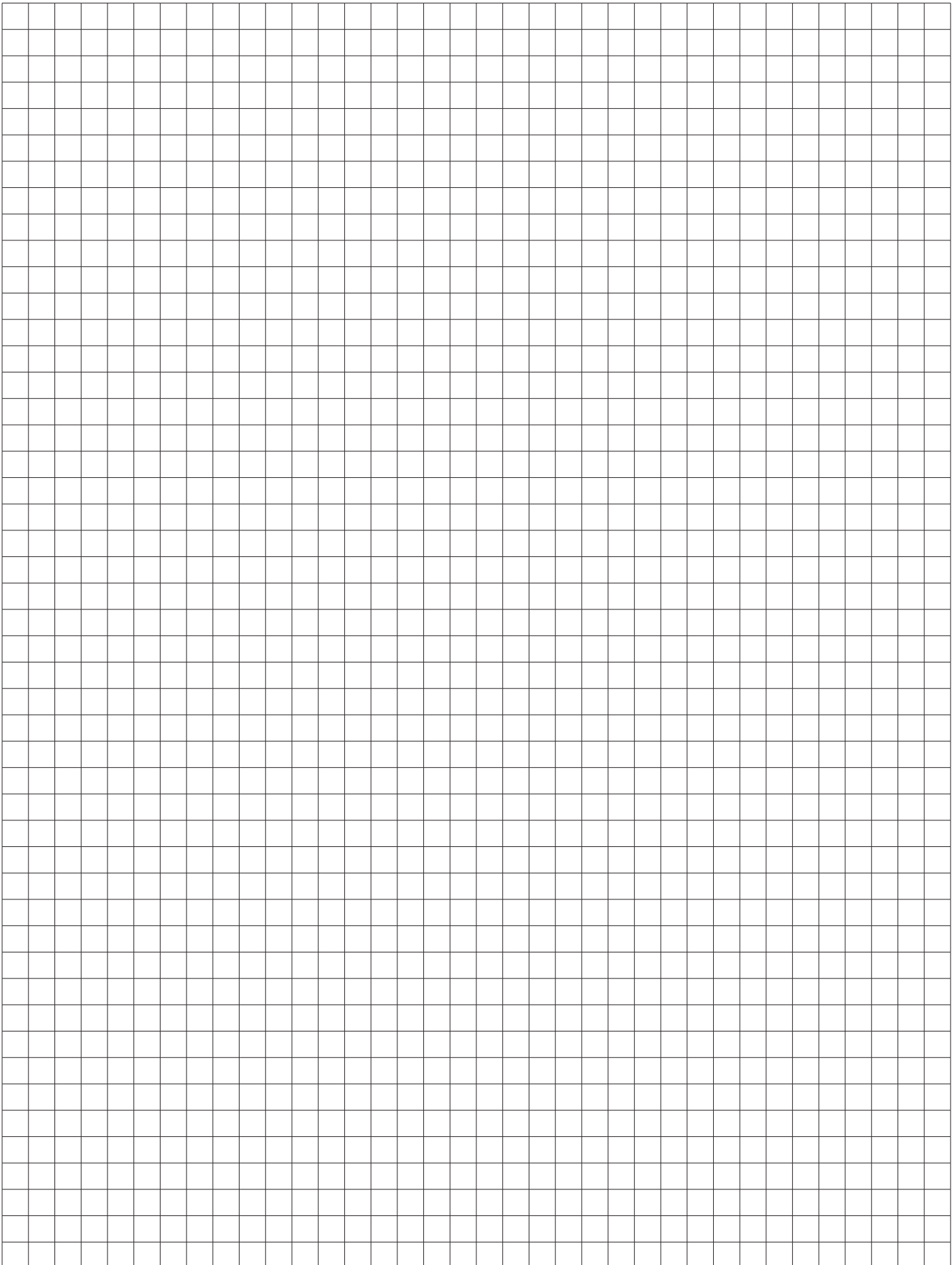
NOTES

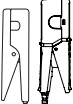

AC CURRENT MEASUREMENT

Series	Model	Input						Output - Connections				Specific features					To order				
		Measuring range ⁽¹⁾						Current	Voltage	Lead + ø 4 mm safety connectors	Socket ø 4 mm	BNC connector (coaxial)	Transformation ratio (input/output)	Output protected against voltage swells	Automatic DC voltage	Measurement of power (slight phase shift)		Bandwidth (frequency in Hz)	Typical accuracy		
		Very weak current	Weak current	Medium current	Strong current	AC	DC														
 Chapter C.1	MINI 01	2 A .. 150 A					●		0.15 A AC		●			1,000/1	●			48 Hz .. 500 Hz	≤ 2.5 %	P01105101Z	
	MINI 02	50 mA .. 100 A					●		0.1 A AC		●			1,000/1	●	●		48 Hz .. 10 kHz	≤ 1 %	P01105102Z	
	MINI 03	1 A .. 100 A					●			0.1 V AC	●			1 A / 1 mV				48 Hz .. 500 Hz	≤ 2 %	P01105103Z	
	MINI 05	5 mA .. 10 A 1 A .. 100 A					●			10 V AC 0.1 V AC	●			1 mA / 1 mV 1 A / 1 mV					≤ 3 % ≤ 2 %	P01105105Z	
	MINI 09	1 A .. 150 A					●			15 V DC	●			1 A / 100 mV				≤ 4 %	P01105109Z		
	MINI 102	0.05 A - 200 A					●		0.2 A AC		●			1,000/1	●			48 Hz .. 10 kHz	≤ 1 %	P01106102	
	MINI 103	0.1 A - 200 A					●			0.2 V AC	●			1 A / 1 mV	●			≤ 1.5 %	P01106103		
 Chapter C.2	MN 08	0.5 A .. 240 A					●		0.2 A AC		●			1,000/1				40 Hz .. 10 kHz	≤ 1 %	P01120401	
	MN 09	0.5 A .. 240 A					●		0.2 A AC		●			1,000/1					≤ 1 %	P01120402	
	MN 10	0.5 A .. 240 A					●		0.2 A AC		●			1,000/1	●				≤ 2 %	P01120403	
	MN 11	0.5 A .. 240 A					●		0.2 A AC		●			1,000/1	●				≤ 2 %	P01120404	
	MN 12	0.5 A .. 240 A					●			2 V AC	●			1 A / 10 mV					≤ 1 %	P01120405	
	MN 13	0.5 A .. 240 A					●			2 V AC	●			1 A / 10 mV					≤ 1 %	P01120406	
	MN 14	0.5 A .. 240 A					●			0.2 V AC	●			1 A / 1 mV					≤ 1 %	P01120416	
	MN 15	0.5 A .. 240 A					●			0.2 V AC	●			1 A / 1 mV					≤ 1 %	P01120417	
	MN 21	0.1 A .. 240 A					●		0.2 A AC		●			1,000/1	●				≤ 2 %	P01120418	
	MN 23	0.1 A .. 240 A					●			2 V AC	●			1 A / 10 mV					≤ 1.5 %	P01120419	
	MN 38	0.1 A .. 24 A					●			2 V AC		●		1 A / 100 mV					≤ 1 %	P01120407	
	MN 39	0.1 A .. 24 A					●			2 V AC	●			1 A / 100 mV					≤ 1 %	P01120408	
		0.5 A .. 240 A					●			2 V AC	●			1 A / 10 mV							
	MN 60	0.1 A .. 60 A peak					●			6 V peak		●		1 A / 100 mV					40 Hz .. 40 kHz	≤ 2 %	P01120409
		0.5 A .. 600 A peak					●			6 V peak		●		1 A / 10 mV					≤ 1.5 %		
	MN 71	10 mA .. 12 A					●			1 V AC	●			1 A / 100 mV					≤ 1 %	P01120420	
	MN 73	10 mA .. 24 A					●			2 V AC	●			1 mA / 1 mV					40 Hz .. 10 kHz	≤ 1 %	P01120421
100 mA .. 240 A					●			2 V AC	●			1 A / 10 mV				≤ 2 %					
MN 88	0.5 A .. 240 A					●			20 V DC ⁽²⁾	●	●		1 A / 100 mV				≤ 2 %	P01120410			
MN 89	0.5 A .. 240 A					●			20 V DC ⁽²⁾	●			1 A / 100 mV				≤ 2 %	P01120415			
 Chapter C.3	Y1N	4 A .. 500 A					●		0.5 A AC		●			1,000/1	●		48 Hz .. 1 kHz	≤ 3 %	P01120001A		
	Y2N	4 A .. 500 A					●		0.5 A AC		●			1,000/1	●			≤ 1 %	P01120028A		
	Y3N	4 A .. 500 A					●		5 A AC		●			100/1				≤ 3 %	P01120029A		
	Y4N	4 A .. 500 A					●			0.5 V DC ⁽²⁾	●			500 A / 0.5 V				≤ 1 %	P01120005A		
	Y7N	1 A .. 1,200 A peak					●			12 V peak		●		1 A / 1 mV				5 Hz .. 10 kHz	≤ 2 %	P01120075	

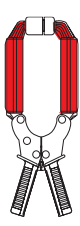

(1) The upper value corresponds to 120 % of the maximum rated value (2) Rectification of the AC signal using diodes

AC CURRENT MEASUREMENT

Series	Model	Input						Output - Connections					Specific features						To order
		Measuring range ⁽¹⁾						Current	Voltage	Lead + ø 4 mm safety connectors	Socket ø 4 mm	BNC connector (coaxial)	Transformation ratio (input/output)	Output protected against voltage swells	Automatic DC voltage	Measurement of power (slight phase shift)	Bandwidth (frequency in Hz)	Typical accuracy	
		Very weak current	Weak current	Medium current	Strong current	AC	DC												
 Chapter C.4	C100	0.1 A .. 1,200 A					●	1 A AC			●		1,000/1				30 Hz...10 kHz	≤ 0.5 %	P01120301
	C102	0.1 A .. 1,200 A					●	1 A AC			●		1,000/1	●			30 Hz...10 kHz	≤ 0.5 %	P01120302
	C103	0.1 A .. 1,200 A					●	1 A AC			●		1,000/1	●			30 Hz...10 kHz	≤ 0.5 %	P01120303
	C106	0.1 A .. 1,200 A					●		1 V AC		●		1 A / 1 mV				30 Hz...10 kHz	≤ 0.5 %	P01120304
	C107	0.1 A .. 1,200 A					●		1 V AC		●		1 A / 1 mV				30 Hz...10 kHz	≤ 0.5 %	P01120305
	C112	1 mA .. 1,200 A					●	1 A AC			●		1,000/1	●	●		30 Hz...10 kHz	≤ 0.3 %	P01120314
	C113	1 mA .. 1,200 A					●	1 A AC			●		1,000/1	●	●		30 Hz...10 kHz	≤ 0.3 %	P01120315
	C116	1 mA .. 1,200 A					●		1 V AC		●		1 A / 1 mV			●	30 Hz...10 kHz	≤ 0.3 %	P01120316
	C117	1 mA .. 1,200 A					●		1 V AC		●		1 A / 1 mV			●	30 Hz...10 kHz	≤ 0.3 %	P01120317
	C122	1 A .. 1,200 A					●	5 AAC			●		1,000/5	●			30 Hz...10 kHz	≤ 1 %	P01120306
	C148		1 A .. 300 A 1 A .. 600 A 1 A .. 1,200 A					●	5 AAC			●		250/5 500/5 1,000/5	●		48 Hz...1 kHz	≤ 2 % ≤ 1 % ≤ 1 %	P01120307
	C160		0.1 A .. 30 A peak 0.1 A .. 300 A peak 1 A .. 2,000 A peak					●		3 V peak 3 V peak 2 V peak		●		10 A / 1 V 100 A / 1 V 1,000 A / 1 V			10 Hz ...100 kHz	≤ 3 % ≤ 2 % ≤ 1 %	P01120308
C173		1 mA .. 12 A 0.01 A .. 12 A 0.1 A .. 120 A 1 A .. 1,200 A					●		1 V AC		●		1 A / 1 V 10 A / 1 V 100 A / 1 V 1,000 A / 1 V			10 Hz...3 kHz	≤ 0.7 % ≤ 0.5 % ≤ 0.3 % ≤ 0.2 %	P01120309	
 Chapter C.5	D30N		1 A .. 3,600 A					●	1 AAC		●		3,000/1	●	●	30 Hz...5 kHz	≤ 0.5 %	P01120049A	
	D30CN		1 A .. 3,600 A					●	1 AAC		●		3,000/1	●	●	30 Hz...5 kHz	≤ 0.5 %	P01120064	
	D31N		1 A .. 600 A 1 A .. 1,200 A 1 A .. 1,800 A					●	1 AAC		●		500/1 1,000/1 1,500/1	●		30 Hz...1.5 kHz	≤ 3 % ≤ 1 % ≤ 0.5 %	P01120050A	
	D32N		1 A .. 1,200 A 1 A .. 2,400 A 1 A .. 3,600 A					●	1 AAC		●		1,000/1 2,000/1 3,000/1	●	●	30 Hz...1 kHz	≤ 1 % ≤ 0.5 % ≤ 0.5 %	P01120051A	
	D33N		1 A .. 3,600 A					●	5 AAC		●		3,000/5			30 Hz...5 kHz	≤ 1 %	P01120052A	
	D34N		1 A .. 600 A 1 A .. 1,200 A 1 A .. 1,800 A					●	5 AAC		●		500/5 1,000/5 1,500/5			30 Hz...1.5 kHz	≤ 3 % ≤ 1 % ≤ 0.5 %	P01120053A	
	D35N		1 A .. 1,200 A 1 A .. 2,400 A 1 A .. 3,600 A					●	5 AAC		●		1,000/5 2,000/5 3,000/5		●	30 Hz...1.5 kHz	≤ 1 % ≤ 0.5 % ≤ 0.5 %	P01120054A	
	D36N		1 A .. 3,600 A					●	3 AAC		●		3,000/3	●	●	30 Hz...1.5 kHz	≤ 0.5 %	P01120055A	
	D37N		0.1 A .. 36 A 1 A .. 360 A 1 A .. 3,600 A					●		3 V AC		●		30 A / 3 V 300 A / 3 V 3,000 A / 3 V			30 Hz...5 kHz	≤ 2 %	P01120056A
	D38N		1 A .. 90 A peak 1 A .. 900 A peak 1 A .. 9,000 A peak					●		0.9 V peak		●		1 A / 10 mV 1 A / 1 mV 1 A / 0.1 mV			30 Hz...50 kHz	≤ 2 %	P01120057A

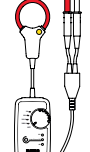
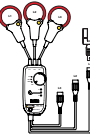

(1) The higher value corresponds to 120% of the maximum nominal value.

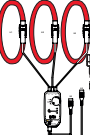
AC CURRENT MEASUREMENT

Series	Model	Input				Output - Connections				Specific features					To order		
		Measuring range ⁽¹⁾				Current	Voltage	Lead + ø 4 mm safety connectors	Socket ø 4 mm	BNC connector (coaxial)	Transformation ratio (input/output)	Output protected against voltage swells	Automatic DC voltage	Measurement of power (slight phase shift)		Bandwidth (frequency in Hz)	Typical accuracy
		Very weak current	Weak current	Medium current	Strong current												
 Chapter C.6	B102	500 µA .. 4 A 0.5 A .. 400 A				4 V AC 0.4 V AC	●			1 mA / 1 mV 1 A / 1 mV			10 Hz .. 1 kHz	≤ 0.5 % ≤ 0.35 %	P01120083		
 Chapter C.7	MA110 3-30-300-3,000/3 (17 cm / ø 4.5 cm)	0.08 A - 3A 0.5 A .. 30 A 0.5 A .. 300 A 0.5 A .. 3,000 A				3 V AC	●			1 V/A 100 mV/A 10 mV/A 1 mV/A			10 Hz .. 10 kHz 10 Hz .. 20 kHz 10 Hz .. 20 kHz 10 Hz .. 20 kHz	≤ 1 %	P01120660		
	MA110 3-30-300-3,000/3 (25 cm / ø 7 cm)										P01120661						
	MA110 3-30-300-3,000/3 (35 cm / ø 10 cm)										P01120662						
 Chapter C.7	MA130 30-300-3,000/3 (27 cm / ø 7 cm)	0.5 A .. 30 A 0.5 A .. 300 A 0.5 A .. 3,000 A				3 V AC			●	100 mV/A 10 mV/A 1 mV/A		●	10 Hz .. 20 kHz	≤ 1 %	P01120663		
 Chapter C.7	MA200 30-300/3 (17 cm)	0.5 A .. 45 A peak 0.5 A .. 450 A peak				4.5 V peak			●	100 mV/A 10 mV/A			5 Hz .. 1 MHz	≤ 1 % + 0.3 A	P01120570		
	MA200 30-300/3 (25 cm)	0.5 A .. 45 A peak 0.5 A .. 450 A peak				4.5 V peak			●	100 mV/A 10 mV/A				≤ 1 % + 0.3 A	P01120571		
	MA200 3,000/3 (35 cm)	5 A .. 4500 A peak				4.5 V peak			●	1 mV/A				≤ 1 % + 0.3 A	P01120572		
 Chapter C.8	A110 3-30-300-3,000/3 (45 cm / ø 14 cm)	0.08 A - 3 A 0.5 A .. 30 A 0.5 A .. 300 A 0.5 A .. 3,000 A				3 V AC	●			1 V/A 100 mV/A 10 mV/A 1 mV/A		●	10 Hz .. 10 kHz 10 Hz .. 20 kHz 10 Hz .. 20 kHz 10 Hz .. 20 kHz	≤ 1 %	P01120630		
	A110 3-30-300-3,000/3 (80 cm / ø 25 cm)							3 V AC	●						●	≤ 1 %	P01120631
	A110 30-300-3,000-30,000/3 (120 cm / ø 38 cm)							3 V AC	●					100 mV/A 10 mV/A 1 mV/A 0.1 mV/A		●	10 Hz .. 5 kHz 10 Hz .. 20 kHz 10 Hz .. 20 kHz 10 Hz .. 20 kHz
 Chapter C.8	A130 30-300-3,000/3 (80 cm / ø 25 cm)	0.5 A .. 30 A 0.5 A .. 300 A 0.5 A .. 3,000 A				3 V AC			●	100 mV/A 10 mV/A 1 mV/A		●	10 Hz .. 20 kHz	≤ 1 %	P01120633		

(1) The higher value corresponds to 120% of the maximum nominal value.

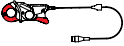
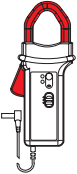

AC/DC CURRENT MEASUREMENT

Series	Model	Input						Output - Connections				Specific features					To order		
		Measuring range ⁽¹⁾						Current	Voltage	Lead + ø 4 mm safety connectors	Socket ø 4 mm	BNC connector (coaxial)	Transformation ratio (input/output)	Output protected against voltage swells	Automatic DC voltage	Measurement of power (slight phase shift)		Bandwidth (frequency in Hz)	Typical accuracy
		Very weak current	Weak current	Medium current	Strong current	AC	DC												
 Chapter D.1	E25		5 mA .. 2 A DC 5 mA .. 1.5 A AC 50 mA .. 80 A DC 50 mA .. 60 A AC				●	●				1 A / 1 V 1 A / 10 mV		●		DC .. 20 kHz	≤ 2 % ≤ 4 %	P01120025	
	E27		100 mA .. 10 A peak 500 mA .. 100 A peak				●	●			●	1 A / 100 mV 1 A / 10 mV		●		DC to 100 kHz	≤ 3 % ≤ 4 %	P01120027	
 Chapter D.2	MH60		0.01 A .. 140 A peak				●	●			●	10 mV/A		●		DC .. 1 MHz	≤ 1.5 %	P01120612	
 Chapter D.3	PAC15		0.5 A .. 400 A AC 0.5 A .. 600 A DC				●	●			●	1 A / 1 mV		●		DC to 30 kHz	≤ 2 %	P01120115	
	PAC16		0.5 A .. 40 A AC 0.5 A .. 60 A DC 0.5 A .. 400 A AC 0.5 A .. 600 A DC				●	●			●	1 A / 10 mV 1 A / 1 mV		●		DC to 30 kHz	≤ 1.5 % ≤ 2 %	P01120116	
	PAC17		0.5 A .. 60 A peak 0.5 A .. 600 A peak				●	●			●	1 A / 10 mV 1 A / 1 mV		●		DC to 30 kHz	≤ 1.5 % ≤ 2 %	P01120117	
 Chapter D.3	PAC25		0.5 A .. 1,000 A AC 0.5 A .. 1,400 A DC				●	●			●	1 A / 1 mV		●		DC to 30 kHz	≤ 4 %	P01120125	
	PAC26		0.5 A .. 100 A AC 0.5 A .. 150 A DC 0.5 A .. 1,000 A AC 0.5 A .. 1,400 A DC				●	●			●	1 A / 10 mV 1 A / 1 mV		●		DC to 30 kHz	≤ 1.5 % ≤ 4 %	P01120126	
	PAC27		0.5 A .. 150 A peak 0.5 A .. 1,400 A peak				●	●			●	1.5 V peak 1.4 V peak 1 A / 10 mV 1 A / 1 mV		●		DC to 30 kHz	≤ 1.5 % ≤ 4 %	P01120127	



(1) The higher value corresponds to 120% of the maximum nominal value.

Series	Model	Input						Output - Connections				Specific features					To order		
		Measuring range ⁽¹⁾						Current	Voltage	Lead + ø 4 mm safety connectors	Socket ø 4 mm	BNC connector (coaxial)	Transformation ratio (input/output)	Output protected against voltage swells	Automatic DC voltage	Measurement of power (slight phase shift)		Bandwidth (frequency in Hz)	Typical accuracy
		Very weak current	Weak current	Medium current	Strong current	AC	DC												

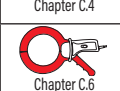
Leakage current measurement

 Chapter C.2	MN73	10 mA .. 24 A 100 mA .. 240 A						2 V AC 2 V AC				1 A / 1,000 mV 1 A / 10 mV				40 Hz .. 10 kHz	≤ 1% ≤ 2%	P01120421
 Chapter C.4	C173	1 mA .. 12 A 0.01 A .. 12 A 0.1 A .. 120 A 1 A .. 1,200 A						1 V AC				1 A / 1 V 10 A / 1 V 100 A / 1 V 1,000 A / 1 V				10 Hz .. 3 kHz	≤ 0.7% ≤ 0.3% ≤ 0.5% ≤ 0.2%	P01120309
 Chapter C.6	B102	500 µA .. 4 A 0.5 A .. 400 A						4 V AC 0.4 V AC				1 mA / 1 mV 1 A / 1 mV				10 Hz .. 1 kHz	≤ 0.5% ≤ 0.35%	P01120083

Measurement on oscilloscope

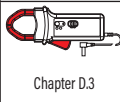
 Chapter C.2	MN60	0.1 A .. 60 A peak 0.5 A .. 600 A peak						6 V peak 6 V peak				1 A / 100 mV 1 A / 10 mV				40 Hz .. 40 kHz	≤ 2% ≤ 1.5%	P01120409
 Chapter C.3	Y7N	1 A .. 1,200 A peak						1.2 V peak				1 mA / 1 mV				5 Hz .. 10 kHz	≤ 2%	P01120075
 Chapter C.4	C160	0.1 A .. 30 A peak 1 A .. 300 A peak 1 A .. 2,000 A peak						3 V peak 3 V peak 2 V peak				10 A / 1 V 100 A / 1 V 1,000 A / 1 V				10 Hz .. 100 kHz	≤ 3% ≤ 2% ≤ 1%	P01120308
 Chapter C.5	D38N	1 A .. 90 A peak 1 A .. 900 A peak 1 A .. 9,000 A peak						0.9 V peak				1 A / 10 mV 1 A / 1 mV 1 A / 0.1 mV				30 Hz .. 50 kHz	≤ 2%	P01120057A
 Chapter D.1	E27	100 mA .. 10 A peak 500 mA .. 100 A peak						1 V peak 1 V peak				1 A / 100 mV 1 A / 10 mV				DC .. 100 kHz	≤ 3% ≤ 4%	P01120027
 Chapter D.2	MH60	0.01 A .. 140 A peak						1.4 V peak				10 mV/A				DC .. 1 MHz	≤ 1.5%	P01120612
 Chapter C.7	MA200 30-300/3 (17 cm / Ø 4.5 cm)	0.5 A .. 45 A peak 0.5 A .. 450 A peak						4.5 V peak				100 mV/A 10 mV/A				5 Hz .. 1 MHz	≤ 1% + 0.3 A	P01120570
	MA200 30-300/3 (25 cm / 7 cm)	0.5 A .. 45 A peak 0.5 A .. 450 A peak						4.5 V peak				100 mV/A 10 mV/A				5 Hz .. 1 MHz	≤ 1% + 0.3 A	P01120571
	MA200 3,000/3 (35 cm / Ø 10 cm)	5 A .. 4500 A peak						4.5 V peak				1 mV/A				5 Hz .. 1 MHz	≤ 1% + 0.3 A	P01120572
 Chapter D.3	PAC17	0.2 A .. 60 A peak 0.5 A .. 600 A peak						600 mV peak				1 A / 10 mV 1 A / 1 mV				DC to 30 kHz	≤ 1.5% ≤ 2%	P01120117
 Chapter D.3	PAC27	0.2 A .. 150 A peak 0.4 A .. 150 A DC						1.5 V peak				1 A / 10 mV				DC to 30 kHz	≤ 1.5%	P01120127
		0.5 A .. 1,400 A peak 0.5 A .. 1,400 A DC						1.4 V peak				1 A / 1 mV				DC to 30 kHz	≤ 4%	

Measurement on secondary winding of current transformers

 Chapter C.2	MN71	10 mA .. 12 A						1 V AC				1 A / 100 mV				40 Hz .. 10 kHz	≤ 1%	P01120420
--	------	---------------	--	--	--	--	--	--------	--	--	--	--------------	--	--	--	-----------------	------	-----------

(1) The higher value corresponds to 120% of the maximum nominal value.

NOTES

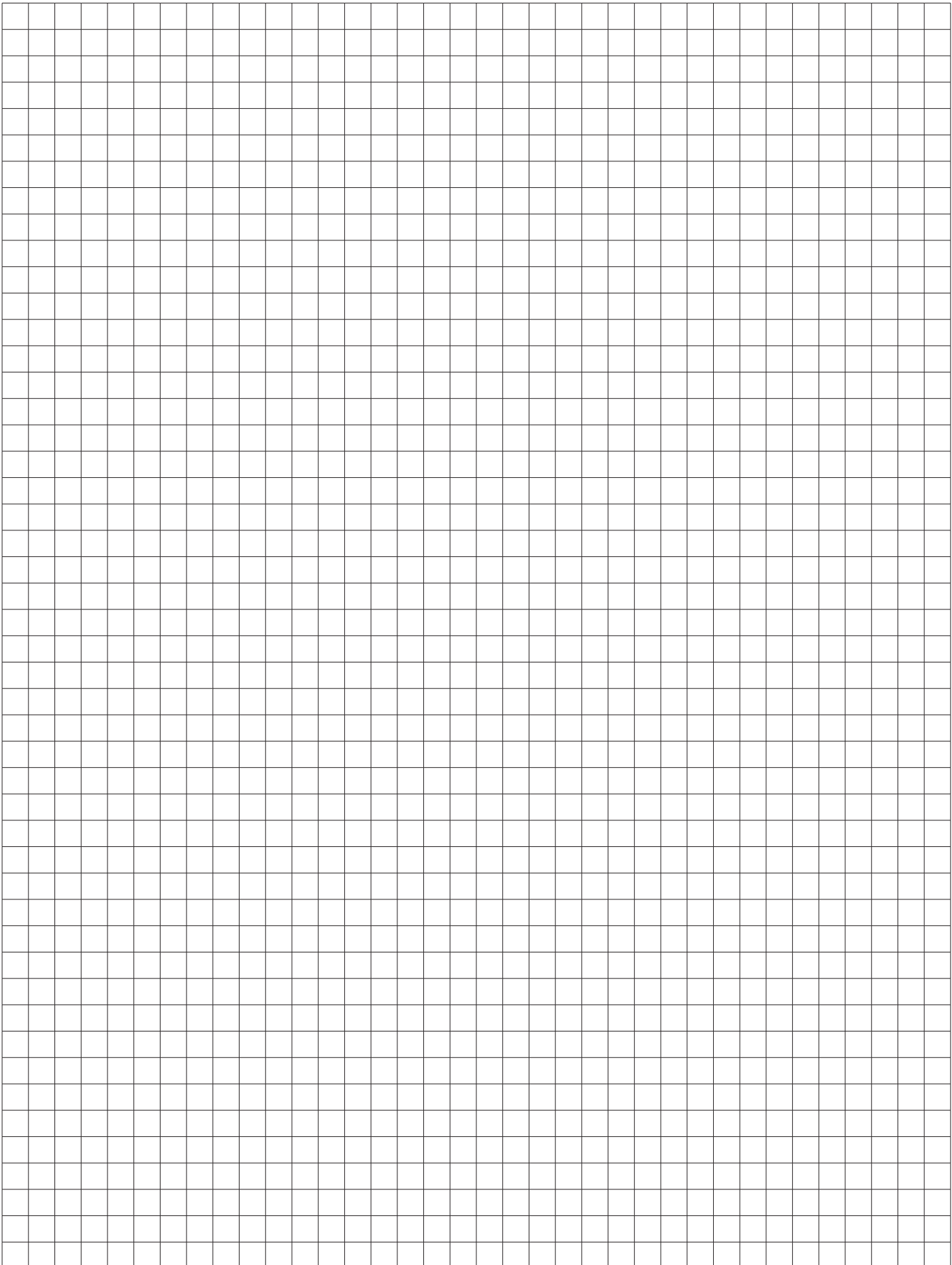

CURRENT CLAMPS FOR AC CURRENT



MINI series

Small, compact and particularly resistant, this range of miniature clamps is designed for measurements from a few milliamperes to 150 A AC. Their shape makes them very practical in confined spaces, such as circuit-breaker boards, control panels or control boxes. They are ideal for use with multimeters.

There are two types of MINI clamps.

The first type operates like a traditional current transformer and provides a current output (mA) which can be used with multimeters, loggers or instruments with current calibres.

The second provides a voltage output proportional to the current measured. This voltage output enables instruments with AC voltage calibres to display or store current values.

There is also a model with a DC voltage output.

The MINI clamps give True RMS results when used with a True RMS instrument.

MINI 100 series

Incorporating all the essentials which made the Miniclamps and the MINI10 Series so successful, the MINI 100 Series completes the range with a clamping diameter of 16 mm.

The models in the MINI 100 Series are equipped with a so-called "direct reading" input/output ratio and can measure currents up to 350 A.

CURRENT CLAMPS FOR AC CURRENT

MINI series

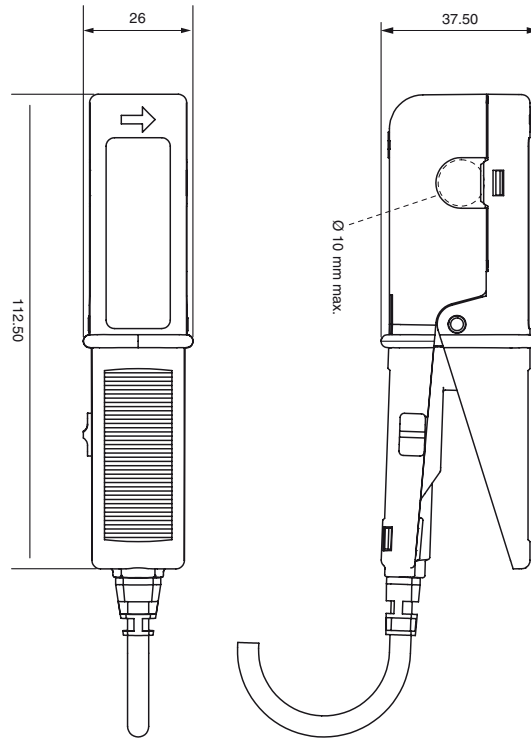

MINI 100 series

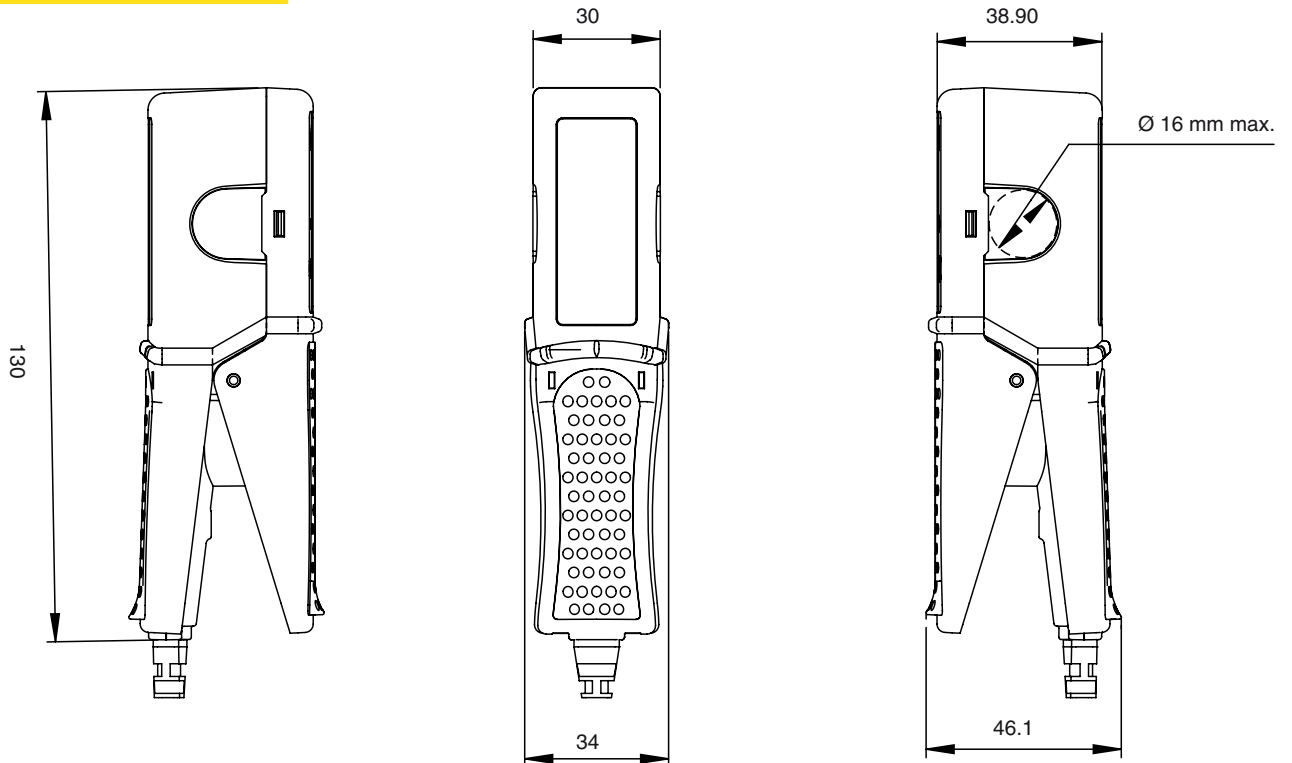

CURRENT CLAMPS FOR AC CURRENT

Model MINI 01

Calibre	150 A AC
Sensitivity	1 mA / A (1,000/1)

Description

Small and compact, the MINI 01 current clamp is the ideal complement for any multimeter to measure AC currents in low-power tertiary or industrial applications.

If there is a current in the conductor clamped, the MINI 01 clamp is protected against overvoltages during disconnection from the measurement instrument.



Main specifications ⁽¹⁾

Calibre	150 A
Measurement range	2 A .. 150 A
Accuracy of primary current in %	≤ 2.5 % + 0.15 A (1 Ω load) ≤ 3 % + 0.15 A (load 10 Ω)
Phase shift	not specified
Output signal	1 mA AC / A AC (1,000/1) (150 mA for 150 A)

- **Output:**
Double-insulated cable 1.5 m long, terminated by 2 insulated elbowed male banana connectors Ø 4 mm
- **Bandwidth:**
48 Hz .. 500 Hz
- **Clamping capacity:**
Cable Ø max 10 mm

Electrical specifications

- **Load impedance:**
≤ 10 Ω
- **Maximum currents:**
I < 150 A permanent from 48 Hz .. 500 Hz
- **Influence of temperature:**
≤ 0.2 % per 10 °K
- **Influence of adjacent conductor:**
≤ 2 mA / A at 50 Hz
- **Influence of conductor position in jaws:**
≤ 0.1 % at 50/60 Hz
- **Influence of frequency:**
≤ 2 % from 65 Hz at 500 Hz
- **Maximum output voltage (secondary open):**
30 V

Mechanical specifications

- **Operating temperature:**
-10°C to +50°C
- **Storage temperature:**
-40°C to +80°C
- **Relative humidity for operation:**
From 0 to 85 % RH with a linear decrease above 35 °C
- **Operating altitude:**
0 to 2,000 m
- **Casing protection rating (leakproofing):**
IP40 ⁽²⁾ (EN 60529 Ed.1992)
- **Drop test:**
1.5 m (IEC 68-2-32)
- **Shock resistance:**
100 g / 6 ms / half-period (IEC 68-2-27)
- **Vibration resistance ⁽³⁾:**
5-15 Hz (1.5 mm), 15-25 Hz (1 mm),
25-55 Hz (0.25 mm) (IEC 68-2-6)
- **Self-extinguishing capability:**
Casing UL94 V2
- **Dimensions:**
130 x 37 x 25 mm
- **Weight:**
approx. 180 g
- **Colour:**
Black casing

Safety specifications

- **Electrical safety:**
Instrument with double insulation or reinforced insulation between the primary, the secondary and the grippable part located under the guard as per EN 61010-1 Ed. 2:2001, EN 61010-2-031 Ed. 2002 & EN 61010-2-032 Ed. 2003
 - 600 V category III, pollution degree 2
 - 300 V category IV, pollution degree 2
- **Electromagnetic compatibility:**
CE-certified equipment compliant with standard EN 61326-1 (Ed.97) + A1 (Ed.98) + A2 (Ed.01)
 - Emission: stipulations for class B equipment (domestic use).
 - Immunity: stipulations for equipment used intermittently on industrial sites.

(1) Conditions of reference: 23 °C ± 3 °K, 20 °C to 75% RH, sinusoidal signal with frequency of 48 Hz to 65 Hz, distortion factor < 1 % with no DC component, external DC magnetic field < 40 A/m, no external AC magnetic field, no external conductor with circulating current, conductor centred for measurement, measurement instrument load impedance ≤ 10 Ω.

(2) With clamp closed.

(3) Vibrations expressed in mm peak, scanning of 1 octave/minute for 10 minutes on 3 axes.

To order	Reference
AC current clamp model MINI 01 with operating manual	P01105101Z

CURRENT CLAMPS FOR AC CURRENT

Model MINI 02

Calibre	100 A AC
Sensitivity	1 mA / A (1,000/1)

Description

The MINI 02 current clamp, whose jaws are equipped with a high-performance magnetic material and a double coil, offers excellent linearity and improved performance.

Small and compact, it is ideal for measuring AC currents in low-power tertiary or industrial applications. If a current is present in the conductor being clamped, the MINI 02 clamp is protected against voltage surges when it is disconnected from the measurement instrument.



Main specifications ⁽¹⁾

Calibre	100 A
Measurement range	50 mA .. 100 A (load 1 Ω) 50 mA .. 90 A (load 10 Ω)
Accuracy of primary current in %	≤ 1% + 0.02 A (load 1 Ω) ≤ 1.5% + 0.01 A (load 10 Ω)
Phase shift	≤ 3° (load 1 Ω) ≤ 6° (load 10 Ω)
Output signal	1 mA AC / A AC (1,000/1) (100 mA for 100 A)

- **Output:**
Double-insulated cable 1.5 m long, terminated by 2 insulated elbowed male banana connectors Ø 4 mm
- **Bandwidth:**
48 Hz .. 10,000 Hz
- **Clamping capacity:**
Cable Ø max 10 mm

Electrical specifications

- **Load impedance:**
≤ 100 Ω
- **Maximum currents:**
I < 100 A permanent from 48 Hz .. 10,000 Hz
- **Influence of load impedance:**
See curves
- **Influence of temperature:**
≤ 0.2% per 10 °K
- **Influence of adjacent conductor:**
≤ 2 mA / A at 50 Hz
- **Influence of conductor position in jaws:**
≤ 0.1% at 50/60 Hz
- **Influence of frequency:**
≤ 2% from 65 Hz at 10 kHz
- **Maximum output voltage (secondary open):**
≤ 30 V

Mechanical specifications

- **Operating temperature:**
-10°C to +50°C
- **Storage temperature:**
-40°C to +80°C
- **Relative humidity for operation:**
From 0 to 85% RH with a linear decrease above 35 °C
- **Operating altitude:**
0 to 2,000 m
- **Casing protection rating (leakproofing):**
IP40 ⁽²⁾ (EN 60529 Ed.1992)
- **Drop test:**
1.5 m (IEC 68-2-32)
- **Shock resistance:**
100 g / 6 ms / half-period (IEC 68-2-27)
- **Vibration resistance ⁽³⁾:**
5-15 Hz (1.5 mm), 15-25 Hz (1 mm),
25-55 Hz (0.25 mm) (IEC 68-2-6)
- **Self-extinguishing capability:**
Casing UL94 V2
- **Dimensions:**
130 x 37 x 25 mm
- **Weight:**
approx. 180 g
- **Colour:**
Black casing

Safety specifications

- **Electrical safety:**
Instrument with double insulation or reinforced insulation between the primary, the secondary and the grippable part located under the guard as per EN 61010-1 Ed. 2:2001, EN 61010-2-031 Ed. 2002 & EN 61010-2-032 Ed. 2003
- 600 V category III, pollution degree 2
- 300 V category IV, pollution degree 2
- **Electromagnetic compatibility:**
CE-certified equipment compliant with standard EN 61326-1 (Ed.97)
+ A1 (Ed.98) + A2 (Ed.01)
- Emission: stipulations for class B equipment (domestic use).
- Immunity: stipulations for equipment used intermittently on industrial sites.

CURRENT CLAMPS FOR AC CURRENT

Model MINI 02

Curves at 50 Hz

Typical linearity error for loads of 1, 10, 30 and 100 Ω

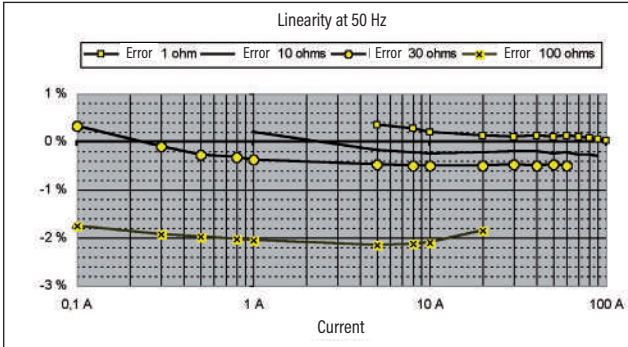

Typical phase shift for loads of 1, 10, 30 and 100 Ω

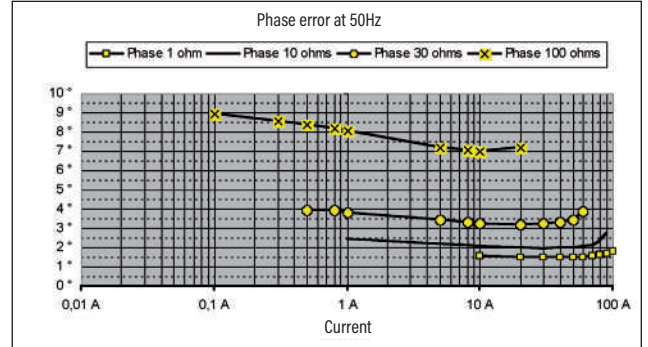

Frequency response at 10 A

Typical linearity error for loads of 1, 10, 30 and 100 Ω

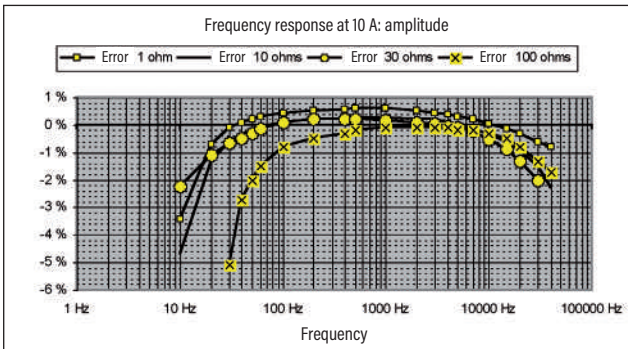

Typical phase shift for loads of 1, 10, 30 and 100 Ω

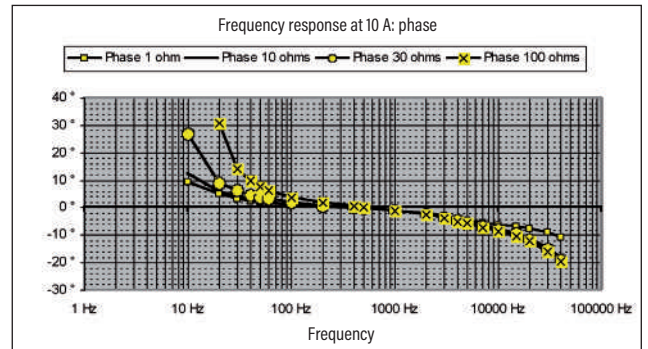

(1) Conditions of reference: 23 °C ± 3 °K, 20 °C to 75% RH, sinusoidal signal with frequency of 48 Hz to 10 kHz, distortion factor < 1 % with no DC component, external DC magnetic field < 40 A/m, no external AC magnetic field, no external conductor with circulating current, conductor centred for measurement, measurement instrument load impedance ≤ 10 Ω.

(2) With clamp closed.

(3) Vibrations expressed in mm peak, scanning of 1 octave/minute for 10 minutes on 3 axes.

To order	Reference
AC current clamp model MINI 02 with operating manual	P01105102Z

CURRENT CLAMPS FOR AC CURRENT

Model MINI 03

Calibre	100 A AC
Sensitivity	1 mV / A

Description

Small and compact, the MINI 03 current clamp is the ideal complement for any multimeter to measure AC currents in low-power tertiary or industrial applications.

When used with an AC voltmeter, it allows you to directly read the current measured on the voltmeter.

Main specifications ⁽¹⁾

Calibre	100 A
Measurement range	1 A .. 100 A
Accuracy of primary current in %	≤ 2 % + 50 mA
Phase shift	not specified
Output signal	1 mV AC / A AC (100 mV for 100 A)



- **Output:**
Double-insulated cable 1.5 m long, terminated by 2 insulated elbowed male banana connectors Ø 4 mm
- **Bandwidth:**
48 Hz .. 500 Hz
- **Clamping capacity:**
Cable Ø max 10 mm

Electrical specifications

- **Maximum currents:**
I < 150 A permanent from 48 Hz .. 500 Hz
- **Influence of temperature:**
≤ 0.2% per 10 °K
- **Influence of adjacent conductor:**
≤ 2 mA / A at 50 Hz
- **Influence of conductor position in jaws:**
≤ 0.1% at 50/60 Hz
- **Influence of frequency:**
≤ 1% from 65 Hz at 500 Hz

Mechanical specifications

- **Operating temperature:**
-10°C to +50°C
- **Storage temperature:**
-40°C to +80°C
- **Relative humidity for operation:**
0 to 85% RH with a linear decrease above 35°C
- **Operating altitude:**
0 to 2,000 m
- **Casing protection rating (leakproofing):**
IP40 ⁽²⁾ (EN 60529 Ed. 1992)
- **Drop test:**
1.5 m (IEC 68-2-32)
- **Shock resistance:**
100 g / 6 ms / half-period (IEC 68-2-27)
- **Vibration resistance ⁽³⁾:**
5-15 Hz (1.5 mm), 15-25 Hz (1 mm), 25-55 Hz (0.25 mm) (IEC 68-2-6)
- **Self-extinguishing capability:**
Casing UL94 V2
- **Dimensions:**
130 x 37 x 25 mm
- **Weight:**
approx. 180 g
- **Colour:**
Black casing

Safety specifications

- **Electrical safety:**
Instrument with double insulation or reinforced insulation between the primary, the secondary and the grippable part located under the guard as per EN 61010-1 Ed. 2:2001, EN 61010-2-031 Ed. 2002 & EN 61010-2-032 Ed. 2003
- 600 V category III, pollution degree 2
- 300 V category IV, pollution degree 2
- **Electromagnetic compatibility:**
CE-certified equipment compliant with standard EN 61326-1 (Ed. 97) + A1 (Ed. 98) + A2 (Ed. 01)
- Emission: stipulations for class B equipment (domestic use).
- Immunity: stipulations for equipment used intermittently on industrial sites.

(1) Conditions of reference: 23 °C ± 3 °K, 20 °C to 75% RH, sinusoidal signal with frequency of 48 Hz to 65 Hz, distortion factor < 1% with no DC component, external DC magnetic field < 40 A/m, no external AC magnetic field, no external conductor with circulating current, conductor centred for measurement, measurement instrument load impedance ≥ 10 kΩ

(2) With clamp closed.

(3) Vibrations expressed in mm peak, scanning of 1 octave/minute for 10 minutes on 3 axes.

To order	Reference
AC current clamp model MINI 03 with operating manual	P01105103Z

CURRENT CLAMPS FOR AC CURRENT

Model MINI 05

Calibre	10 A AC	100 A AC
Sensitivity	1 mV / mA	1 mV / A

Description

Small and compact, the MINI 05 current clamp is the ideal complement for any multimeter to measure AC currents in low-power tertiary or industrial applications.

With its 2 calibres, it offers excellent resolution for measuring AC currents from 5 mA to 100 A.

Main specifications ⁽¹⁾

Calibre	10 A	100 A
Measurement range	5 mA .. 10 A	1 A .. 100 A
Accuracy of primary current in %	$\leq 3\% + 0.15 \text{ mA}$	$\leq 2\% + 50 \text{ mA}$
Phase shift	not specified	
Output signal	1 mV AC / mA AC (10 V for 10 A)	1 mV AC / A AC (100 mV for 100 A)



- **Output:**
Double-insulated cable 1.5 m long, terminated by 2 insulated elbowed male banana connectors \varnothing 4 mm
- **Bandwidth:**
48 Hz .. 500 Hz
- **Clamping capacity:**
Cable \varnothing max 10 mm

Electrical specifications

- **Maximum currents:**
- 100 A calibre: $I < 150 \text{ A}$ permanent from 48 Hz .. 500 Hz
- 10 A calibre: $I < 15 \text{ A}$ permanent from 48 Hz .. 500 Hz
- **Influence of temperature:**
 $\leq 0.2\%$ per 10°K
- **Influence of adjacent conductor:**
 $\leq 2 \text{ mA / A}$ at 50 Hz
- **Influence of conductor position in jaws:**
 $\leq 0.1\%$ at 50/60 Hz
- **Influence of frequency:**
- 100 A calibre: $\leq 1\%$ from 65 Hz at 500 Hz
- 10 A calibre: $\leq 3\%$ from 65 Hz at 500 Hz

Mechanical specifications

- **Operating temperature:**
 -10°C to $+50^\circ\text{C}$
- **Storage temperature:**
 -40°C to $+80^\circ\text{C}$
- **Relative humidity for operation:**
0 to 85% RH with a linear decrease above 35°C
- **Operating altitude:**
0 to 2,000 m
- **Casing protection rating (leakproofing):**
IP40 ⁽²⁾ (EN 60529 Ed.1992)
- **Drop test:**
1.5 m (IEC 68-2-32)
- **Shock resistance:**
100 g / 6 ms / half-period (IEC 68-2-27)
- **Vibration resistance ⁽³⁾:**
5-15 Hz (1.5 mm), 15-25 Hz (1 mm),
25-55 Hz (0.25 mm) (IEC 68-2-6)
- **Self-extinguishing capability:**
Casing UL94 V2
- **Dimensions:**
130 x 37 x 25 mm
- **Weight:**
approx. 180 g
- **Colour:**
Black casing

Safety specifications

- **Electrical safety:**
Instrument with double insulation or reinforced insulation between the primary, the secondary and the grippable part located under the guard as per EN 61010-1 Ed. 2:2001, EN 61010-2-031 Ed. 2002 & EN 61010-2-032 Ed. 2003
- 600 V category III, pollution degree 2
- 300 V category IV, pollution degree 2
- **Electromagnetic compatibility:**
CE-certified equipment compliant with standard EN 61326-1 (Ed.97) + A1 (Ed.98) + A2 (Ed.01)
- Emission: stipulations for class B equipment (domestic use).
- Immunity: stipulations for equipment used intermittently on industrial sites.

(1) Conditions of reference: $23^\circ\text{C} \pm 3^\circ\text{K}$, 20°C to 75% RH, sinusoidal signal with frequency of 48 Hz to 65 Hz, distortion factor $< 1\%$ with no DC component, external DC magnetic field $< 40 \text{ A/m}$, no external AC magnetic field, no external conductor with circulating current, conductor centred for measurement, measurement instrument load impedance $\geq 1 \text{ M}\Omega$ (10 A calibre) & $\geq 10 \text{ k}\Omega$ (100 A calibre).

(2) With clamp closed.

(3) Vibrations expressed in mm peak, scanning of 1 octave/minute for 10 minutes on 3 axes.

To order	Reference
AC current clamp model MINI 05 with operating manual	P01105105Z

CURRENT CLAMPS FOR AC CURRENT

Model MINI 09

Calibre	150 AAC
Sensitivity	100 mV DC / A AC

Description

Small and compact, the MINI 09 current clamp is the ideal complement for any multimeter to measure AC currents in low-power tertiary or industrial applications.

Its DC voltage output helps to overcome the low sensitivity of certain AC measurement instruments.



Main specifications ⁽¹⁾

Calibre	150 A			
	Measurement range	1 A .. 5 A	5 A .. 15 A	15 A .. 40 A
Accuracy of primary current in %	≤ 10% + 0.6 A	≤ 6% + 0.6 A	≤ 3% + 0.6 A	≤ 4%
Phase shift	not specified			
Output signal	100 mV DC / A AC (15 V DC for 150 A)			

- **Output:**
Double-insulated cable 1.5 m long, terminated by 2 insulated elbowed male banana connectors Ø 4 mm
- **Bandwidth:**
48 Hz .. 500 Hz
- **Clamping capacity:**
Cable Ø max 10 mm

Electrical specifications

- **Maximum currents:**
I < 150 A permanent from 65 Hz .. 500 Hz
- **Influence of temperature:**
≤ 0.2% per 10 °K
- **Influence of adjacent conductor:**
≤ 2 mA / A at 50 Hz
- **Influence of conductor position in jaws:**
≤ 0.1% at 50/60 Hz
- **Influence of frequency:**
≤ 3% from 65 Hz at 500 Hz

Mechanical specifications

- **Operating temperature:**
-10°C to +50°C
- **Storage temperature:**
-40°C to +80°C
- **Relative humidity for operation:**
0 to 85% RH with a linear decrease above 35°C
- **Operating altitude:**
0 to 2,000 m
- **Casing protection rating (leakproofing):**
IP40 ⁽²⁾ (EN 60529 Ed. 1992)
- **Drop test:**
1.5 m (IEC 68-2-32)
- **Shock resistance:**
100 g / 6 ms / half-period (IEC 68-2-27)
- **Vibration resistance ⁽³⁾:**
5-15 Hz (1.5 mm), 15-25 Hz (1 mm), 25-55 Hz (0.25 mm) (IEC 68-2-6)
- **Self-extinguishing capability:**
Casing UL94 V2
- **Dimensions:**
130 x 37 x 25 mm
- **Weight:**
approx. 180 g
- **Colour:**
Black casing

Safety specifications

- **Electrical safety:**
Instrument with double insulation or reinforced insulation between the primary, the secondary and the grippable part located under the guard as per EN 61010-1 Ed. 2:2001, EN 61010-2-031 Ed. 2002 & EN 61010-2-032 Ed. 2003
- 600 V category III, pollution degree 2
- 300 V category IV, pollution degree 2
- **Electromagnetic compatibility:**
CE-certified equipment compliant with standard EN 61326-1 (Ed. 97) + A1 (Ed. 98) + A2 (Ed. 01)
- Emission: stipulations for class B equipment (domestic use).
- Immunity: stipulations for equipment used intermittently on industrial sites.

(1) Conditions of reference: 23 °C ± 3 °K, 20 °C to 75% RH, sinusoidal signal with frequency of 48 Hz to 65 Hz, distortion factor < 1% with no DC component, external DC magnetic field < 40 A/m, no external AC magnetic field, no external conductor with circulating current, conductor centred for measurement, measurement instrument load impedance ≥ to 50 kΩ

(2) With clamp closed.

(3) Vibrations expressed in mm peak, scanning of 1 octave/minute for 10 minutes on 3 axes.

To order	Reference
AC current clamp model MINI 09 with operating manual	P01105109Z

CURRENT CLAMPS FOR AC CURRENT

Model MINI 102

Calibre	200 A AC
Sensitivity	1 mA / A (1,000/1)

Description

The MINI 102 current clamp, whose jaws are equipped with a high-performance magnetic material and a double coil, offers excellent linearity and improved performance.

If a current is present in the conductor being clamped, the MINI 102 clamp is protected against voltage surges when it is disconnected from the measurement instrument.

Main specifications ⁽¹⁾

Calibre	200 A
Measurement range	50 mA .. 200 A (load 1 Ω) 50 mA .. 200 A (load 10 Ω) 50 mA .. 20 A (load 100 Ω)
Accuracy in %	≤ 1.5 % + 0.02 A (load 1 Ω) ≤ 1.5 % + 0.01 A (load 10 Ω) ≤ 4 % + 0.01 A (load 100 Ω)
Phase shift	≤ 3° (load 1 Ω) ≤ 6° (load 10 Ω) ≤ 12° (load 10 Ω)
Output signal	1 mA AC / A AC (1,000/1) (200 mA for 200 A)



- **Output:**
Double-insulated cable 1.5 m long, terminated by 2 insulated elbowed male banana connectors Ø 4 mm
- **Bandwidth:**
48 Hz .. 10,000 Hz
- **Clamping capacity:**
Cable Ø max 16 mm

Electrical specifications

- **Load impedance:**
≤ 100 Ω
 - **Influence of load impedance:**
See curves
 - **Maximum currents:**
350 A permanent at a frequency ≤ 1 kHz.
200 A permanent at a frequency ≤ 8 kHz
- (limitation proportional to the reciprocal of the frequency beyond that)
- **Influence of temperature:**
≤ 0.2 % per 10 °K
 - **Influence of adjacent conductor:**
≤ 2 mA / A at 50 Hz
 - **Influence of conductor position in jaws:**
≤ 0.08 % at 50/60 Hz
 - **Influence of frequency:**
typically ≤ 1%
 - **Maximum output voltage (secondary open):**
≤ 30 V

Mechanical specifications

- **Operating temperature:**
-10°C to +50°C
- **Storage temperature:**
-40°C to +80°C
- **Relative humidity for operation:**
0 to 85 % RH with a linear decrease above 35 °C
- **Operating altitude:**
0 to 2,000 m
- **Casing protection rating (leakproofing):**
IP20 ⁽²⁾ (EN 60529 Ed. 2001)
- **Drop test:**
1 m (IEC 68-2-32)
- **Dimensions:**
130.4 x 46 x 34 mm
- **Weight:**
approx. 250 g
- **Colour:**
Black casing

Mechanical specifications

- **Electrical safety:**
Instrument with double insulation or reinforced insulation between the primary, the secondary and the grippable part located under the guard as per EN 61010-1 Ed. 2:2001, EN 61010-2-031 Ed. 2002 & EN 61010-2-032 Ed. 2003
 - 600 V category III, pollution degree 2
 - 300 V category IV, pollution degree 2
- **Electromagnetic compatibility:**
CE-certified equipment compliant with standard EN 61326-1: 2006
 - Emission: stipulations for class B equipment (domestic use).
 - Immunity: stipulations for equipment used intermittently on industrial sites.

CURRENT CLAMPS FOR AC CURRENT

Model MINI 102

Curves at 50 Hz

Typical linearity error for loads of 1, 10 and 100 Ω

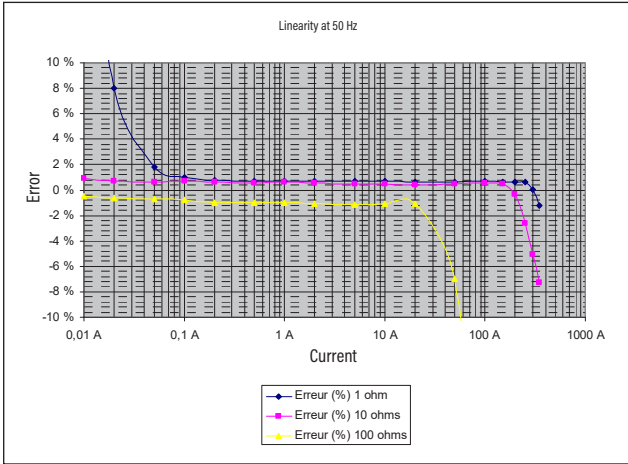

Typical phase shift for loads of 1, 10, 30 and 100 Ω

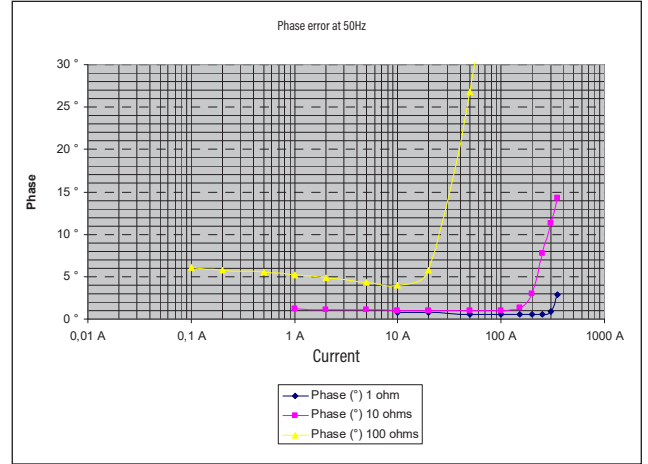

Frequency response at 10 A

Typical linearity error for loads of 1, 10 and 100 Ω

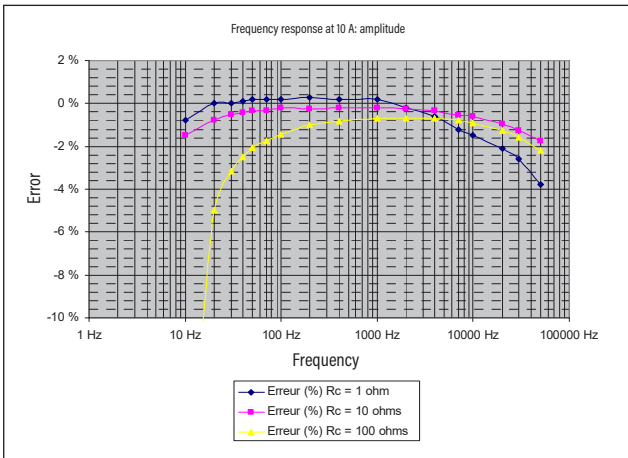

Typical phase shift for loads of 1, 10 and 100 Ω

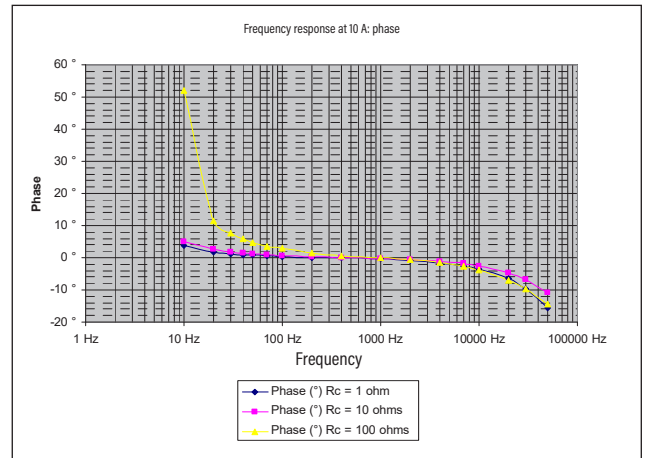

(1) Conditions of reference: 23 °C ± 3 °K, 20 °C to 75% RH, sinusoidal signal with frequency of 48 Hz to 10 kHz, distortion factor < 1 % with no DC component, external DC magnetic field < 40 A/m, no external AC magnetic field, no external conductor with circulating current, conductor centred for measurement, measurement instrument load impedance ≤ 10 Ω.

(2) With clamp closed.

To order	Reference
AC current clamp model MINI 102 with operating manual	P01106102

CURRENT CLAMPS FOR AC CURRENT

Model MINI 103

Calibre	200 A AC
Sensitivity	1 mV / A

Description

The MINI 103 current clamp is the ideal companion for any multimeter to measure AC currents in tertiary or industrial applications.

When used with an AC voltmeter, it allows you to directly read the current measured on the voltmeter.

Main specifications ⁽¹⁾

Calibre	200 A
Measurement range	0.1 A .. 200 A AC
Accuracy in %	≤ 1.5 % + 0.02 A
Phase shift	≤ 3°
Output signal	1 mVAC / AAC (200 mV for 200 A)



- **Output:**
Double-insulated cable 1.5 m long, terminated by 2 insulated elbowed male banana connectors Ø 4 mm
- **Bandwidth:**
48 Hz .. 10,000 Hz
- **Clamping capacity:**
Cable Ø max 16 mm

Electrical specifications

- **Load impedance:**
≥ 10 kΩ
- **Influence of load impedance:**
See curves
- **Maximum currents:**
350 A permanent at a frequency ≤ 1 kHz.
200 A permanent at a frequency ≤ 8 kHz

(limitation proportional to the reciprocal of the frequency beyond that)
- **Influence of temperature:**
≤ 0.2 % per 10 °K
- **Influence of adjacent conductor:**
≤ 2 mA / A at 50 Hz
- **Influence of conductor position in jaws:**
≤ 0.08 % at 50/60 Hz
- **Influence of frequency:**
typically ≤ 1%

Mechanical specifications

- **Operating temperature:**
-10°C to +50°C
- **Storage temperature:**
-40°C to +80°C
- **Relative humidity for operation:**
0 to 85 % RH with a linear decrease above 35°C
- **Operating altitude:**
0 to 2,000 m
- **Casing protection rating (leakproofing):**
IP20 ⁽²⁾ (EN 60529 Ed. 2001)
- **Drop test:**
1 m (IEC 68-2-32)
- **Dimensions:**
130.4 x 46 x 34 mm
- **Weight:**
approx. 250 g
- **Colour:**
Black casing

Safety specifications

- **Electrical safety:**
Instrument with double insulation or reinforced insulation between the primary, the secondary and the grippable part located under the guard as per EN 61010-1 Ed. 2:2001, EN 61010-2-031 Ed. 2002 & EN 61010-2-032 Ed. 2003
- 600 V category III, pollution degree 2
- 300 V category IV, pollution degree 2
- **Electromagnetic compatibility:**
CE-certified equipment compliant with standard EN 61326-1: 2006
- Emission: stipulations for class B equipment (domestic use).
- Immunity: stipulations for equipment used intermittently on industrial sites.

CURRENT CLAMPS FOR AC CURRENT

Model MINI 103

Curves at 50 Hz

Typical linearity error

Typical phase shift

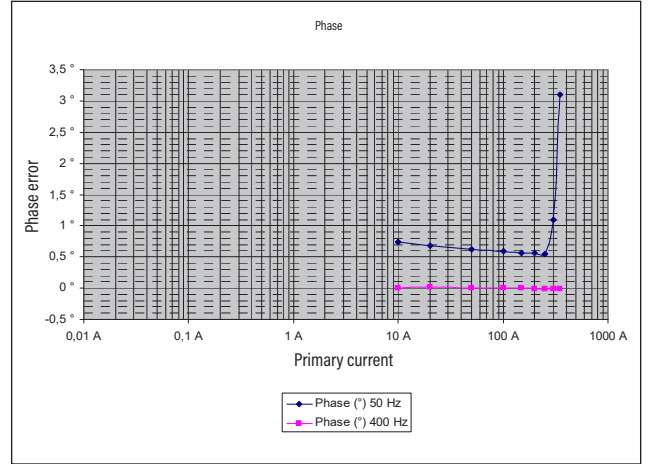
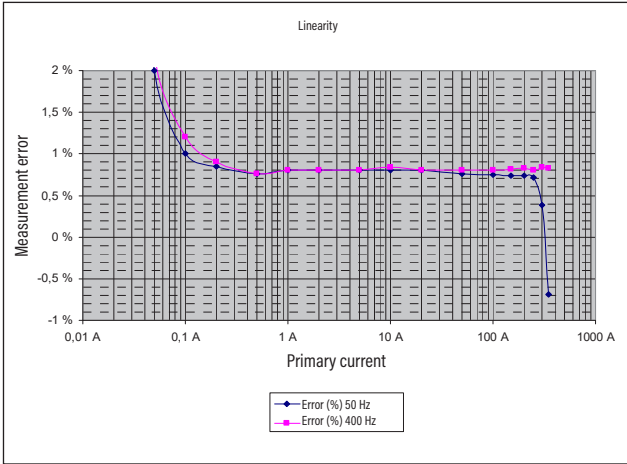

Frequency response

Typical linearity error

Typical phase shift

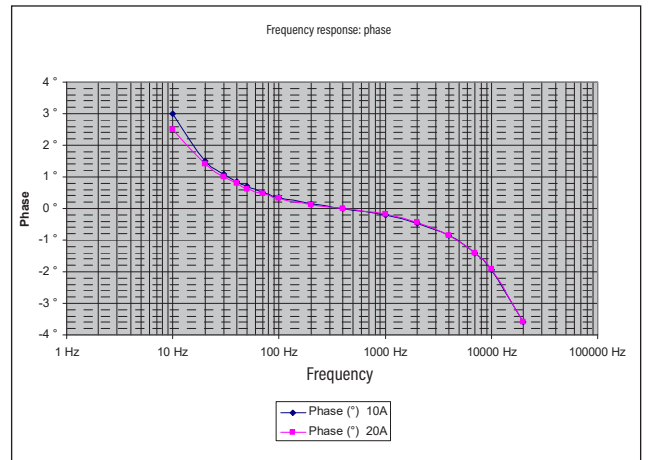
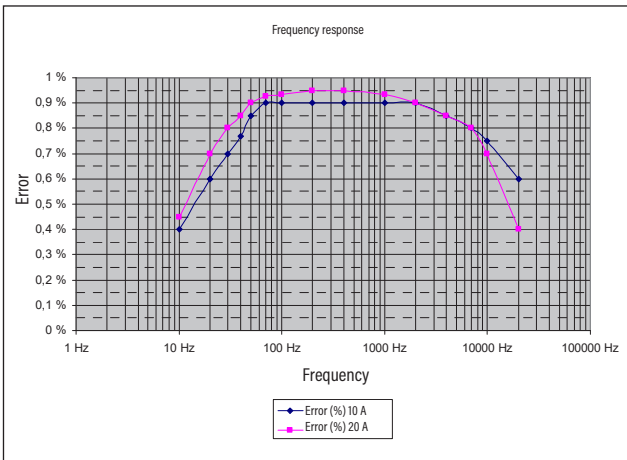

- (1) Conditions of reference: 23 °C ± 3 °K, 20 °C to 75% RH, sinusoidal signal with frequency of 48 Hz to 65 Hz, distortion factor < 1 % with no DC component, external DC magnetic field < 40 A/m, no external AC magnetic field, no external conductor with circulating current, conductor centred for measurement, measurement instrument load impedance ≥ to 10 kΩ
- (2) With clamp closed.

To order	Reference
AC current clamp model MINI 103 with operating manual	P01106103

CURRENT CLAMPS FOR AC CURRENT



MN series

These ergonomic mini-clamps are designed to make light work of measuring low and medium currents from 0.01 A to 240 A AC.

The shape of the jaws makes 'hooking' onto cables easy, even in areas of restrictive access. The jaws can grip conductors up to \varnothing 20 mm in diameter.

Depending on the particular model, they have one or two calibres. The output is via either jack sockets or a lead with 4 mm \varnothing plugs, hence these clamps are compatible with all multimeters and testers on the market.

Two types are available:

- The first kind operates as a current transformer (ratio 1,000/1) and gives a current output (mA) for use with any tester with current calibres.

- The second type gives a voltage output (DC or AC depending on the model) proportional to the measured current (1, 10, 100 or 1,000 mV / A). This voltage output means that, even with testers without any current calibres, it is possible to measure currents by means of the DC or AC voltage calibres.

There are specific models in the MN series that have been designed with particular applications in mind such as measurement on current transformer outputs, on oscilloscopes and even of leakage currents.

CURRENT CLAMPS FOR AC CURRENT

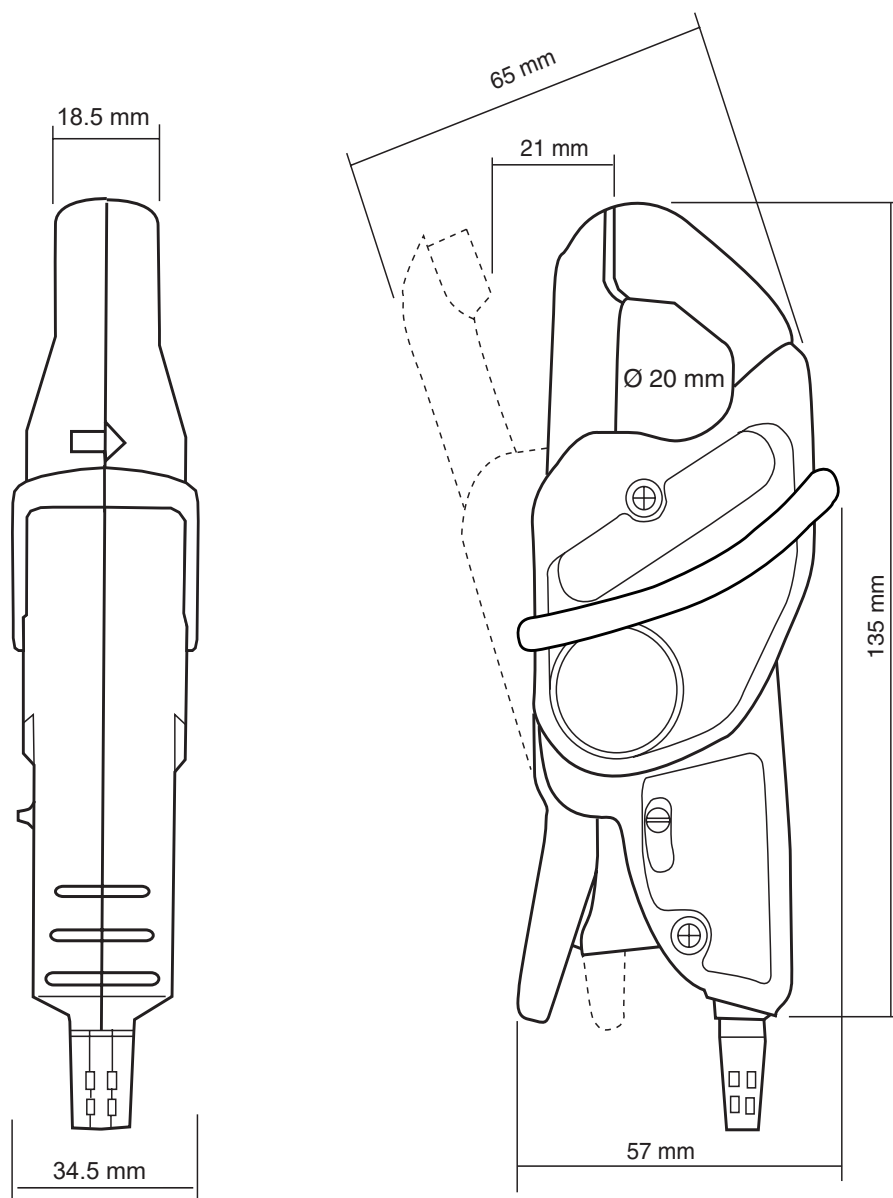

CURRENT CLAMPS FOR AC CURRENT

Models MN08 and MN09

Current	200 A AC
Ratio	1,000/1
Output	1 mA / A



Electrical specifications

- **Current range:**
0.5 A AC .. 240 A AC
- **Turns Ratio:**
1,000/1
- **Accuracy and phase shift ⁽¹⁾:**

Primary current:	0.5 A .. 10 A	10 A .. 40 A	40 A .. 100 A	100 A .. 240 A
Accuracy in % of output signal	≤ 3% + 0.5 mA	≤ 2.5% + 0.5 mA	≤ 2% + 0.5 mA	≤ 1% + 0.5 mA
Phase shift	not specified	≤ 5°	≤ 3°	≤ 2.5°

- **Output signal:**
1 mA AC / A AC (240 mA for 240 A)
- **Bandwidth:**
40 Hz .. 10 kHz
- **Crest factor:**
3 for a current of 200 A_{RMS}
- **Maximum currents:**
200 A continuous for a frequency ≤ 3 kHz (limitation proportional to the inverse of one third of frequency beyond)
- **Load impedance:**
≤ 10 Ω
- **Operating voltage:**
600 V_{RMS}
- **Common mode voltage:**
600 V category III and pollution degree 2
- **Influence of adjacent conductor:**
≤ 15 mA / A at 50 Hz
- **Influence of conductor position in jaws:**
≤ 0.5% of output signal at 50/60 Hz
- **Load influence:**
From 0.2 ... 10 Ω
< 0.5 % on measurement
< 0.5 ° on phase
- **Influence of frequency ⁽²⁾:**
< 3 % of output signal from 40 Hz .. 1kHz
< 12 % of output signal from 1 kHz .. 10 kHz
- **Influence of crest factor:**
< 4 % of output signal for a crest factor of 3 and current 200 A_{RMS}

Mechanical specifications

- **Operating temperature:**
-10°C to +55°C
- **Storage temperature:**
-40°C to +70°C
- **Influence of temperature:**
≤ 0.15 % of output signal per 10 °K
- **Relative humidity for operation:**
0 to 85 % RH with a linear decrease above 35 °C
- **Influence of relative humidity:**
< 0.2 % of output signal from 10 % to 85 % RH
- **Operating altitude:**
0 to 2,000 m
- **Max. jaw opening:**
20 mm
- **Clamping capacity:**
Cable: Ø max 20 mm
Busbar: 1 busbar of 20 x 5mm
- **Casing protection rating:**
IP40 (IEC 529)
- **Drop test:**
1 m (IEC 68-2-32)
- **Shock resistance:**
100 g (IEC 68-2-27)
- **Vibration resistance:**
10 / 55/10 Hz, 0.15 mm (IEC 68-2-6)

- **Self-extinguishing capability:**
Casing: UL94 V2
Jaws: UL94 V0
- **Dimensions:**
135 x 51 x 30 mm
- **Weight:**
approx. 180 g
- **Colour:**
Dark grey case with red jaws
- **Output:**
MN08: Safety sockets (4mm)
MN09: Two-wire cable with reinforced insulation or double insulation, length 1.5 m, terminated by 2 insulated elbowed male banana plugs (4 mm)

Safety specifications

- **Electrical safety:**
Instrument with double insulation or reinforced insulation between the primary, the secondary and the grippable part located under the guard as per IEC 1010-1 & IEC 1010-2-032.
- 600 V category III, pollution degree 2
- 300 V category IV, pollution degree 2
- **Electromagnetic compatibility (EMC):** :
EN 50081-1: class B
EN 50082-2:
- Electrostatic discharge: IEC 1000-4-2
- Radiated field: IEC 1000-4-3
- Fast transients: IEC 1000-4-4
- Magnetic field at 50/60Hz: IEC 1000-4-8

(1) Conditions of reference: 23 °C ± 3 °K, 20 to 70 % RH, sinusoidal signal with frequency of 48 Hz to 65 Hz, external magnetic field < 40 A/m, no DC components, no external conductor with circulating current, conductor centred for measurement, 1 Ω load.

(2) Out of reference domain.

To order	Reference
AC current clamp model MN08 with operating manual	P01120401
AC current clamp model MN09 with operating manual	P01120402

CURRENT CLAMPS FOR AC CURRENT

Models MN10 and MN11

Current	200 A AC
Ratio	1,000/1
Output	1 mA / A

Description

An electronic voltage-limiting system protects output of clamp when operating, if the secondary circuit is opened.

Electrical specifications

- Current range:**
0.5 A AC .. 240 A AC
- Turns Ratio:**
1,000/1
- Output signal:**
1 mA AC / A AC (240 mA for 240 A)
- Accuracy and phase shift ⁽¹⁾:**

Primary current:	0.5 A .. 10 A	10 A .. 40 A	40 A .. 100 A	100 A .. 150 A	150 A .. 200 A	200 A .. 240 A
Accuracy in % of output signal	≤ 3% + 0.5 mA	≤ 2.5% + 0.5 mA	≤ 2% + 0.5 mA	≤ 1% + 0.5 mA	≤ 2% + 0.5 mA	≤ 3% + 0.5 mA
Phase shift	not specified	≤ 5°	≤ 3°	≤ 2.5°	≤ 2.5°	≤ 2.5°

- Bandwidth:**
40 Hz .. 10 kHz
- Crest factor:**
3 for a current of 200 A_{RMS}
- Maximum currents:**
200 A continuous for a frequency ≤ 3 kHz (limitation proportional to the inverse of one third of frequency beyond)
- Load impedance:**
≤ 10 Ω
- Operating voltage:**
600 V_{RMS}
- Maximum output voltage (secondary open):**
Limited to 8 V peak max.
- Operating voltage:**
600 V_{RMS}
- Common mode voltage:**
600V category III and pollution degree 2
- Influence of adjacent conductor:**
≤ 15 mA / A at 50 Hz
- Influence of conductor position in jaws:**
≤ 0.5% of output signal at 50/60 Hz
- Load influence:**
From 0.2 .. 10 Ω
< 0.5 % on measurement
< 0.5 ° on phase
- Influence of frequency ⁽²⁾:**
< 3 % of output signal from 40 Hz .. 1kHz
< 12 % of output signal from 1 kHz .. 10 kHz

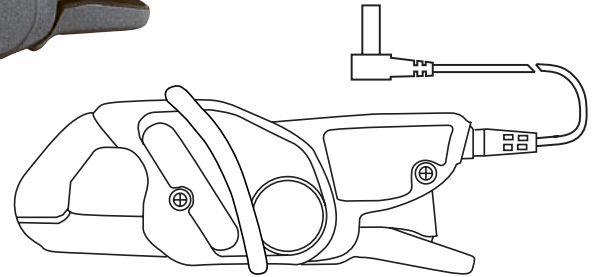
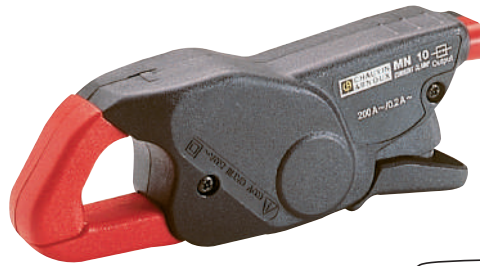

Mechanical specifications

- Influence of crest factor:**
< 4 % of output signal for a crest factor of 3 and current 200 A_{RMS}
- Operating temperature:**
-10°C to +55°C
- Storage temperature:**
-40°C to +70°C
- Influence of temperature:**
≤ 0.15 % of output signal per 10 °K
- Relative humidity for operation:**
0 to 85 % RH with a linear decrease above 35 °C
- Influence of relative humidity:**
< 0.2 % of output signal from 10 % to 85 % RH
- Operating altitude:**
0 to 2,000 m
- Max. jaw opening:**
20 mm
- Clamping capacity:**
Cable: Ø max 20 mm
Busbar: 1 busbar of 20 x 5mm
- Casing protection rating:**
IP40 (IEC 529)
- Drop test:**
1 m (IEC 68-2-32)
- Shock resistance:**
100 g (IEC 68-2-27)

- Vibration resistance:**
10 / 55/10 Hz, 0.15 mm (IEC 68-2-6)
- Self-extinguishing capability:**
Casing: UL94 V2
Jaws: UL94 V0
- Dimensions:**
135 x 51 x 30 mm
- Weight:**
180 g
- Colour:**
Dark grey case with red jaws
- Output:**
MN10: safety sockets (4 mm)
MN11: Two-wire cable with reinforced insulation or double insulation, 1.5 m in length, terminated with 2 elbowed male safety plug connectors (4 mm)

Safety specifications

- Electrical safety:**
Instrument with double insulation or reinforced insulation between the primary, the secondary and the grippable part located under the guard as per IEC 1010-1 & IEC 1010-2-032
 - 600 V category III, pollution degree 2
 - 300 V category IV, pollution degree 2
- Electromagnetic compatibility (EMC) :**
EN 50081-1: class B
EN 50082-2:
 - Electrostatic discharge: IEC 1000-4-2
 - Radiated field: IEC 1000-4-3
 - Fast transients: IEC 1000-4-4
 - Magnetic field at 50/60Hz: IEC 1000-4-8

(1) Conditions of reference: 23 °C ± 3 °K, 20 to 70 % RH, sinusoidal signal with frequency of 48 Hz to 65 Hz, external magnetic field < 40 A/m, no DC components, no external conductor with circulating current, conductor centred for measurement, 1 Ω load.

(2) Out of reference domain.

To order	Reference
AC current clamp model MN10 with operating manual	P01120403
AC current clamp model MN11 with operating manual	P01120404

CURRENT CLAMPS FOR AC CURRENT

Models MN12 and MN13

Current	200 AC
Output	10 mV / A

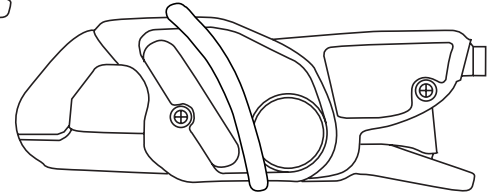
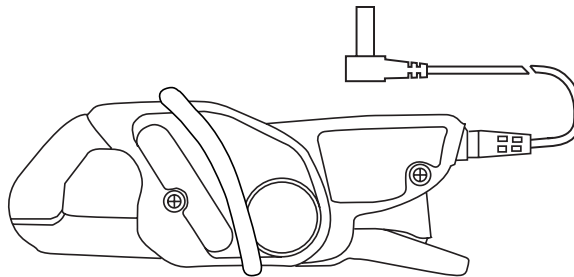

Electrical specifications

- Current range:**
0.5 A AC .. 240 A AC
- Output signal:**
10 mV AC / A AC (2.4 V for 240 A)
- Accuracy and phase shift ⁽¹⁾:**

Primary current:	0.5 A .. 10 A	10 A .. 40 A	40 A .. 100 A	100 A .. 240 A
Accuracy in % of output signal	≤ 3.5% + 5 mV	≤ 2.5% + 5 mV	≤ 2% + 5 mV	≤ 1% + 5 mV
Phase shift	not specified	≤ 5°	≤ 3°	≤ 2.5°

- Bandwidth:**
40 Hz .. 10 kHz
- Crest factor:**
3 for a current of 200 A_{RMS}
- Maximum currents:**
200 A continuous for a frequency ≤ 3 kHz (limitation proportional to the inverse of one third of frequency beyond)
- Load impedance:**
> 1 MΩ
- Operating voltage:**
600 V_{RMS}
- Common mode voltage:**
600V category III and pollution degree 2
- Influence of adjacent conductor:**
≤ 15 mA / A at 50 Hz
- Influence of conductor position in jaws:**
≤ 0.5% of output signal at 50/60 Hz
- Influence of frequency ⁽²⁾:**
< 3 % of output signal from 40 Hz .. 1kHz
< 12 % of output signal from 1 kHz .. 10 kHz
- Influence of crest factor:**
< 4 % of output signal for a crest factor of 3 and current 200 A_{RMS}
- Influence of temperature:**
≤ 0.15 % of output signal per 10 °K
- Relative humidity for operation:**
0 to 85 % RH with a linear decrease above 35 °C
- Influence of relative humidity:**
< 0.2 % of output signal from 10 % to 85 % RH
- Operating altitude:**
0 to 2,000 m
- Max. jaw opening:**
20 mm
- Clamping capacity:**
Cable: Ø max 20 mm
Busbar: 1 busbar of 20 x 5mm
- Casing protection rating:**
IP40 (IEC 529)
- Drop test:**
1 m (IEC 68-2-32)
- Vibration resistance:**
10 / 55/10 Hz, 0.15 mm (IEC 68-2-6)
- Self-extinguishing capability:**
Casing: UL94 V2
Jaws: UL94 V0
- Dimensions:**
135 x 51 x 30 mm
- Weight:**
180 g
- Colour:**
Dark grey case with red jaws

- Output:**
MN12: Safety sockets (4mm)
MN13: Two-wire cable with reinforced insulation or double insulation, length 1.5 m, terminated by 2 insulated elbowed male banana plugs (4 mm)

Safety specifications

- Electrical safety:**
Instrument with double insulation or reinforced insulation between the primary, the secondary and the grippable part located under the guard as per EN 61010-1 Ed. 2:2001, EN 61010-2-031 Ed. 2002 & EN 61010-2-032 Ed. 2003
- 600 V category III, pollution degree 2
- 300 V category IV, pollution degree
- Electromagnetic compatibility (EMC) :**
EN 50081-1: class B
EN 50082-2:
- Electrostatic discharge: IEC 1000-4-2
- Radiated field: IEC 1000-4-3
- Fast transients: IEC 1000-4-4
- Magnetic field at 50/60Hz: IEC 1000-4-8

Mechanical specifications

- Operating temperature:**
-10°C to +55°C
- Storage temperature:**
-40°C to +70°C

(1) Conditions of reference: 23 °C ± 3 °K, 20 to 70 % RH, sinusoidal signal with frequency of 48Hz to 65 Hz, external magnetic field < 40 A/m, no DC components, no external conductor with circulating current, conductor centred for measurement, load impedance > 1 MΩ.

(2) Out of reference domain

To order	Reference
AC current clamp model MN12 with operating manual	P01120405
AC current clamp model MN13 with operating manual	P01120406

CURRENT CLAMPS FOR AC CURRENT

Models MN14 and MN15

Current	200 A AC
Output	1 mV / A

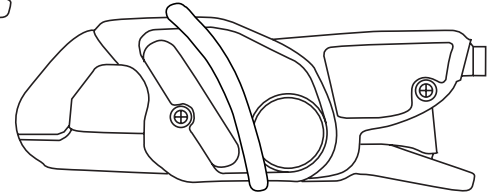
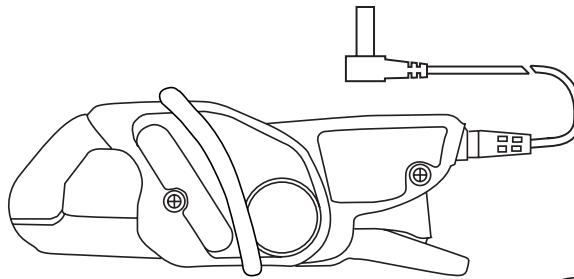

Electrical specifications

- Current range:**
0.5 A AC .. 240 A AC
- Output signal:**
1 mV AC / A AC (240 mV for 240 A)
- Accuracy and phase shift ⁽¹⁾:**

Primary current:	0.5 A .. 10 A	10 A .. 40 A	40 A .. 100 A	100 A .. 240 A
Accuracy in % of output signal	≤ 3% + 5 mV	≤ 2.5% + 5 mV	≤ 2% + 5 mV	≤ 1% + 5 mV
Phase shift	not specified	≤ 5°	≤ 3°	≤ 2.5°

- Bandwidth:**
40 Hz .. 10 kHz
- Crest factor:**
3 for a current of 200 A_{RMS}
- Maximum currents:**
200 A continuous for a frequency ≤ 3 kHz (limitation proportional to the inverse of one third of frequency beyond)
- Load impedance:**
> 1 MΩ
- Common mode voltage:**
600 V category III and pollution degree 2
- Influence of adjacent conductor:**
≤ 15 mA / A at 50 Hz
- Load influence:**
≤ 0.5% of output signal at 50/60 Hz
- Influence of frequency ⁽²⁾:**
< 3 % of output signal from 40 Hz .. 1kHz
< 12 % of output signal from 1 kHz .. 10 kHz
- Influence of crest factor:**
< 3 % of output signal for a crest factor of 3 and current 200 A_{RMS}

- Relative humidity for operation:**
0 to 85 % RH with a linear decrease above 35 °C
- Influence of relative humidity:**
< 0.2 % of output signal from 10 % to 85 % RH
- Operating altitude:**
0 to 2,000 m
- Max. jaw opening:**
20 mm
- Clamping capacity:**
Cable: Ø max 20 mm
Busbar: 1 busbar of 20 x 5mm
- Casing protection rating:**
IP40 (IEC 529)
- Drop test:**
1 m (IEC 68-2-32)
- Shock resistance:**
100 g (IEC 68-2-27)
- Vibration resistance:**
10 / 55/10 Hz, 0.15 mm (IEC 68-2-6)
- Self-extinguishing capability:**
Casing: UL94 V2
Jaws: UL94 V0
- Dimensions:**
135 x 51 x 30 mm
- Weight:**
180 g
- Colour:**
Dark grey case with red jaws
- Output:**
MN14: Safety sockets (4mm)

MN15: Two-wire cable with reinforced insulation or double insulation, length 1.5 m, terminated by 2 insulated elbowed male banana plugs (4 mm)

Safety specifications

- Electrical safety:**
Instrument with double insulation or reinforced insulation between the primary, the secondary and the grippable part located under the guard as per IEC 1010-1 & IEC 1010-2-032
 - 600 V category III, pollution degree 2
 - 300 V category IV, pollution degree 2
- Electromagnetic compatibility (EMC):** :
EN 50081-1: class B
EN 50082-2:
 - Electrostatic discharge: IEC 1000-4-2
 - Radiated field: IEC 1000-4-3
 - Fast transients: IEC 1000-4-4
 - Magnetic field at 50/60Hz: IEC 1000-4-8

Mechanical specifications

- Operating temperature:**
-10°C to +55°C
- Storage temperature:**
-40°C to +70°C
- Influence of temperature:**
≤ 0.15 % of output signal per 10 °K

(1) Conditions of reference: 23 °C ± 3 °K, 20 to 70 % RH, sinusoidal signal with frequency of 48Hz to 65 Hz, external magnetic field < 40 A/m, no DC components, no external conductor with circulating current, conductor centred for measurement, load impedance > 1 MΩ.

(2) Out of reference domain.

To order	Reference
AC current clamp model MN14 with operating manual	P01120416
AC current clamp model MN15 with operating manual	P01120417

CURRENT CLAMPS FOR AC CURRENT

Model MN21

Current	200 A AC
Ratio	1,000/1
Output	1 mA / A

Description

An electronic voltage-limiting system protects output of clamp when operating, if the secondary circuit is opened.

Electrical specifications

- Current range:**
0.1 A AC .. 240 A AC
- Turns Ratio:**
1,000/1
- Output signal:**
1 mA AC / A AC (240 mA for 240 A)
- Accuracy and phase shift ⁽¹⁾:**

Primary current:	0.1 A .. 10 A	1 A .. 20 A	20 A .. 80 A	80 A .. 150 A	150 A .. 200 A
Accuracy in % of output signal	≤ 2% + 20 μA	≤ 1% + 20 μA	≤ 1%	≤ 2%	≤ 4%
Phase shift	not specified	≤ 2°	≤ 1.5°	≤ 1.5°	≤ 2°

- Bandwidth:**
40 Hz .. 10 kHz
- Crest factor:**
3 for a current of 200 A_{RMS}
- Maximum currents:**
200 A continuous for a frequency ≤ 3 kHz (limitation proportional to the inverse of one third of frequency beyond)
- Load impedance:**
≤ 10 Ω
- Operating voltage:**
600 V_{RMS}
- Maximum output voltage (secondary open):**
Limited to 8 V peak max.
- Operating voltage:**
600 V_{RMS}
- Common mode voltage:**
600V category III and pollution degree 2
- Influence of adjacent conductor:**
≤ 15 mA / A at 50 Hz
- Influence of conductor position in jaws:**
≤ 0.5% of output signal at 50/60 Hz
- Load influence:**
From 0.1 .. 5 Ω
< 0.5 % on measurement
- Influence of frequency $I_p < 150 A$ ⁽²⁾:**
< 5 % of output signal from 40 Hz .. 1kHz
< 15 % of output signal from 1 kHz .. 10 kHz
add 5 % error if 150 A < I_p < 200 A

- Influence of crest factor:**
< 3 % of output signal for crest factor < 5 with current < 280 A peak (50 A_{RMS})

Mechanical specifications

- Operating temperature:**
-10°C to +55°C
- Storage temperature:**
-40°C to +70°C
- Influence of temperature:**
≤ 0.15 % of output signal per 10 °K
- Relative humidity for operation:**
0 to 85 % RH with a linear decrease above 35 °C
- Influence of relative humidity:**
< 0.2 % of output signal from 10 % to 85 % RH
- Operating altitude:**
0 to 2,000 m
- Max. jaw opening:**
20 mm
- Clamping capacity:**
Cable: Ø max 20 mm
Busbar: 1 busbar of 20 x 5mm
- Casing protection rating:**
IP40 (IEC 529)
- Drop test:**
1 m (IEC 68-2-32)
- Shock resistance:**
100 g (IEC 68-2-27)



- Vibration resistance:**
10 / 55/10 Hz, 0.15 mm (IEC 68-2-6)
- Self-extinguishing capability:**
Casing: UL94 V2
Jaws: UL94 V0
- Dimensions:**
135 x 51 x 30 mm
- Weight:**
180 g
- Colour:**
Dark grey case with red jaws
- Output:**
Two-wire cable with reinforced insulation or double insulation, length 1.5 m, terminated by 2 insulated elbowed male banana plugs (4 mm)

Safety specifications

- Electrical safety:**
Instrument with double insulation or reinforced insulation between the primary, the secondary and the grippable part located under the guard as per IEC 1010-1 & IEC 1010-2-032
- 600 V category III, pollution degree 2
- 300 V category IV, pollution degree 2
- Electromagnetic compatibility (EMC) :**
EN 50081-1: class B
EN 50082-2:
- Electrostatic discharge: IEC 1000-4-2
- Radiated field: IEC 1000-4-3
- Fast transients: IEC 1000-4-4
- Magnetic field at 50/60Hz: IEC 1000-4-8

(1) Conditions of reference: 23 °C ± 3 °K, 20 to 70 % RH, sinusoidal signal with frequency of 48 Hz to 65 Hz, external magnetic field < 40 A/m, no DC components, no external conductor with circulating current, conductor centred for measurement, 1 Ω load.

(2) Out of reference domain.

To order	Reference
AC current clamp model MN21 with operating manual	P01120418

CURRENT CLAMPS FOR AC CURRENT

Model MN23

Current	200 A AC
Output	10 mV / A

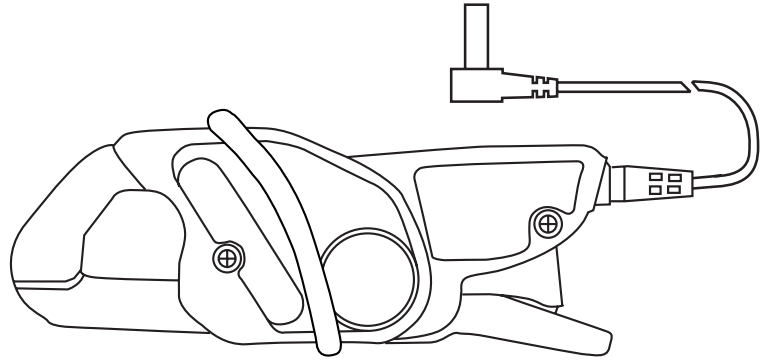

Electrical specifications

- Current range:**
0.5 A AC .. 240 A AC
- Output signal:**
1 mV AC / A AC (240 mV for 240 A)
- Accuracy and phase shift ⁽¹⁾:**

Primary current:	0.1 A .. 1 A	1 A .. 20 A	20 A .. 80 A	80 A .. 150 A	150 A .. 200 A
Accuracy in % of output signal	≤ 3% + 200 μA	≤ 2% + 200 μA	≤ 1%	≤ 4%	≤ 10%
Phase shift	not specified	≤ 3°	≤ 2°	≤ 2.5°	≤ 3.5°

- Bandwidth:**
40 Hz .. 10 kHz
- Crest factor:**
5 for a current of 280 A peak
- Maximum currents:**
200 A continuous for a frequency ≤ 3 kHz (limitation proportional to the inverse of one third of frequency beyond)
- Load impedance:**
≤ 10 Ω
- Operating voltage:**
600 V_{RMS}
- Maximum output voltage (secondary open):**
Limited to 8 V peak max.
- Operating voltage:**
600 V_{RMS}
- Common mode voltage:**
600V category III and pollution degree 2
- Influence of adjacent conductor:**
≤ 15 mA / A at 50 Hz
- Influence of conductor position in jaws:**
≤ 0.5% of output signal at 50/60 Hz
- Influence of frequency $I_p < 100 A$ ⁽²⁾:**
< 5 % of output signal from 40 Hz .. 1 kHz**
< 15 % of output signal from 1 kHz .. 10 kHz
** add 10 % error if 100 < I_p < 200 A
- Influence of crest factor:**
< 3 % of output signal for crest factor
< 5 with current < 280 A peak (50 A_{RMS})

Mechanical specifications

- Operating temperature:**
-10°C to +55°C
- Storage temperature:**
-40°C to +70°C
- Influence of temperature:**
≤ 0.20 % of output signal per 10 °K
- Relative humidity for operation:**
0 to 85 % RH with a linear decrease above 35 °C
- Influence of relative humidity:**
< 0.2 % of output signal from 10 % to 85 % RH
- Operating altitude:**
0 to 2,000 m
- Max. jaw opening:**
20 mm
- Clamping capacity:**
Cable: Ø max 20 mm
Busbar: 1 busbar of 20 x 5mm
- Casing protection rating:**
IP40 (IEC 529)
- Drop test:**
1 m (IEC 68-2-32)
- Shock resistance:**
100 g (IEC 68-2-27)
- Vibration resistance:**
10 / 55/10 Hz, 0.15 mm (IEC 68-2-6)
- Self-extinguishing capability:**
Casing: UL94 V2
Jaws: UL94 V0

- Dimensions:**
135 x 51 x 30 mm
- Weight:**
180 g
- Colour:**
Dark grey case with red jaws
- Output:**
Two-wire cable with reinforced insulation or double insulation, length 1.5 m, terminated by 2 insulated elbowed male banana plugs (4 mm)

Safety specifications

- Electrical safety:**
Instrument with double insulation or reinforced insulation between the primary, the secondary and the grippable part located under the guard as per IEC 1010-1 & IEC 1010-2-032
- 600 V category III, pollution degree 2
- 300 V category IV, pollution degree 2
- Electromagnetic compatibility (EMC) :**
EN 50081-1: class B
EN 50082-2:
- Electrostatic discharge: IEC 1000-4-2
- Radiated field: IEC 1000-4-3
Fast transients: IEC 1000-4-4
Magnetic field at 50/60Hz: IEC 1000-4-8

(1) Conditions of reference: 23 °C ± 3 °K, 20 to 70 % RH, sinusoidal signal with frequency of 48 Hz to 65 Hz, external magnetic field < 40 A/m, no DC components, no external conductor with circulating current, conductor centred for measurement, 1 Ω load.
(2) Out of reference domain.

To order	Reference
AC current clamp model MN23 with operating manual	P01120419

CURRENT CLAMPS FOR AC CURRENT

Models MN38 and MN39

Current	20 A AC	200 A AC
Output	100 mV / A	10 mV / A



Electrical specifications

- Current range:**
0.1 A AC .. 24 A AC
0.5 A AC.. 240 A AC
- Output signal:**
100 mV AC / A AC (2.4 V for 24 A)
10 mV AC / A AC (2.4 V for 240 A)
- Accuracy and phase shift ⁽¹⁾:**

Calibre	20 A	200 A			
Primary current:	0.1 A .. 20 A	0.5 A .. 10 A	10 A .. 40 A	40 A .. 100 A	100 A .. 240 A
Accuracy in % of output signal	≤ 1% + 50 mV	≤ 3% + 5 mV	≤ 2,5% + 5 mV	≤ 2% + 5 mV	≤ 1% + 5 mV
Phase shift	not specified	not specified	≤ 5°	≤ 3°	≤ 2,5°

- Bandwidth:**
40 Hz .. 10 kHz
- Crest factor:**
3 for a current of 200 A_{RMS}
- Maximum currents:**
200 A continuous for a frequency ≤ 3 kHz (limitation proportional to the inverse of one third of frequency beyond)
- Load impedance:**
≤ 10 Ω
- Operating voltage:**
600 V_{RMS}
- Common mode voltage:**
600V category III and pollution degree 2
- Influence of adjacent conductor:**
≤ 15 mA / A at 50 Hz
- Influence of conductor position in jaws:**
≤ 0.5% of output signal at 50/60 Hz
- Load influence:**
From 0.2 .. 10 Ω
< 0.5 % on measurement
< 0.5 ° on phase
- Influence of frequency ⁽²⁾:**
- 20 A calibre:
< 5 % of output signal from 40 Hz .. 1kHz

< 15 % of output signal from 1 kHz .. 10 kHz
- 200 A calibre:
< 3 % of output signal from 40 Hz .. 1kHz

< 12 % of output signal from 1 kHz .. 10 kHz
- Influence of crest factor:**
< 3 % of output signal for a crest factor of 3 and current 200 A_{RMS}

Mechanical specifications

- Operating temperature:**
-10°C to +55°C
- Storage temperature:**
-40°C to +70°C
- Influence of temperature:**
≤ 0.15 % of output signal per 10 °K
- Relative humidity for operation:**
0 to 85 % RH with a linear decrease above 35 °C
- Influence of relative humidity:**
< 0.2 % of output signal from 10 % to 85 % RH
- Operating altitude:**
0 to 2,000 m
- Max. jaw opening:**
20 mm
- Clamping capacity:**
Cable: Ø max 20 mm
Busbar: 1 busbar of 20 x 5mm
- Casing protection rating:**
IP40 (IEC 529)
- Drop test:**
1 m (IEC 68-2-32)
- Shock resistance:**
100 g (IEC 68-2-27)
- Vibration resistance:**
10 / 55/10 Hz, 0.15 mm (IEC 68-2-6)
- Self-extinguishing capability:**
Casing: UL94 V2
Jaws: UL94 V0
- Dimensions:**
135 x 51 x 30 mm

- Weight:**
180 g
- Colour:**
Dark grey case with red jaws
- Output:**
MN38: Safety sockets (4mm)
MN39: Two-wire cable with reinforced insulation or double insulation, length 1.5 m, terminated by 2 insulated elbowed male banana plugs (4 mm)

Safety specifications

- Electrical safety:**
Instrument with double insulation or reinforced insulation between the primary, the secondary and the grippable part located under the guard as per IEC 1010-1 & IEC 1010-2-032
- 600 V category III, pollution degree 2
- 300 V category IV, pollution degree 2
- Electromagnetic compatibility (EMC):** :
EN 50081-1: class B
EN 50082-2:
- Electrostatic discharge: IEC 1000-4-2
- Radiated field: IEC 1000-4-3
- Fast transients: IEC 1000-4-4
- Magnetic field at 50/60Hz: IEC 1000-4-8

(1) Conditions of reference: 23 °C ± 3 °K, 20 to 70 % RH, sinusoidal signal with frequency of 48Hz to 65 Hz, external magnetic field < 40 A/m, no DC components, no external conductor with circulating current, conductor centred for measurement, load impedance > 1 MΩ.

(2) Out of reference domain

To order	Reference
AC current clamp model MN38 with operating manual	P01120407
AC current clamp model MN39 with operating manual	P01120408

CURRENT CLAMPS FOR AC CURRENT

Model MN60 (insulated AC current probe)

Current	60 A peak	600 A peak
Output	100 mV / A	10 mV / A

Description

This 200 A AC clamp enables easy display and measurement of "current" curves.

It fits any oscilloscope since it has a coaxial lead with BNC plug.

It produces a mV signal directly proportional to current. It offers 2 different sensitivities.



Electrical specifications

- Current range:**
0.1 A AC .. 20 A AC (60 A peak)
0.5 A AC .. 200 A AC (600 A peak)
- Output signal:**
100 mV AC / A AC (2 V for 20 A)
10 mV AC / A AC (2 V for 200 A)
- Accuracy and phase shift ⁽¹⁾:**

Calibre	20 A		200 A		
Primary current:	0.1 A .. 20 A	0.5 A .. 10 A	10 A .. 40 A	40 A .. 100 A	100 A .. 240 A
Accuracy in % of output signal	≤ 2% + 50 mV	≤ 3.5% + 5 mV	≤ 3% + 5 mV	≤ 2.5% + 5 mV	≤ 1.5% + 5 mV
Phase shift	not specified	not specified	≤ 6°	≤ 4°	≤ 3°

- Bandwidth:**
40 Hz .. 40 kHz (-3 dB) (depending on current value)
- Rise/fall time from 10 % to 90 %:**
20 A calibre: 7.4 μs
200 A calibre: 8.7 μs
- 10 % delay time:**
0.1 μs
- Ampere second product:**
20 A calibre: 25 A.s
200 A calibre: 2 A.s
- Insertion impedance (at 400 Hz / 10 kHz)**
20 A calibre: < 0.3 mΩ / < 7.2 mΩ
200 A calibre: < 1 mΩ / < 26 mΩ
- Maximum currents:**
200 A continuous for a frequency ≤ 3 kHz (limitation proportional to the inverse of one third of frequency beyond)
- Influence of temperature:**
≤ 150 ppm /k or 0.15 % of output signal per 10 °K
- Influence of relative humidity:**
< 0.2 % of output signal
- Influence of adjacent conductor:**
≤ 15 mA / A at 50 Hz
- Influence of DC current < 10 % of rated calibre superimposed on the rated current:**
20 A calibre: For I DC < 2 A: influence < 0.5 %
200 A calibre: For I DC < 20 A: influence < 5 %
- Influence of conductor position in jaws:**
≤ 0.5% of output signal at 50/60 Hz
- Influence of crest factor:**
< 3 % of output signal for a crest factor of 3 and current of 200 A_{RMS}

- Influence of frequency ⁽²⁾:**
 - 20 A calibre:
< 10 % of output signal from 40 Hz .. 1 kHz
< 15 % of output signal from 1 kHz .. 10 kHz
 - 200 A calibre:
< 3 % of output signal from 40 Hz .. 1 kHz
< 12 % of output signal from 1 kHz .. 10 kHz

Mechanical specifications

- Operating temperature:**
-10°C to +55°C
- Storage temperature:**
-40°C to +70°C
- Relative humidity for operation:**
0 to 85 % RH with a linear decrease above 35°C
- Influence of relative humidity:**
< 0.2 % of output signal from 10 % to 85 % RH
- Operating altitude:**
0 to 2,000 m
- Max. jaw opening:**
20 mm
- Casing protection rating:**
IP40 (IEC 529)
- Drop test:**
1 m (IEC 68-2-32)
- Shock resistance:**
100 g / 6 ms / half-period (IEC 68-2-27)
- Protection against impacts:**
IK04 0.5 J (EN 50102)

- Vibration resistance:**
10 / 55/10 Hz, 0.15 mm (IEC 68-2-6)
- Self-extinguishing capability:**
Casing: UL94 V2
Jaws: UL94 V0
- Dimensions:**
128 x 49 x 28 mm
- Weight:**
180 g
- Colour:**
Dark grey case with red jaws
- Output:**
Coaxial cable 2 m long, terminated by an insulated BNC connector

Safety specifications

- Electrical safety:**
Instrument with double insulation or reinforced insulation between the primary, the secondary and the grippable part located under the guard as per IEC 1010-1 & IEC 1010-2-032
 - 600 V category III, pollution degree 2
 - 300 V category IV, pollution degree 2
- Electromagnetic compatibility (EMC):** : EN 50081-1: class B
EN 50082-2:
 - Electrostatic discharge: IEC 1000-4-2
4 kV level 2 performance criterion B
8 kV in the air level 3 performance criterion B
 - Radiated field: IEC 1000-4-3
10 V/m performance criterion A
 - Fast transients: IEC 1000-4-4
1 kV level 2 performance criterion B
2 kV level 3 performance criterion B
 - Magnetic field at 50/60Hz:
IEC 1000-4-8 field of 400 A/m at 50 Hz: < 1 A

CURRENT CLAMPS FOR AC CURRENT

Model MN60 (insulated AC current probe)

Curves at 50 Hz

200 A calibre

20 A calibre

Error on measurement

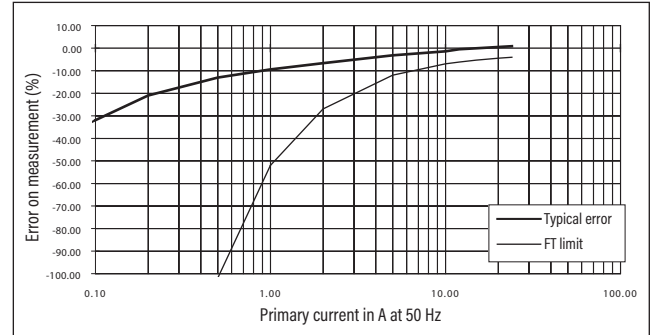
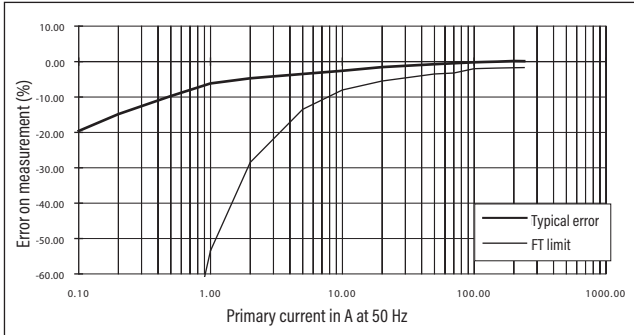

Phase shift

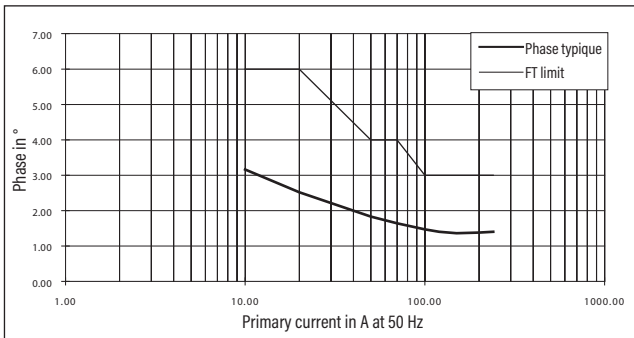

Frequency response

200 A calibre

20 A calibre

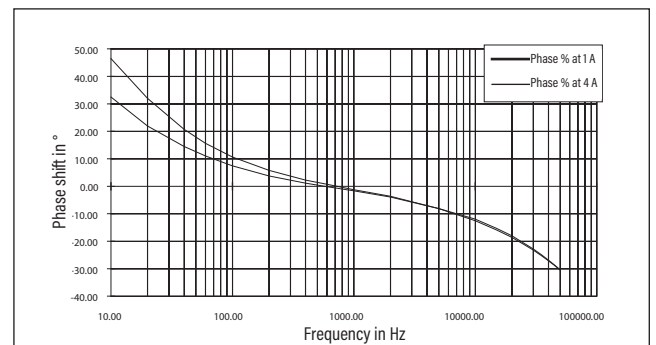
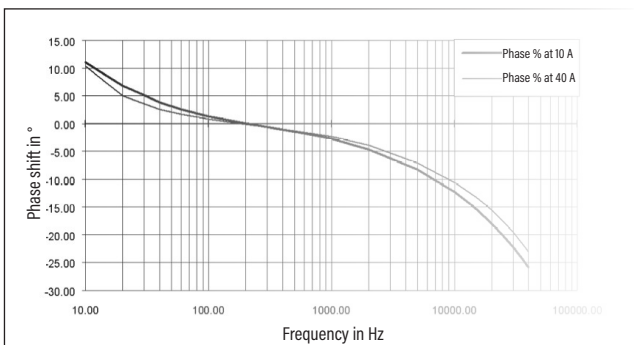
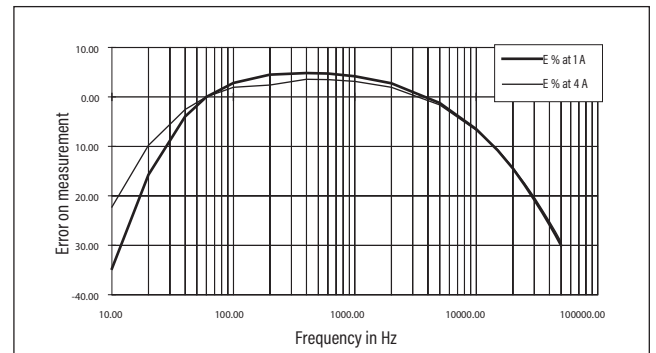
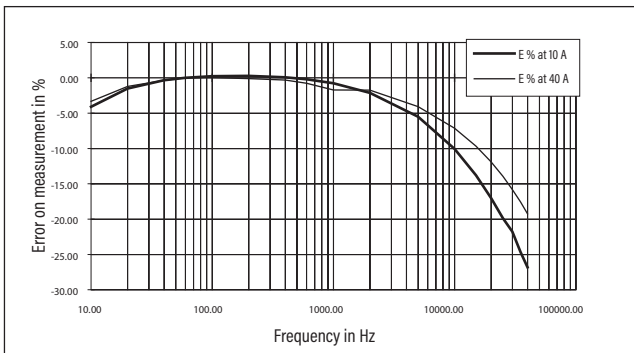

CURRENT CLAMPS FOR AC CURRENT

Model MN60 (insulated AC current probe)

Frequency response (cont.)

200 A calibre

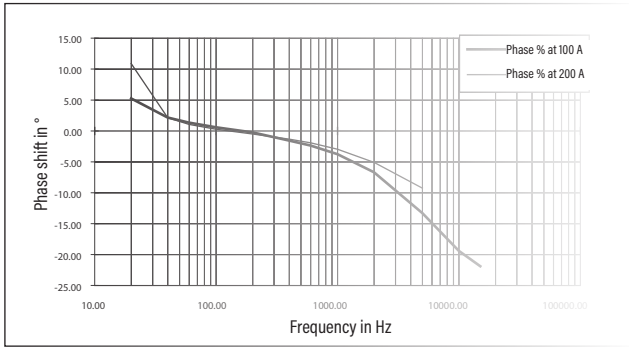
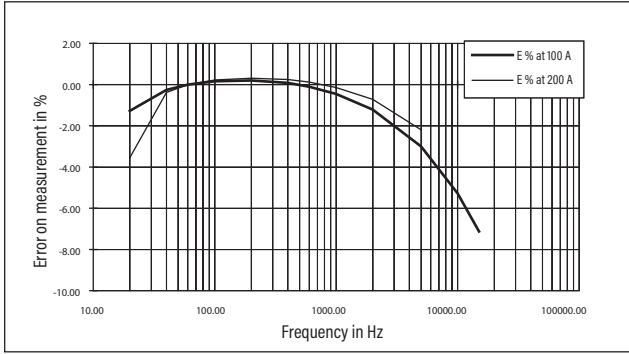

20 A calibre

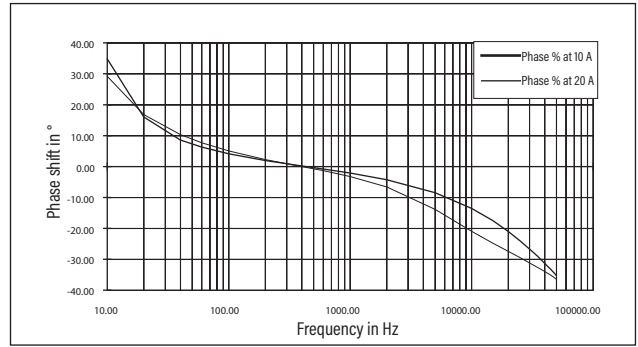
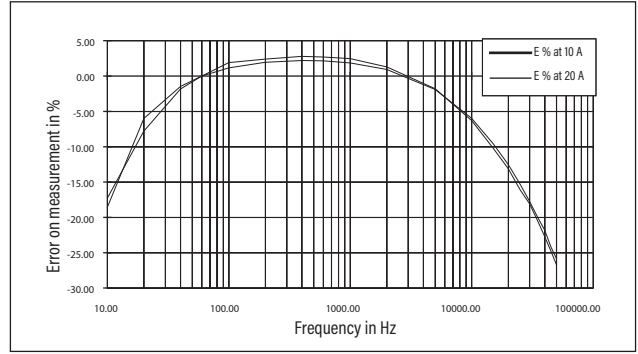

Response to a square signal

200 A calibre

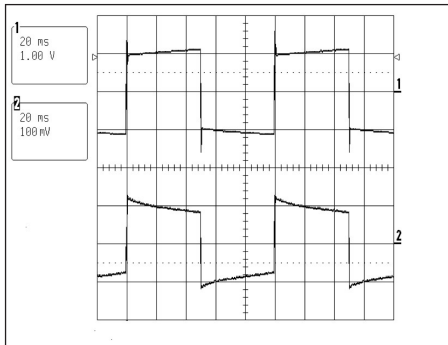

10 A at 10 Hz

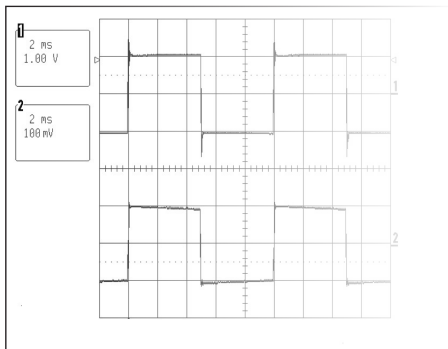
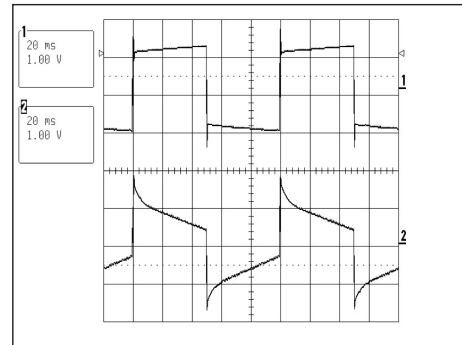

10 A at 100 Hz

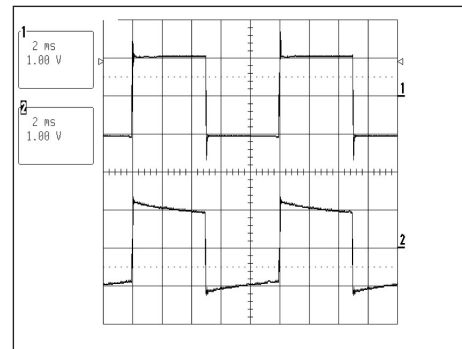

CURRENT CLAMPS FOR AC CURRENT

Model MN60 (insulated AC current probe)

Response to a square signal (cont.)

200 A calibre

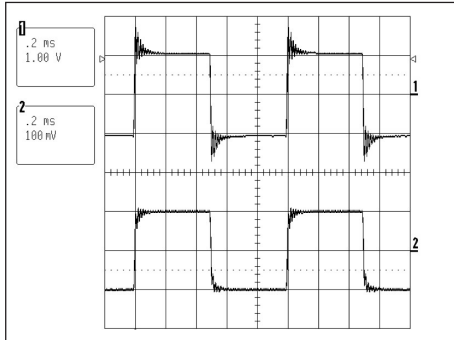

10 A at 1 kHz

20 A calibre

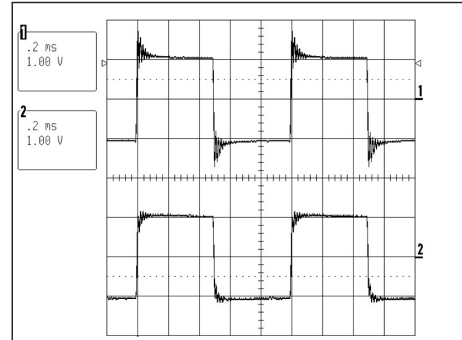

10 A at 10 kHz

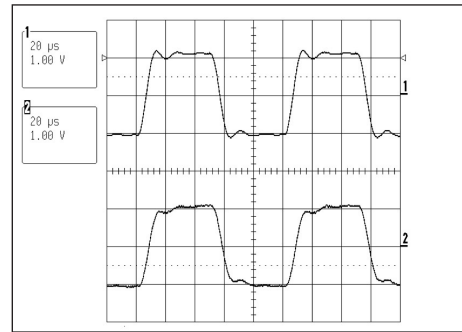
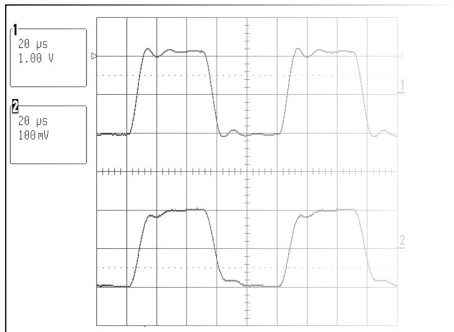

(1) Conditions of reference: 23 °C ± 3 °K, 20 % to 75 % RH, sinusoidal signal with frequency of 48 Hz at 1 kHz, external magnetic field < 40 A/m, no DC components, no external conductor with circulating current, conductor centred for measurement, load impedance > 1 MΩ and < 100 pF.

(2) Out of reference domain

To order	Reference
AC current clamp model MN60 for oscilloscope with operating manual	P01120409

CURRENT CLAMPS FOR AC CURRENT

Model MN71

Current	10 A AC
Output	100 mV / A

Description

This clamp was specially designed to measure current on current transformer secondary circuits.

Electrical specifications

- Current range:**
0.01 A AC .. 12 A AC
- Output signal:**
100 mV AC / A AC (1.2 V for 12 A)
- Accuracy and phase shift ⁽¹⁾:**

Primary current:	0.01 A .. 0.1 A	0.1 A .. 1 A	1 A .. 5 A	5 A .. 12 A
Accuracy in % of output signal	≤ 3% + 0.1 mV	≤ 2.5%	≤ 1%	
Phase shift	not specified	≤ 5°	≤ 3°	≤ 3°

- Bandwidth:**
40 Hz .. 10 kHz
- Crest factor:**
5 for a current of 40 A peak (8 A_{RMS})
- Maximum currents:**
200 A continuous for a frequency ≤ 3 kHz (limitation proportional to the inverse of one third of frequency beyond)
- Load impedance:**
> 1 MΩ
- Operating voltage:**
600 V_{RMS}
- Common mode voltage:**
600V category III and pollution degree 2
- Influence of adjacent conductor:**
< 15 mA / A at 50 Hz
- Influence of conductor position in jaws:**
< 0.5% of output signal at 50/60 Hz
- Influence of frequency ⁽²⁾:**
< 5 % of output signal from 20 Hz .. 1 kHz
< 10 % of output signal from 1 kHz .. 10 kHz
- Influence of crest factor:**
< 3 % of output signal for a crest factor < 5 with current < 40 A_{RMS}

Mechanical specifications

- Operating temperature:**
-10°C to +55°C
- Storage temperature:**
-40°C to +70°C
- Influence of temperature:**
≤ 0.2 % of output signal per 10 °K
- Relative humidity for operation:**
0 to 85 % RH with a linear decrease above 35 °C
- Influence of relative humidity:**
< 0.2 % of output signal from 10 % to 85 % RH
- Operating altitude:**
0 to 2,000 m
- Max. jaw opening:**
20 mm
- Clamping capacity:**
Cable: Ø max 20 mm
Busbar: 1 busbar of 20 x 5mm
- Casing protection rating:**
IP40 (IEC 529)
- Drop test:**
1 m (IEC 68-2-32)
- Shock resistance:**
100 g (IEC 68-2-27)
- Vibration resistance:**
10 / 55/10 Hz, 0.15 mm (IEC 68-2-6)

- Self-extinguishing capability:**
Casing: UL94 V2
Jaws: UL94 V0
- Dimensions:**
135 x 51 x 30 mm
- Mass:**
180 g
- Colours:**
Dark grey case with red jaws
- Output:**
1.5 m two-wire lead with double or reinforced insulation terminated by 2 elbowed male safety plugs (4 mm)

Safety specifications

- Electrical safety:**
Instrument with double insulation or reinforced insulation between the primary, the secondary and the grippable part located under the guard as per IEC 1010-1 & IEC 1010-2-032
 - 600 V category III, pollution degree 2
 - 300 V category IV, pollution degree 2
- Electromagnetic compatibility (EMC) :**
EN 50081-1: class B
EN 50082-2:
 - Electrostatic discharge: IEC 1000-4-2
 - Radiated field: IEC 1000-4-3
 - Fast transients: IEC 1000-4-4
 - Magnetic field at 50 Hz: IEC 1000-4-8

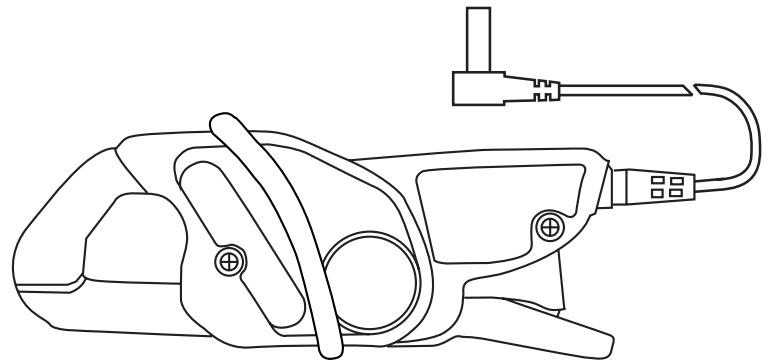

(1) Conditions of reference: 23 °C ± 3 °K, 20 % to 75 % RH, sinusoidal signal with frequency of 48Hz to 65 Hz, external magnetic field < 40 A/m, no DC components, no external conductor with circulating current, conductor centred for measurement, load impedance > 1 MΩ.

(2) Out of reference domain

To order	Reference
AC current clamp model MN71 with operating manual	P01120420

CURRENT CLAMPS FOR AC CURRENT

Model MN73

Current	2 A AC	200 A AC
Output	1,000 mV / A	10 mV / A

Description

This clamp has a wide measurement range (up to 200 A), and it can also measure very low currents. We call it the "universal" probe.

Electrical specifications

- Current range:**
0.01 A AC .. 2.4 A AC
0.1 A AC, 240 A AC
- Output signal:**
1,000 mV AC / A AC (2 V for 2 A)
10 mV AC / A AC (2.4 V for 240 A)
- Accuracy and phase shift ⁽¹⁾:**

Calibre	2 A				200 A				
	0.01 A .. 0.1 A	0.1 A .. 1 A	1 A .. 2 A	2 A .. 2.4 A	0.1 A .. 1 A	1 A .. 20 A	20 A .. 80 A	80 A .. 150 A	150 A .. 200 A
Primary current:	0.01 A .. 0.1 A	0.1 A .. 1 A	1 A .. 2 A	2 A .. 2.4 A	0.1 A .. 1 A	1 A .. 20 A	20 A .. 80 A	80 A .. 150 A	150 A .. 200 A
Accuracy in % of output signal	≤ 5 % + 2 mV	≤ 3 % + 1 mV	≤ 1 %	≤ 1 %	≤ 3 % + 200 μV	≤ 2 % + 200 μV	≤ 1 %	≤ 4 %	≤ 10 %
Phase shift	not specified				not specified	≤ 3°	≤ 2°	≤ 3°	≤ 4°

- Bandwidth:**
40 Hz .. 10 kHz
- Crest factor:**
5 for a current of 280 A peak (200 A_{RMS})
- Maximum currents:**
200 A continuous for a frequency ≤ 1 kHz (limitation proportional to the inverse frequency beyond)
- Load impedance:**
> 1 MΩ
- Operating voltage:**
600 V_{RMS}
- Common mode voltage:**
600V category III and pollution degree 2
- Influence of adjacent conductor:**
≤ 15 mA / A at 50 Hz
- Influence of conductor position in jaws:**
≤ 0.5% of output signal at 50/60 Hz
- Influence of frequency ⁽²⁾:**
- 2 A calibre:
< 10 % of output signal from 40 Hz .. 10 kHz
- 200 A calibre:
< 5 % of output signal from 40 Hz .. 1 kHz**
< 15 % of output signal from 1 kHz .. 10 kHz
** add 10 % error if 100 A < I_{Primary} < 200 A
- Influence of crest factor:**
< 5 % of output signal for a crest factor
< 5 with current < 280 A_{RMS}

Mechanical specifications

- Operating temperature:**
-10°C to +55°C
- Storage temperature:**
-40°C to +70°C
- Influence of temperature:**
≤ 0.20 % of output signal per 10 °K
- Relative humidity for operation:**
0 to 85 % RH with a linear decrease above 35 °C
- Influence of relative humidity:**
< 0.2 % of output signal from 10 % to 85 % RH
- Operating altitude:**
0 to 2,000 m
- Max. jaw opening:**
20 mm
- Clamping capacity:**
Cable: Ø max 20 mm
Busbar: 1 busbar of 20 x 5 mm
- Casing protection rating:**
IP40 (IEC 529)
- Drop test:**
1 m (IEC 68-2-32)
- Shock resistance:**
100 g (IEC 68-2-27)
- Vibration resistance:**
10 / 55/10 Hz, 0.15 mm (IEC 68-2-6)

Self-extinguishing capability:

Casing: UL94 V2
Jaws: UL94 V0

Dimensions:

135 x 51 x 30 mm

Mass:

180 g

Colours:

Dark grey case with red jaws

Output:

1.5 m two-wire lead with double or reinforced insulation terminated by 2 elbowed male safety plugs (4 mm)

Safety specifications

Electrical safety:

Instrument with double insulation or reinforced insulation between the primary, the secondary and the grippable part located under the guard as per IEC 1010-1 & IEC 1010-2-032

- 600 V category III, pollution degree 2
- 300 V category IV, pollution degree 2

Electromagnetic compatibility (EMC):

EN 50081-1: class B

EN 50082-2:

- Electrostatic discharge: IEC 1000-4-2
- Radiated field: IEC 1000-4-3
- Fast transients: IEC 1000-4-4
- Magnetic field at 50/60Hz: IEC 1000-4-8

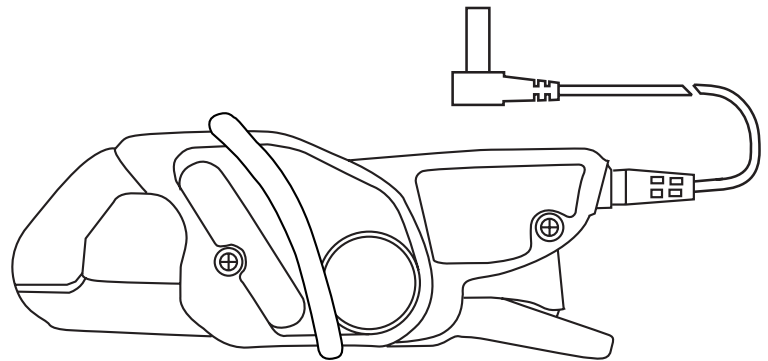

(1) Conditions of reference: 23 °C ± 3 °K, 20 % to 75 % RH, sinusoidal signal with frequency of 48Hz to 65 Hz, external magnetic field < 40 A/m, no DC components, no external conductor with circulating current, conductor centred for measurement, load impedance > 1 MΩ.

(2) Out of reference domain

To order	Reference
AC current clamp model MN73 with operating manual	P01120421

CURRENT CLAMPS FOR AC CURRENT

Models MN88 and MN89

Current	200 A AC
Output	100 mV DC / A

Description

These clamps produce a DC voltage output which is very useful for multimeters whose sensitivity in V or A is too weak.

Electrical specifications

- Current range:**
0.5 A AC .. 240 A AC
- Output signal:**
100 mV DC / A (24 V for 240 A AC)
- Accuracy and phase shift ⁽¹⁾:**

Primary current:	0.5 A .. 10 A	10 A .. 40 A	40 A .. 100 A	100 A .. 240 A
Accuracy in % of output signal	≤ 5 % + 50 mV	≤ 3 % + 50 mV	≤ 2 % + 50 mV	≤ 2 %

- Bandwidth:**
40 Hz .. 10 kHz
- Crest factor:**
3 for a current of 200 A_{RMS}
- Maximum currents:**
200 A continuous for a frequency ≤ 1 kHz (derating proportional to the inverse of frequency beyond)
- Load impedance:**
> (1 MΩ + filter RC 2s)
- Operating voltage:**
600 V_{RMS}
- Common mode voltage:**
600V category III and pollution degree 2
- Influence of adjacent conductor:**
< 15 mA / A at 50 Hz
- Influence of conductor position in jaws:**
< 0.5 % of output signal at 50 Hz
- Influence of frequency ⁽²⁾:**
< 5 % of output signal from 40 Hz .. 1 kHz
< 12 % of output signal from 1 kHz .. 10 kHz
- Influence of crest factor:**
< 3 % of output signal for a crest factor of 3 and current 200 A_{RMS}

Mechanical specifications

- Operating temperature:**
-10°C to +55°C
- Storage temperature:**
-40°C to +70°C
- Influence of temperature:**
≤ 0.15 % of output signal per 10 °K
- Relative humidity for operation:**
0 to 85 % RH with a linear decrease above 35 °C
- Influence of relative humidity:**
< 0.2 % of output signal from 10 % to 85 % RH
- Operating altitude:**
0 to 2,000 m
- Max. jaw opening:**
20 mm
- Clamping capacity:**
Cable: Ø max 20 mm
Busbar: 1 busbar of 20 x 5mm
- Casing protection rating:**
IP40 (IEC 529)
- Drop test:**
1 m (IEC 68-2-32)
- Shock resistance:**
100 g (IEC 68-2-27)
- Vibration resistance:**
10 / 55/10 Hz, 0.15 mm (IEC 68-2-6)

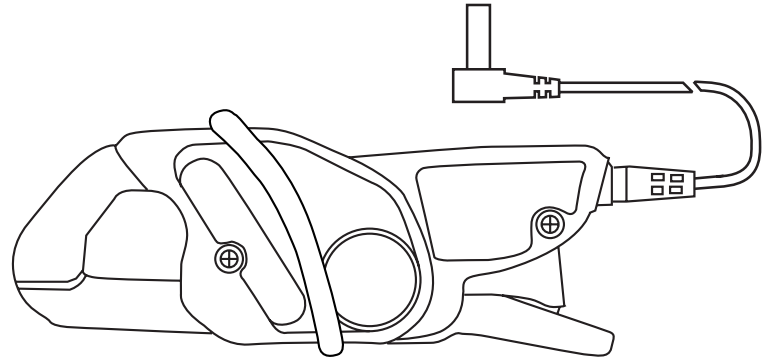

- Self-extinguishing capability:**
Casing: UL94 V2
Jaws: UL94 V0
- Dimensions:**
135 x 51 x 30 mm
- Mass:**
180 g
- Colours:**
Dark grey case with red jaws
- Output:**
MN88: Safety sockets (4mm)
MN89: 1.5 m two-wire lead with double or reinforced insulation terminated by 2 elbowed male safety plugs (4 mm)

Safety specifications

- Electrical safety:**
Instrument with double insulation or reinforced insulation between the primary, the secondary and the grippable part located under the guard as per IEC 1010-1 & IEC 1010-2-032
 - 600 V category III, pollution degree 2
 - 300 V category IV, pollution degree 2
- Electromagnetic compatibility (EMC):** : EN 50081-1: class B
EN 50082-2:
 - Electrostatic discharge: IEC 1000-4-2
 - Radiated field: IEC 1000-4-3
 - Fast transients: IEC 1000-4-4
 - Magnetic field at 50/60Hz: IEC 1000-4-8

(1) Conditions of reference: 23 °C ± 3 °K, 20 to 70 % RH, sinusoidal signal with frequency of 48 Hz to 65 Hz, external magnetic field < 40 A/m, no DC components, no external conductor with circulating current, conductor centred for measurement, load impedance > 1 MΩ + filter RC 2s.

(2) Out of reference domain

To order	Reference
AC current clamp model MN88 with operating manual	P01120410
AC current clamp model MN89 with operating manual	P01120415

CURRENT CLAMPS FOR AC CURRENT

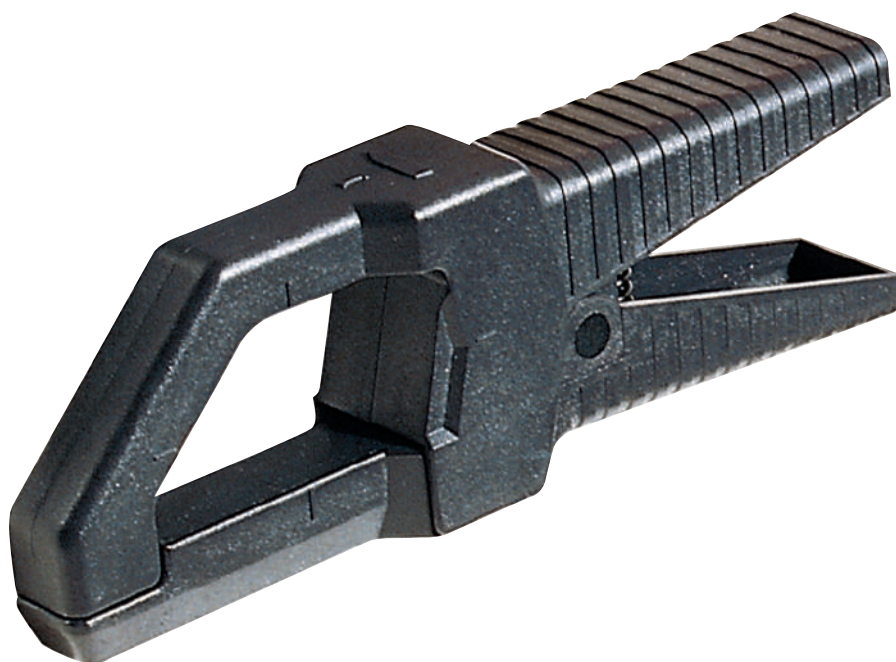

Y_N series

The Y series clamps are designed to be both rugged and versatile whilst remaining easy to use. The jaws are designed so that the clamps can be hooked onto cables and clamped onto busbars for current measurement up to 600 A AC.

There are two types of Y series clamps available:

The first acts as a current transformer (ratios of 100:1 or 1,000:1), giving an output current that may be read by a multimeter, logger or other suitable devices with appropriate current calibres.

The other kind of Y series clamp has a DC voltage output proportional to the AC current measured, allowing instruments without current calibres to measure, display and record currents on a DC voltage calibre.

There is also a model available specifically for direct use with oscilloscopes.

CURRENT CLAMPS FOR AC CURRENT

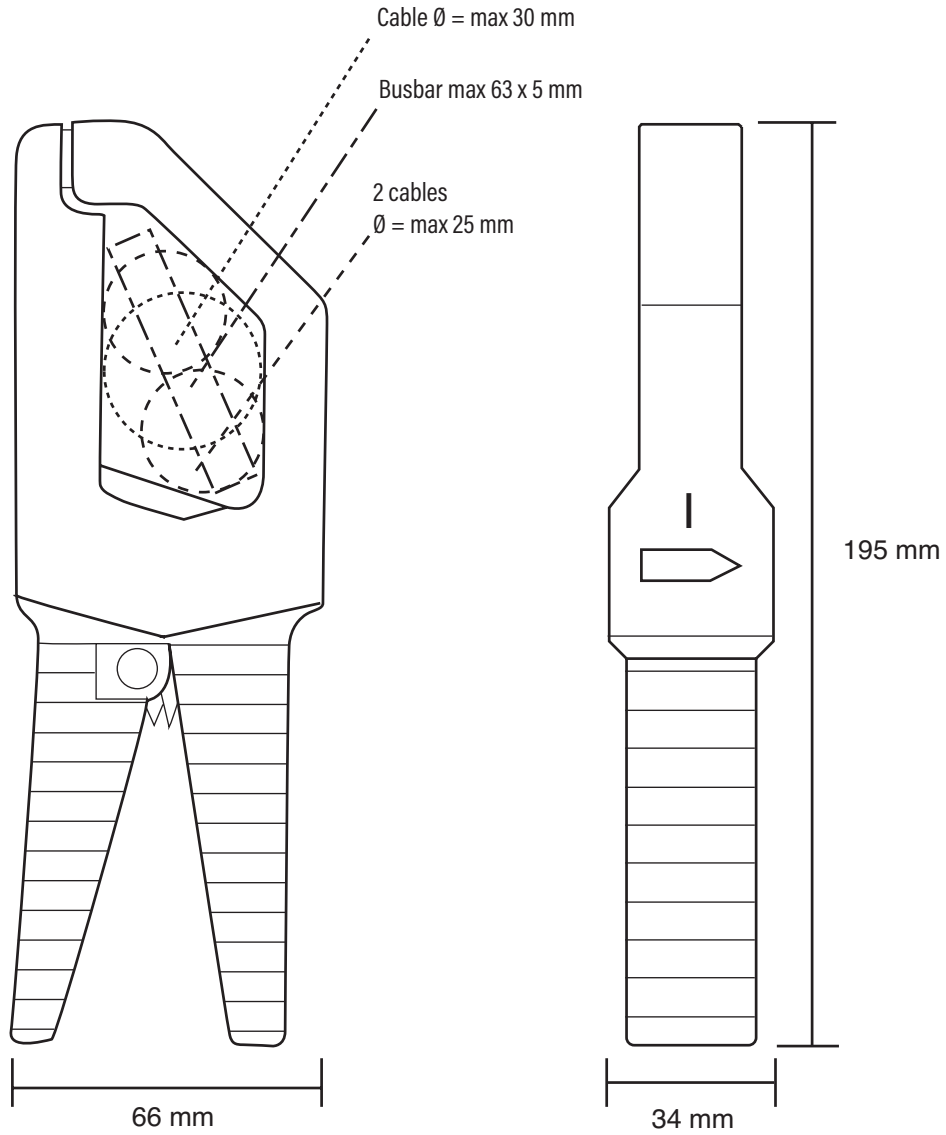

CURRENT CLAMPS FOR AC CURRENT

Model Y1N

Current	500 A AC
Ratio	1,000/1
Output	1 mA / A

Electrical specifications

- **Current range:**
4 A AC .. 600 A AC
- **Turns Ratio:**
1,000:1
- **Output signal:**
1 mA AC / A AC

- **Accuracy ⁽¹⁾:**

Primary current:	4 A	25 A	100 A	250 A	500 A	600 A ⁽²⁾
Accuracy in % of output signal	4.5% + 0.5 mA	4.5%	3.5%	3%	3%	3%
Phase shift	not specified	4°	2°	2°	2°	2°

- **Bandwidth:**
48 Hz .. 1,000 Hz
- **Load impedance:**
5 Ω max
- **Overload:**
700 A for 10 minutes
- **Maximum output voltage (secondary open):**
Limited to 10 V peak max.
- **Operating voltage:**
600 V_{RMS}
- **Common mode voltage:**
600 V_{RMS}
- **Influence of adjacent and parallel conductors:**
< 30 mA / A at 50 Hz
- **Influence of conductor position in jaws:**
± 1.5 %

Mechanical specifications

- **Operating temperature:**
-15°C to +50°C
- **Storage temperature:**
-40°C to +85°C
- **Influence of temperature:**
< 0.1 % per 10 °K
- **Relative humidity for operation:**
0 to 85 % RH with a linear decrease above 35 °C
- **Operating altitude:**
0 to 2,000 m

- **Max. jaw opening:**
33 mm
- **Clamping capacity:**
Cable: Ø max 20 mm
Busbar: 63 x 5 mm
- **Casing protection rating:**
IP20 in accordance with IEC 529
- **Drop test:**
1.5 m (IEC 68-2-32)
- **Shock resistance:**
100 g, in accordance with IEC68-2-27
- **Vibration resistance:**
10 / 55/10 Hz, 0.15 mm test in accordance with IEC68-2-6
- **Self-extinguishing capability:**
UL94 V0
- **Dimensions:**
66 x 195 x 34 mm
- **Weight:**
420 g
- **Colour:**
Dark grey
- **Output:**
Two-wire cable with reinforced insulation or double insulation, length 1.5 m, terminated by 2 insulated elbowed male banana plugs (4 mm)

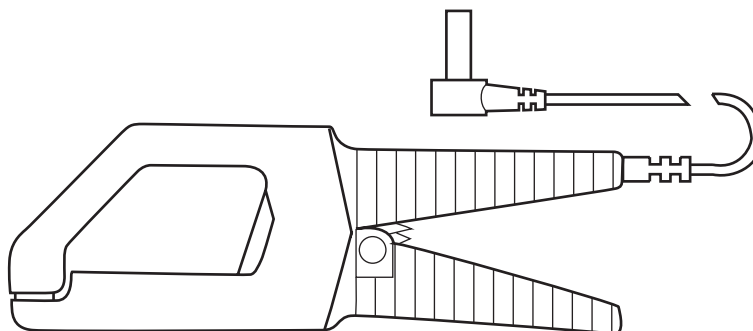

Safety specifications

- **Electrical safety:**
Double or reinforced insulation between the primary and secondary circuits and the outer casing in accordance with IEC 1010-2-032
 - 600 V category III, pollution degree 2
 - 300 V category IV, pollution degree 2
- **Electromagnetic compatibility (EMC):** :
EN 50081-1: class B
EN 50082-2:
 - Electrostatic discharge: IEC 1000-4-2
 - Radiated field: IEC 1000-4-3
 - Fast transients: IEC 1000-4-4
 - Magnetic field at 50/60Hz: IEC 1000-4-8

(1) Conditions of reference: 23 °C ± 5 °K, 20 % to 75 % RH, 48Hz to 65Hz, external magnetic field < 40 A/m, no current-carrying conductor nearby, centred test sample, load impedance 5 Ω.

(2) 700 A for 10 minutes max.

To order	Reference
AC current clamp model Y1N with operating manual	P01120001A

CURRENT CLAMPS FOR AC CURRENT

Model Y2N

Current	500 A AC
Ratio	1,000/1
Output	1 mA / A

Electrical specifications

- **Current range:**
4 A AC .. 600 A AC
- **Turns Ratio:**
1,000:1
- **Output signal:**
1 mA AC / A AC
- **Accuracy ⁽¹⁾:**
class 1 at 1.25 VA

Primary current:	4 A	25 A	100 A	250 A	500 A	600 A ⁽²⁾
Accuracy in % of output signal	3% + 0.5 mA	3%	1.5 %	1%	1%	1%
Phase shift	not specified	3°	1.5°	1°	1°	1°

- **Bandwidth:**
48 Hz .. 1,000 Hz
- **Load impedance:**
5 Ω max
- **Overload:**
700 A for 10 minutes
- **Maximum output voltage (secondary open):**
Limited to 10 V peak max.
- **Operating voltage:**
600 V_{RMS}
- **Common mode voltage:**
600 V_{RMS}
- **Influence of adjacent and parallel conductors:**
< 30 mA / A at 50 Hz
- **Influence of conductor position in jaws:**
< 1%

Mechanical specifications

- **Operating temperature:**
-15 °C .. +50 °C
- **Storage temperature:**
-40 °C .. +85 °C
- **Influence of temperature:**
< 0.1 % per 10 °K
- **Operating altitude:**
0 to 2,000 m
- **Max. jaw opening:**
33 mm
- **Clamping capacity:**
Cable: Ø max 30 mm
Busbar: 63 x 5 mm
- **Casing protection rating:**
IP20 in accordance with IEC 529
- **Drop test:**
1.5 m (IEC 68-2-32)
- **Shock resistance:**
100 g, in accordance with IEC68-2-27
- **Vibration resistance:**
10 / 55/10 Hz, 0.15 mm test in accordance with IEC68-2-6
- **Self-extinguishing capability:**
UL94 V0

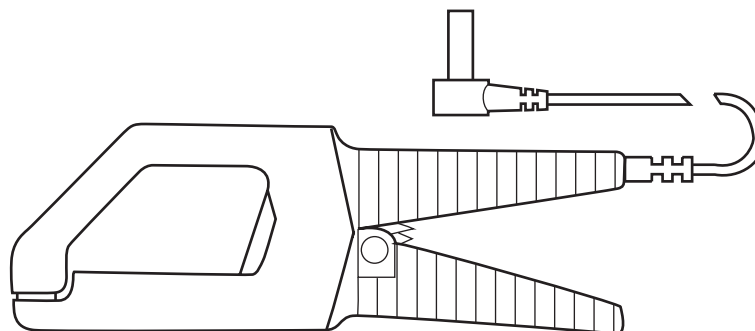

- **Dimensions:**
66 x 195 x 34 mm
- **Mass:**
420 g
- **Colour:**
Dark grey
- **Output:**
1.5 m two-wire lead with double or reinforced insulation terminated by 2 elbowed male safety plugs (4 mm)

Safety specifications

- **Electrical safety:**
Double or reinforced insulation between the primary and secondary circuits and the outer casing in accordance with IEC 1010-2-032.2-032
- 600 V category III, pollution degree 2
- 300 V category IV, pollution degree 2
- **Electromagnetic compatibility (EMC):** :
EN 50081-1: class B
EN 50082-2:
- Electrostatic discharge: IEC 1000-4-2
- Radiated field: IEC 1000-4-3
- Fast transients: IEC 1000-4-4
- Magnetic field at 50/60Hz: IEC 1000-4-8

(1) Conditions of reference: 23 °C ± 5 °K, 20 % to 75 % RH, 48Hz to 65Hz, external magnetic field < 40 A/m, no current-carrying conductor nearby, centred test sample, load impedance 5 MΩ.

(2) 700 A for 10 minutes max.

To order	Reference
AC current clamp model Y2N with operating manual	P01120028A

CURRENT CLAMPS FOR AC CURRENT

Model Y3N

Current	500 A AC
Ratio	100/1
Output	10 mA/A

Electrical specifications

- **Current range:**
4 A AC .. 600 A AC
- **Turns Ratio:**
100:1
- **Output signal:**
10 mA AC / A AC
- **Accuracy ⁽¹⁾:**
Class 3 at 2.5 VA

Primary current:	4 A	25 A	100 A	250 A	500 A	600 A ⁽²⁾
Accuracy in % of output signal	5% + 5 mA	5%	3%	3%	3%	3%
Phase shift	not specified	6°	5°	3°	3°	3°

- **Bandwidth:**
48 Hz .. 1,000 Hz
- **Load impedance:**
0.1 Ω max
- **Overload:**
700 A for 10 minutes
- **Maximum output voltage (secondary open):**
Limited to 10 V peak max.
- **Operating voltage:**
600 V_{RMS}
- **Common mode voltage:**
30 V_{RMS}
- **Influence of adjacent and parallel conductors:**
< 30 mA / A at 50 Hz
- **Influence of conductor position in jaws:**
± 1 %

Mechanical specifications

- **Operating temperature:**
-15°C to +50°C
- **Storage temperature:**
-40°C to +85°C
- **Influence of temperature:**
< 0.1 % per 10 °K
- **Relative humidity for operation:**
0 to 85 % RH with a linear decrease above 35 °C
- **Operating altitude:**
0 to 2,000 m
- **Max. jaw opening:**
33 mm
- **Clamping capacity:**
Cable: Ø max 30 mm
Busbar: 63 x 5 mm
- **Casing protection rating:**
IP20 in accordance with IEC 529
- **Drop test:**
1.5 m (IEC 68-2-32)
- **Shock resistance:**
100 g, in accordance with IEC68-2-27
- **Vibration resistance:**
10 / 55/10 Hz, 0.15 mm test in accordance with IEC68-2-6
- **Self-extinguishing capability:**
UL94 V0

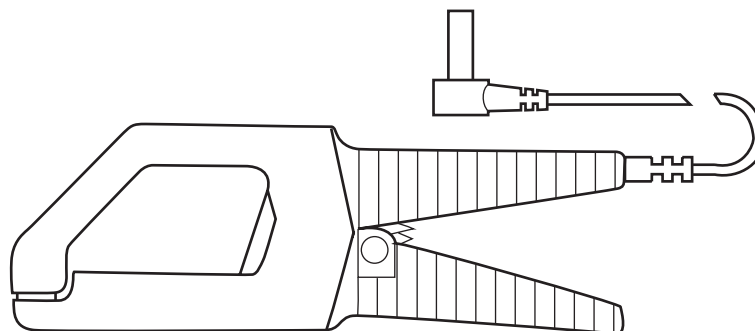

- **Dimensions:**
66 x 195 x 34 mm
- **Weight:**
420 g
- **Colour:**
Dark grey
- **Output:**
Two-wire cable with reinforced insulation or double insulation, length 1.5 m, terminated by 2 insulated elbowed male banana plugs (4 mm)

Safety specifications

- **Electrical safety:**
Double or reinforced insulation between the primary and secondary circuits and the outer casing in accordance with IEC 1010-2-032
 - 600 V category III, pollution degree 2
 - 300 V category IV, pollution degree 2
- **Electromagnetic compatibility (EMC):** :
EN 50081-1: class B
EN 50082-2:
 - Electrostatic discharge: IEC 1000-4-2
 - Radiated field: IEC 1000-4-3
 - Fast transients: IEC 1000-4-4
 - Magnetic field at 50/60Hz: IEC 1000-4-8

(1) Conditions of reference: 23 °C ± 5 °K, 20 % to 75 % RH, 48Hz to 65Hz, external magnetic field < 40 A/m, no current-carrying conductor nearby, centred test sample, load impedance 0.1 Ω.

(2) 700 A for 10 minutes max.

To order	Reference
AC current clamp model Y3N with operating manual	P01120029A

CURRENT CLAMPS FOR AC CURRENT

Model Y4N

Current	500 A AC
Output	1 mV DC / A AC

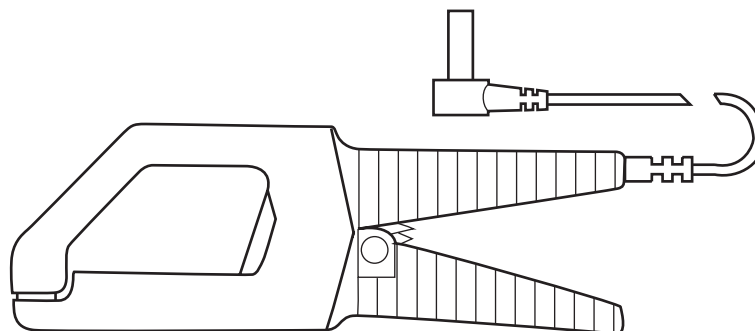

Electrical specifications

- **Current range:**
4 A AC .. 600 A AC
- **Output signal:**
1 mV DC / A AC
- **Accuracy ⁽¹⁾:**

Primary current:	2 A	25 A	100 A	250 A	500 A	600 A ⁽²⁾
Accuracy in % of output signal	5% + 0.5 mV DC	5%	2%	1%	1%	2%

- **Bandwidth:**
48 Hz .. 1,000 Hz (error: add 2 % to reference)
- **Load impedance:**
> 100 kΩ
- **Overload:**
700 A for 10 minutes
- **Operating voltage:**
600 V_{RMS}
- **Common mode voltage:**
600 V_{RMS}
- **Influence of adjacent and parallel conductors:**
< 30 mA / A at 50 Hz
- **Influence of conductor position in jaws:**
+/-1 %

Mechanical specifications

- **Operating temperature:**
-15 °C .. +50 °C
- **Storage temperature:**
-40 °C .. +85 °C
- **Influence of temperature:**
< 0.1 % per 10 °K
- **Operating altitude:**
0 to 2,000 m
- **Max. jaw opening:**
33 mm
- **Clamping capacity:**
Cable: Ø max 30 mm
Busbar: 63 x 5 mm
- **Casing protection rating:**
IP20 in accordance with IEC 529
- **Drop test:**
1.5 m (IEC 68-2-32)
- **Shock resistance:**
100 g, in accordance with IEC68-2-27
- **Vibration resistance:**
10 / 55/10 Hz, 0.15 mm test in accordance with IEC68-2-6
- **Self-extinguishing capability:**
UL94 V0

- **Dimensions:**
66 x 195 x 34 mm
- **Mass:**
420 g
- **Colour:**
Dark grey
- **Output:**
1.5 m two-wire lead with double or reinforced insulation terminated by 2 elbowed male safety plugs (4 mm)

Safety specifications

- **Electrical safety:**
Double or reinforced insulation between the primary and secondary circuits and the outer casing in accordance with IEC 1010-2-032.2-032
- 600 V category III, pollution degree 2
- 300 V category IV, pollution degree 2
- **Electromagnetic compatibility (EMC) :**
EN 50081-1: class B
EN 50082-2:
- Electrostatic discharge: IEC 1000-4-2
- Radiated field: IEC 1000-4-3
- Fast transients: IEC 1000-4-4
- Magnetic field at 50/60Hz: IEC 1000-4-8

(1) Conditions of reference: 23 °C ± 5 °K, 20 % to 75 % RH, 48Hz to 65Hz, external magnetic field < 40 A/m, no current-carrying conductor nearby, centred test sample, load impedance 10 Ω.

(2) 600 A for 10 minutes max.

To order	Reference
AC current clamp model Y4N with operating manual	P01120005A

CURRENT CLAMPS FOR AC CURRENT

Model Y7N (insulated AC current probe)

Current	1,200 A peak
Output	1 mV / A

Description

This 500 A AC clamp enables easy display and measurement of "current" curves.

It fits any oscilloscope since it has a coaxial lead with BNC plug. It produces a mV signal directly proportional to current.

Electrical specifications

- **Current range:**
1 A AC .. 500 A AC (1,200 A peak)
- **Output signal:**
1 mV AC / A AC (0.5 V for 500 A)
- **Accuracy and phase shift ⁽¹⁾:**

Primary current:	1 A .. 20 A	20 A .. 100 A	100 A .. 500 A
Accuracy in % of output signal	≤ 5% + 0.3 mV	≤ 5%	≤ 2%
Phase shift	not specified	≤ 3°	≤ 1°

- **Bandwidth:**
5 Hz .. 10 kHz (A -3 dB) (depending on current value)
- **Rise/fall time from 10 % to 90 %:**
37 μs
- **10 % delay time:**
1 μs
- **Ampere second product:**
10 A.s
- **Insertion impedance (at 400 Hz / 10 kHz)**
< 0.1 mΩ / < 3.1 mΩ
- **dV / dt:**
0.24 mV / μs (typical)
- **Maximum currents:**
500 A constant
700 A: 10 minutes operation / 30 minutes shutdown for frequency 2 kHz (limitation proportional to the inverse of one third of the frequency above that)
- **Internal load impedance:**
≤ 100 Ω / 4.7 nF
- **Influence of temperature:**
≤ 0.15 % of output signal per 10 °K
- **Influence of adjacent conductor:**
≤ 5 μV / A at 50 Hz
- **Influence of conductor position in jaws:**
≤ 1.5 % + 0.1 A AC

Mechanical specifications

- **Operating temperature:**
-25°C to +50°C
- **Storage temperature:**
-40°C to +80°C
- **Relative humidity for operation:**
0 to 85% RH with a linear decrease above 35 °C
- **Operating altitude:**
0 to 2,000 m
- **Max. jaw opening:**
33 mm
- **Clamping capacity:**
Cable: Ø max 30 mm
Busbar: 1 busbar of 63 x 5mm
- **Casing protection rating:**
IP20 (IEC 529)
- **Drop test:**
1.5 m (IEC 68-2-32)
- **Shock resistance:**
100 g / 6 ms / half-period (IEC 68-2-27)
- **Protection against impacts:**
IK04 0.5 J (EN 50102)
- **Vibration resistance:**
10 / 55/10 Hz 0.15 mm (IEC 68-2-6)
- **Self-extinguishing capability:**
UL94 V0
- **Dimensions:**
195 x 66 x 34 mm

- **Mass:**
420 g
- **Colour:**
Dark grey
- **Output:**
Coaxial cable 2 m long, terminated by an insulated BNC connector

Safety specifications

- **Electrical safety:**
Instrument with double insulation or reinforced insulation between the primary, the secondary and the grippable part located under the guard as per IEC 1010-1 & IEC 1010-2-032
 - 600 V category III, pollution degree 2
 - 300 V category IV, pollution degree 2
- **Electromagnetic compatibility (EMC) :**
EN 50081-1: class B
EN 50082-2:
 - Electrostatic discharge: IEC 1000-4-2
4 kV level 2 performance criterion B
8 kV in the air level 3 performance criterion B
 - Radiated field: IEC 1000-4-3
10 V/m performance criterion A
 - Fast transients: IEC 1000-4-4
1 kV level 2 performance criterion B
2 kV level 3 performance criterion B
 - Magnetic field at 50/60Hz:
IEC 1000-4-8 field of 400 A/m at 50 Hz: <1 A

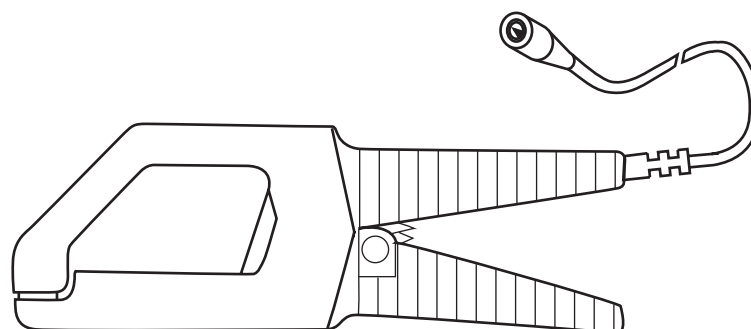

CURRENT CLAMPS FOR AC CURRENT

Model Y7N (insulated AC current probe)

Curves

Error on measurement at 50 Hz

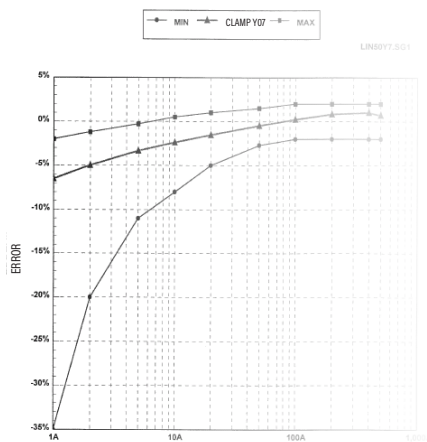

Phase shift at 50 Hz

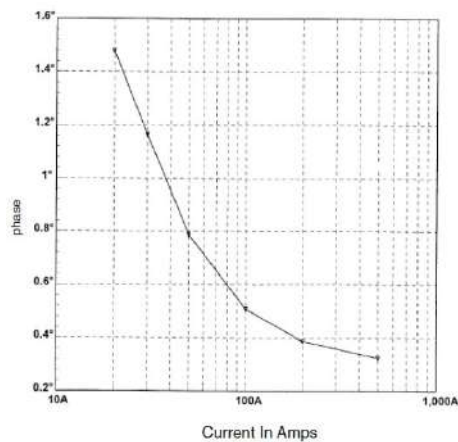

Frequency response

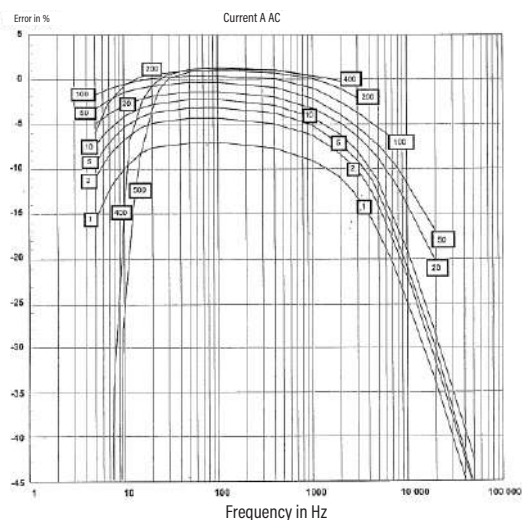

Phase shift according to frequency

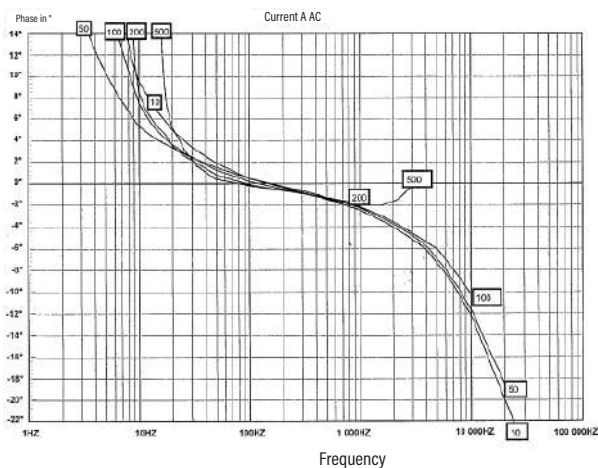

Influence of frequency and derating

Frequency Hz	5 Hz to 10 Hz	10 Hz to 20 Hz	20 Hz to 45 Hz	65 Hz to 3 kHz	3 kHz to 6 kHz	6 kHz to 10 kHz
1 A to 200 A	15 %					
> 200 A	not spec.					
1 A to 300 A		5 %				
300 A to 400 A		15 %				
400 A to 500 A		25 %				
1 A to 500 A			5 %			
1 A to 50 A				5 % + 0.4 A		
50 A to 500 A				5 %		
> 500 A				not spec.		
1 A to 100 A					15 % + 0.4 A	
> 100 A					not spec.	
1 A to 50 A						-3 dB
> 50 A						not spec.

Influence of DC current

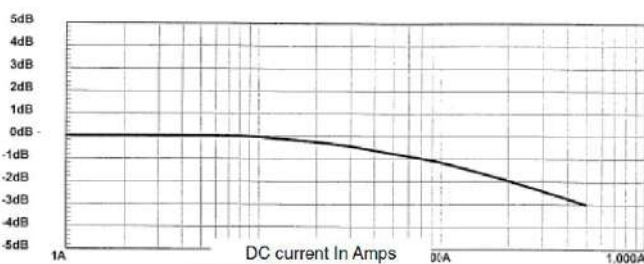

- Error in % of reading, not spec. means not specified
 - Do not exceed 500 A for measurement with constant operation, and for the derating, use the formula $500 / F$ (kHz) to calculate the maximum current in A AC, in constant use, depending on the frequency in kHz.

CURRENT CLAMPS FOR AC CURRENT

Model Y7N (insulated AC current probe)

Response to a square signal

5 A at 10 Hz

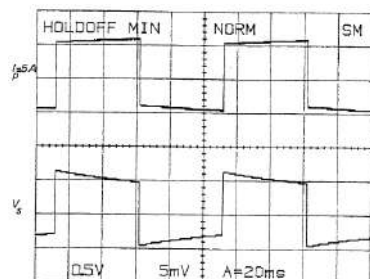

5 A at 50 Hz

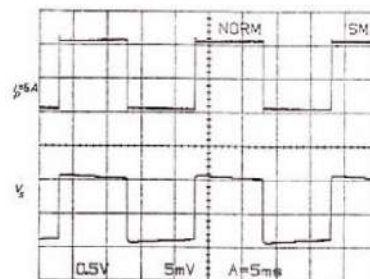

5 A at 500 Hz

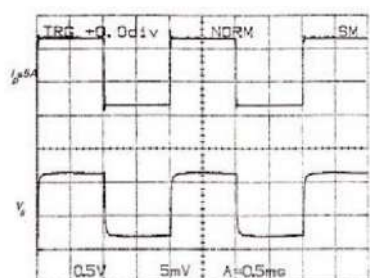

5 A at 4 kHz

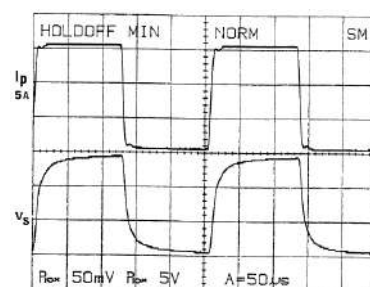

Response to a step

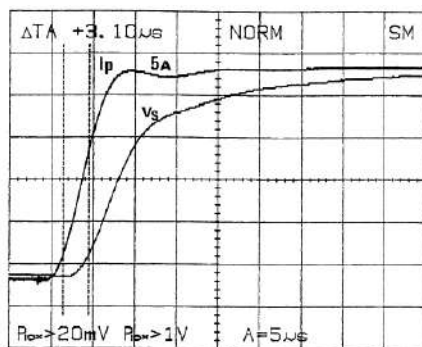

(1) Conditions of reference: 23 °C ± 3 °K, 20 % to 75 % RH, sinusoidal signal with frequency of 48 Hz at 1 kHz, external magnetic field < 40 A/m, no DC components, no external conductor with circulating current, conductor centred for measurement, load impedance > 1 MΩ / < 100 pF.

To order	Reference
AC current clamp model Y7N for oscilloscope with operating manual	P01120075

NOTES

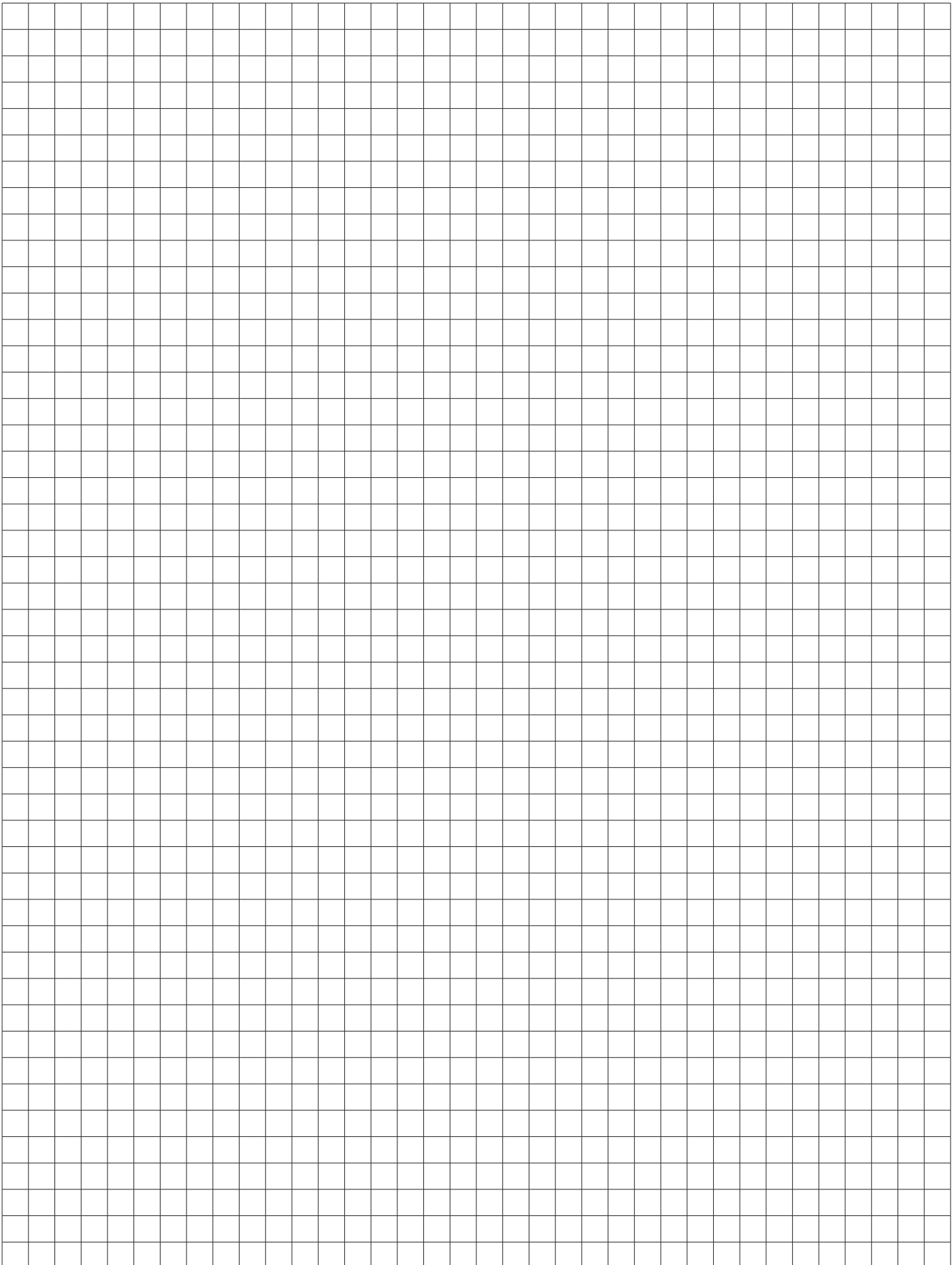

CURRENT CLAMPS FOR AC CURRENT



"C100" series

The "C100" series is a range of thirteen transformer clamps with all the advantages of our old "C30" series clamps whilst incorporating considerable improvements, particularly in the field of safety, ergonomics and performance:

1,000 A measurement, excellent metrology, high accuracy, high level of linearity, symmetrical coil windings for minimum phase shift, pendular adjusting system for magnetic elements, maximum conductor diameter \varnothing 52 mm and also some models with μ -metal core specially made for wattmeter use.

Innovative design: excellent ergonomics, handle with finger grips, assisted opening system for jaws (patented system), IEC 1010 600 V CAT III safety (industry and services), antislip protection, conductor antipinching system...

All this technology and manufacturing quality has been combined to provide the best measurement possible without any complications.

A "C100" series clamp is compatible with any instrument (multimeter, wattmeter, recorder, oscilloscope...) for safe measurement of AC currents without shutting down the installation.

CURRENT CLAMPS FOR AC CURRENT

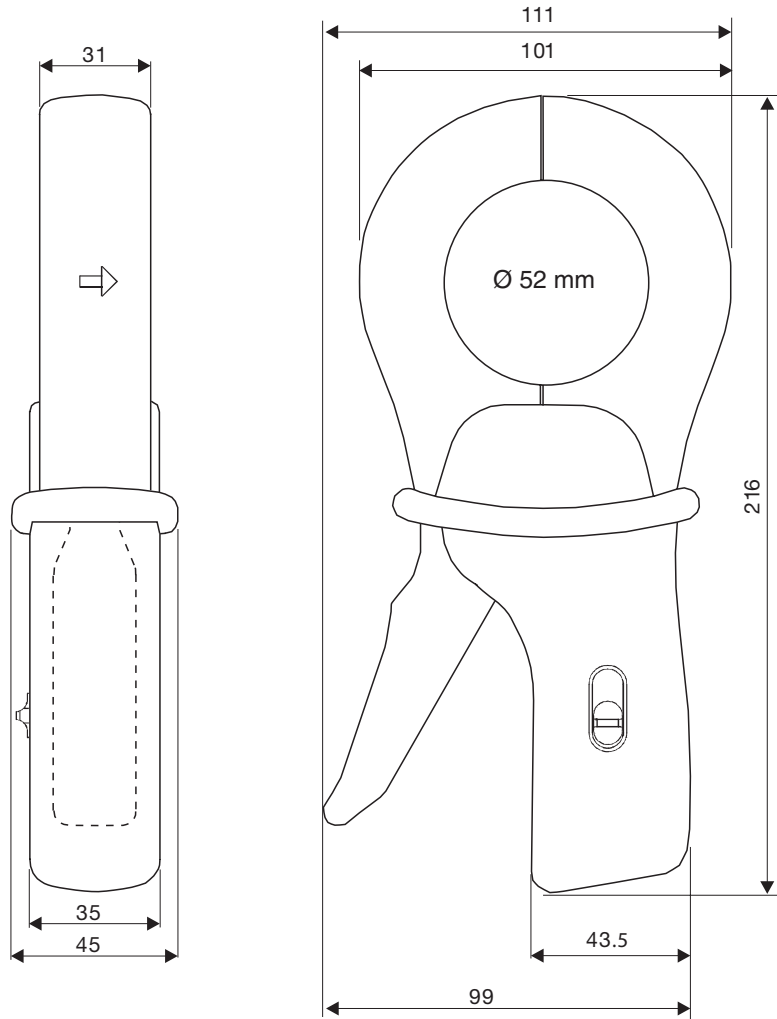

CURRENT CLAMPS FOR AC CURRENT

Model C100

Current	1,000 A
Ratio	1,000/1
Output	1 mA / A

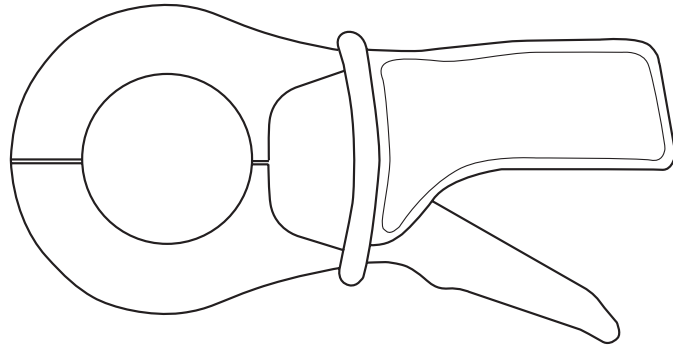

Electrical specifications

- Current range:**
0.1 A AC .. 1,200 A AC
- Turns Ratio:**
1,000:1
- Output signal:**
1 mA AC / A AC (1 A for 1,000 A)
- Accuracy and phase shift ⁽¹⁾:**

Primary current:	0.1 A .. 10 A	10 A	50 A ⁽²⁾	200 A ⁽²⁾	1,000 A ⁽²⁾	1,200 A ⁽²⁾
Accuracy in % of output signal	≤ 3 % + 0.1 mA	≤ 3 %	≤ 1.5 %	≤ 0.75 %	≤ 0.5 %	≤ 0.5 %
Phase shift	not specified	≤ 3 °	≤ 1.5 °	≤ 0.75 °	≤ 0.5 °	≤ 0.5 °

- Bandwidth:**
30 Hz .. 10 kHz (-3 dB)
- Crest factor:**
≤ 6 for a current ≤ 3,000 A peak (500 A_{RMS})
- Maximum currents:**
1,000 A continuous for a frequency ≤ 1 kHz (limitation proportional to the inverse of frequency beyond)
1,200 A for 40 minutes max (interval between measurements > 20 minutes)
- Load impedance:**
≤ 15 Ω
- Operating voltage:**
600 V_{RMS}
- Common mode voltage:**
600V category III and pollution degree 2
- Influence of adjacent conductor:**
≤ 1 mA / A at 50 Hz
- Influence of conductor position in jaws:**
≤ 0.1 % of output signal for frequencies ≤ 400 Hz
- Load influence:**
From 5 Ω to 15 Ω
< 0.5 % on measurement
< 0.5 ° on phase
- Influence of frequency ⁽³⁾:**
< 1 % of output signal from 30 Hz .. 48Hz
< 0.5 % of output signal from 65 Hz .. 1kHz
< 1 % of output signal from 1 kHz .. 5 kHz
- Influence of crest factor:**
< 1 % of output signal for crest factor ≤ 6 with current
≤ 3,000 A peak (500 A_{RMS})
- Influence of DC current superimposed on rated current:**
< 1 % of output signal for a current ≤ 30 A DC

Mechanical specifications

- Operating temperature:**
-10°C to +50°C
- Storage temperature:**
-40°C to +70°C
- Influence of temperature:**
≤ 0.1 % of output signal per 10 °K
- Relative humidity for operation:**
0 to 85 % RH with a linear decrease above 35 °C
- Influence of relative humidity:**
< 0.1 % of output signal from 10 % to 85 % RH
- Operating altitude:**
0 to 2,000 m
- Max. jaw opening:**
52mm
patented progressive opening system
- Clamping capacity:**
Cable: Ø max 52 mm
Busbar: 1 busbar of 50 x 5 mm / 4 busbars of 30 x 5 mm
- Casing protection rating:**
IP40 (IEC 529)
- Drop test:**
1 m (IEC 68-2-32)
- Shock resistance:**
100 g, in accordance with IEC68-2-27
- Vibration resistance:**
5/15 Hz 1.5 mm
15/25 Hz 1 mm
25/55 Hz 0.25 mm (IEC68-2-6)

- Self-extinguishing capability:**
Casing and jaws: UL94 V0
- Dimensions:**
216 x 111 x 45 mm
- Weight:**
550 g
- Colour:**
Dark grey case with red jaws
- Output:**
Safety sockets (4mm)

Safety specifications

- Electrical safety:**
Double or reinforced insulation between the primary and secondary circuits and the outer casing in accordance with IEC 1010-2-032
- 600 V category III, pollution degree 2
- 300 V category IV, pollution degree 2
- Electromagnetic compatibility (EMC): :**
EN 50081-1: class B
EN 50082-2:
- Electrostatic discharge: IEC 1000-4-2
- Radiated field: IEC 1000-4-3
- Fast transients: IEC 1000-4-4
- Magnetic field at 50/60Hz: IEC 1000-4-8

(1) Conditions of reference: 23 °C ± 3 °K, 20 % to 75 % RH, signal sinus, frequency of 48 Hz to 65 Hz, distortion factor < 1 %, no DC components, external magnetic field < 40 A/m, no AC magnetic field, conductor centred for measurement, load impedance 5 Ω (5 VA)

(2) Accuracy class in accordance with IEC185: 5 VA - class 0.5 - 48 Hz .. 65 Hz

(3) Out of frequency domain

To order	Reference
AC current clamp model C100 with operating manual	P01120301

CURRENT CLAMPS FOR AC CURRENT

Models C102 and C103

Current	1,000 A
Ratio	1,000/1
Output	1 mA / A

Description

An electronic voltage-limiting system protects output of clamp when operating, if the secondary circuit is opened.

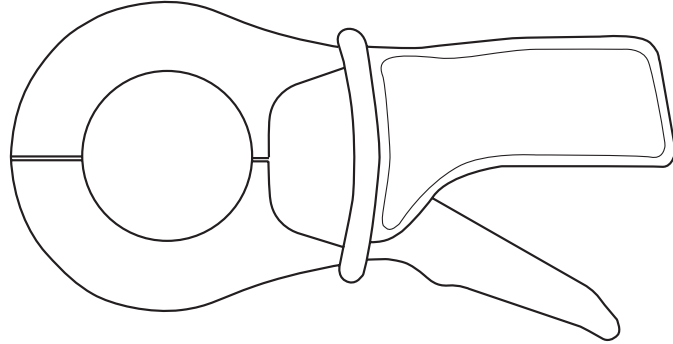

Electrical specifications

- Current range:**
0.1 A AC .. 1,200 A AC
- Turns Ratio:**
1,000:1
- Output signal:**
1 mA AC / A AC (1 A for 1,000 A)
- Accuracy and phase shift ⁽¹⁾:**

Primary current:	0.1 A .. 10 A	10 A	50 A ⁽²⁾	200 A ⁽²⁾	1,000 A ⁽²⁾	1,200 A ⁽²⁾
Accuracy in % of output signal	≤ 3 % + 0.1 mA	≤ 3 %	≤ 1.5 %	≤ 0.75 %	≤ 0.5 %	≤ 0.5 %
Phase shift	not specified	≤ 3 °	≤ 1.5 °	≤ 0.75 °	≤ 0.5 °	≤ 0.5 °

- Bandwidth:**
30 Hz .. 10 kHz (-3 dB)
- Crest factor:**
≤ 6 for a current ≤ 3,000 A peak (500 A_{RMS})
- Maximum currents:**
1,000 A continuous for a frequency ≤ 1 kHz (limitation proportional to the inverse of frequency beyond)
1,200 A for 40 minutes max (interval between measurements > 20 minutes)
- Load impedance:**
≤ 15 Ω
- Max. voltage output:**
Limited to 30 V peak max.
- Operating voltage:**
600 V_{RMS}
- Common mode voltage:**
600V category III and pollution degree 2
- Influence of adjacent conductor:**
≤ 1 mA / A at 50 Hz
- Influence of conductor position in jaws:**
≤ 0.1 % of output signal for frequencies ≤ 400 Hz
- Load influence:**
From 5 Ω to 15 Ω
< 0.5 % on measurement
< 0.5 ° on phase
- Influence of frequency ⁽³⁾:**
< 1 % of output signal from 30 Hz .. 48 Hz
< 0.5 % of output signal from 65 Hz .. 1 kHz
< 1 % of output signal from 1 kHz .. 5 kHz

- Influence of crest factor:**
< 1 % of output signal for a crest factor
≤ 6 with current ≤ 3,000 A peak (500 A_{RMS})
- Influence of DC current superimposed on rated current:**
< 1 % of output signal for a current
≤ 30 A DC

Mechanical specifications

- Operating temperature:**
-10°C to +50°C
- Storage temperature:**
-40°C to +70°C
- Influence of temperature:**
≤ 0.1 % of output signal per 10 °K
- Relative humidity for operation:**
0 to 85 % RH with a linear decrease above 35 °C
- Influence of relative humidity:**
< 0.1 % of output signal from 10 % to 85 % RH
- Operating altitude:**
0 to 2,000 m
- Max. jaw opening:**
53 mm, patented progressive opening system
- Clamping capacity:**
Cable: Ø max 52 mm
Busbar: 1 busbar of 50 x 5 mm / 4 busbars of 30 x 5 mm
- Casing protection rating:**
IP40 (IEC 529)
- Drop test:**
1 m (IEC 68-2-32)

- Shock resistance:**
100 g (IEC 68-2-27)
- Vibration resistance:**
5/15 Hz 1.5 mm -15/25 Hz 1 mm - 25/55 Hz
0.25 mm (IEC68-2-6)
- Self-extinguishing capability:**
Casing and jaws: UL94 V0
- Dimensions:**
216 x 111 x 45 mm
- Mass:**
550 g
- Colours:**
Dark grey case with red jaws
- Output:**
C102: Safety sockets (4 mm)
C103: two-wire cable with reinforced insulation or double insulation, length 1.5 m, terminated by 2 insulated elbowed male banana plugs (4 mm)

Safety specifications

- Electrical safety:**
Instrument with double insulation or reinforced insulation between the primary, the secondary and the grippable part located under the guard as per IEC 1010-1 & IEC 1010-2-032
- 600 V category III, pollution degree 2
- 300 V category IV, pollution degree 2
- Electromagnetic compatibility (EMC) :**
EN 50081-1: class B
EN 50082-2:
- Electrostatic discharge: IEC 1000-4-2
- Radiated field: IEC 1000-4-3
- Fast transients: IEC 1000-4-4
- Magnetic field at 50 Hz: IEC 1000-4-8

(1) Conditions of reference: 23 °C ± 3 °K, 20 % to 75 % RH, signal sinus, frequency of 48 Hz to 65 Hz, distortion factor < 1 %, no DC components, external magnetic field < 40 A/m, no AC magnetic field, conductor centred for measurement, load impedance 5 Ω (5 VA).

(2) Accuracy class in accordance with IEC185: 5 VA - class 0.5 - 48 .. 65 Hz.

(3) Out of reference domain.

To order	Reference
AC current clamp model C102 with operating manual	P01120302
AC current clamp model C103 with operating manual	P01120303

CURRENT CLAMPS FOR AC CURRENT

Models C106 and C107

Current	1,000 A
Output	1 mV / A

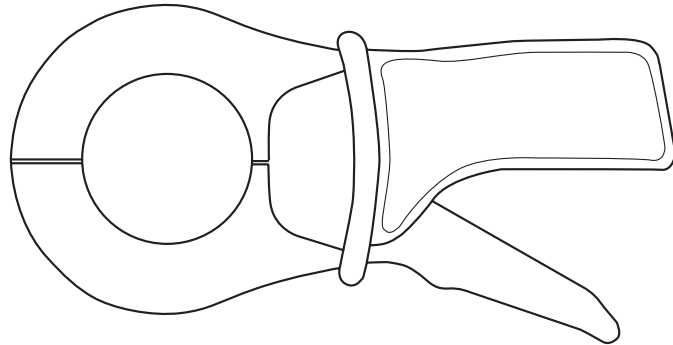

Electrical specifications

- Current range:**
0.1 A AC .. 1,200 A AC
- Output signal:**
1 mV AC / A AC (1 V for 1,000 A)
- Accuracy and phase shift ⁽¹⁾:**

Primary current:	0.1 A .. 10 A	10 A	50 A	200 A	1,000 A	1,200 A
Accuracy in % of output signal	≤ 3 % + 0.1 mV	≤ 3 %	≤ 1.5 %	≤ 0.75 %	≤ 0.5 %	≤ 0.5 %
Phase shift	not specified	≤ 3 °	≤ 1.5 °	≤ 0.75 °	≤ 0.5 °	≤ 0.5 °

- Bandwidth:**
30 Hz .. 10 kHz
- Crest factor:**
≤ 6 for a current ≤ 3,000 A peak (500 A_{RMS})
- Maximum currents:**
1,000 A continuous for a frequency ≤ 1 kHz (limitation proportional to the inverse of frequency beyond)
1,200 A for 40 minutes max (interval between measurements > 20 minutes)
- Output impedance:**
1 Ω ± 1 %
- Load impedance:**
≥ 1 MΩ and ≤ 100 pF
- Operating voltage:**
600 V_{RMS}
- Common mode voltage:**
600V category III and pollution degree 2
- Influence of adjacent conductor:**
≤ 1 mA / A at 50 Hz
- Influence of conductor position in jaws:**
≤ 0.1 % of output signal for frequencies ≤ 400 Hz
- Load influence:**
On receiver, for an input impedance of 100Ω:
≤ 1 % on measurement, no measurement on phase
On receiver, for an input impedance of 1 kΩ:
≤ 0.1 % on measurement, no measurement on phase
- Influence of frequency ⁽²⁾:**
< 1 % of output signal from 30 Hz .. 48Hz
< 0.5 % of output signal from 65 Hz .. 1kHz
< 1 % of output signal from 1 kHz .. 5 kHz
- Influence of crest factor:**
< 1 % of output signal for crest factor ≤ 6 with current
≤ 3,000 A peak (500 A_{RMS})
- Influence of DC current superimposed on rated current:**
< 1 % of output signal for a current ≤ 30 A DC

Mechanical specifications

- Operating temperature:**
-15°C to +50°C
- Storage temperature:**
-40°C to +70°C
- Influence of temperature:**
≤ 0.1 % of output signal per 10 °K
- Relative humidity for operation:**
0 to 85 % RH with a linear decrease above 35°C
- Influence of relative humidity:**
< 0.1 % of output signal from 10 % to 85 % RH
- Operating altitude:**
0 to 2,000 m
- Max. jaw opening:**
53mm
patented progressive opening system
- Clamping capacity:**
Cable: Ø max 52 mm
Busbar: 1 busbar of 50 x 5 mm / 4 busbars of 30 x 5 mm
- Casing protection rating:**
IP40 (IEC 529)
- Drop test:**
1 m (IEC 68-2-32)
- Shock resistance:**
100 g (IEC 68-2-27)
- Vibration resistance:**
5/15 Hz 1.5 mm
15/25 Hz 1 mm
25/55 Hz 0.25 mm (IEC68-2-6)
- Self-extinguishing capability:**
Casing and jaws: UL94 V0
- Dimensions:**
216 x 111 x 45 mm

- Weight:**
550 g
- Colour:**
Dark grey case with red jaws
- Output:**
C106: safety sockets (4 mm)
C107: Two-wire cable with reinforced insulation or double insulation, length 1.5 m, terminated by 2 insulated elbowed male banana plugs (4mm)

Safety specifications

- Electrical safety:**
Double or reinforced insulation between the primary and secondary circuits and the outer casing in accordance with IEC 1010-2-032
 - 600 V category III, pollution degree 2
 - 300 V category IV, pollution degree 2
- Electromagnetic compatibility (EMC):** :
EN 50081-1: class B
EN 50082-2:
 - Electrostatic discharge: IEC 1000-4-2
 - Radiated field: IEC 1000-4-3
 - Fast transients: IEC 1000-4-4
 - Magnetic field at 50/60Hz: IEC 1000-4-8

(1) Conditions of reference: 23 °C ± 3 °K, 20 % to 75 % RH, signal sinus, frequency of 48 Hz to 65 Hz, distortion factor < 1 %, no DC components, external magnetic field < 40 A/m, no AC magnetic field, conductor centred for measurement.

(2) Out of reference domain.

To order	Reference
AC current clamp model C106 with operating manual	P01120304
AC current clamp model C107 with operating manual	P01120305

CURRENT CLAMPS FOR AC CURRENT

Models C112 and C113

Current	1,000 A
Ratio	1,000/1
Output	1 mA / A

Description

Thanks to their excellent technical performance (phase shift and linearity), these μ -metal core clamps are highly recommended for wattmeter use.

These clamps are protected at output against overvoltages.

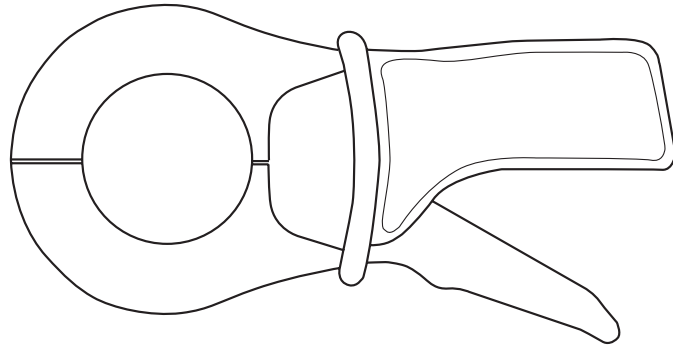

Electrical specifications

- Current range:**
0.001 A AC .. 1,200 A AC
- Turns Ratio:**
1,000:1
- Output signal:**
1 mA AC / A AC (1 A for 1,000 A)
- Accuracy and phase shift ⁽¹⁾:**

Primary current:	1 mA .. 100 mA	0.1 A .. 1 A	1 A .. 10 A	10 A .. 100 A	100 A .. 1,200 A
Accuracy in % of output signal	$\leq 3\% + 5 \mu\text{A}$	$\leq 2\% + 3 \mu\text{A}$	$\leq 1\%$	$\leq 0.5\%$	$\leq 0.3\%$
Phase shift	not specified	not specified	$\leq 2^\circ$	$\leq 1^\circ$	$\leq 0.7^\circ$

- Bandwidth:**
30 Hz .. 10 kHz
- Crest factor:**
 ≤ 6 for a current $\leq 2,000$ A peak (300 A_{RMS})
- Maximum currents:**
1,000 A continuous for a frequency ≤ 1 kHz (limitation proportional to the inverse of frequency beyond)
1,200 A for 40 minutes max (interval between measurements > 20 minutes)
- Load impedance:**
 $\leq 1 \Omega$
- Max. voltage output:**
Limited to 30 V peak max.
- Operating voltage:**
600 V_{RMS}
- Common mode voltage:**
600V category III and pollution degree 2
- Influence of adjacent conductor:**
 ≤ 0.5 mA / A at 50 Hz
- Influence of conductor position in jaws:**
 $\leq 0.1\%$ of output signal for frequencies ≤ 400 Hz
- Load influence:**
From 1Ω to 5Ω
 $< 0.1\%$ on measurement
 $< 0.2^\circ$ on phase
- Influence of frequency ⁽²⁾:**
 $< 0.5\%$ of output signal from 30 Hz .. 48Hz
 $< 1\%$ of output signal from 65 Hz .. 1kHz
 $< 2\%$ of output signal from 1 kHz .. 5 kHz

- Influence of crest factor:**
 $< 1\%$ of output signal for a crest factor ≤ 6 with current $\leq 2,000$ A peak (300 A_{RMS})
- Influence of DC current superimposed on rated current:**
 $< 1\%$ of output signal for a current ≤ 15 A DC

Mechanical specifications

- Operating temperature:**
 -10°C to $+50^\circ\text{C}$
- Storage temperature:**
 -40°C to $+70^\circ\text{C}$
- Influence of temperature:**
 $\leq 0.2\%$ of output signal per 10°K
- Relative humidity for operation:**
0 to 85% RH with a linear decrease above 35°C
- Influence of relative humidity:**
 $< 0.1\%$ of output signal from 10% to 85% RH
- Operating altitude:**
0 to 2,000 m
- Max. jaw opening:**
53 mm, patented progressive opening system
- Clamping capacity:**
Cable: \emptyset max 52 mm
Busbar: 1 busbar of 50×5 mm / 4 busbars of 30×5 mm
- Casing protection rating:**
IP40 (IEC 529)

- Drop test:**
1 m (IEC 68-2-32)
- Shock resistance:**
100 g (IEC 68-2-27)
- Vibration resistance:**
5/15 Hz 1.5 mm, 15/25 Hz 1 mm, 25/55 Hz 0.25 mm (IEC68-2-6)
- Self-extinguishing capability:**
Casing and jaws: UL94 V0
- Dimensions:**
216 x 111 x 45 mm
- Mass:**
550 g
- Colours:**
Dark grey case with red jaws
- Output:**
C112: Safety sockets (4 mm)
C113: two-wire cable with reinforced insulation or double insulation, length 1.5 m, terminated by 2 insulated elbowed male banana plugs (4 mm)

Safety specifications

- Electrical safety:**
Instrument with double insulation or reinforced insulation between the primary, the secondary and the grippable part located under the guard as per IEC 1010-1 & IEC 1010-2-032
- 600 V category III, pollution degree 2
- 300 V category IV, pollution degree 2
- Electromagnetic compatibility (EMC):** :
EN 50081-1: class B
EN 50082-2:
- Electrostatic discharge: IEC 1000-4-2
- Radiated field: IEC 1000-4-3
- Fast transients: IEC 1000-4-4
- Magnetic field at 50 Hz: IEC 1000-4-8

(1) Conditions of reference: $23^\circ\text{C} \pm 3^\circ\text{K}$, 20% to 75% RH, signal sinus, frequency of 48 Hz to 65 Hz, distortion factor $< 1\%$, no DC components, external magnetic field < 40 A/m, no AC magnetic field, conductor centred for measurement, load impedance 1Ω (1 VA)

(2) Out of reference domain

To order	Reference
AC current clamp model C112 with operating manual	P01120314
AC current clamp model C113 with operating manual	P01120315

CURRENT CLAMPS FOR AC CURRENT

Models C116 and C117

Current	1,000 A
Output	1 mV / A

Description

Thanks to their excellent technical performance (phase shift and linearity), these μ -metal core clamps are highly recommended for wattmeter use.

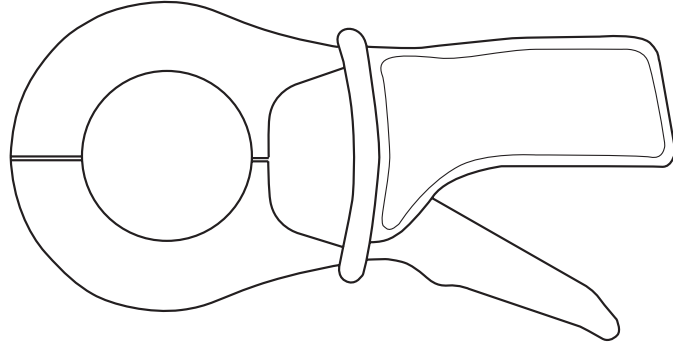

Electrical specifications

- Current range:**
0.001 A AC .. 1,200 A AC
- Output signal:**
1 mV AC / A AC (1 V for 1,000 A)
- Accuracy and phase shift ⁽¹⁾:**

Primary current:	1 mA .. 100 mA	0.1 A .. 1 A	1 A .. 10 A	10 A .. 100 A	100 A .. 1,200 A
Accuracy in % of output signal	$\leq 3\% + 5 \mu\text{A}$	$\leq 2\% + 3 \mu\text{A}$	$\leq 1\%$	$\leq 0.5\%$	$\leq 0.3\%$
Phase shift	not specified	not specified	$\leq 2^\circ$	$\leq 1^\circ$	$\leq 0.7^\circ$

- Bandwidth:**
30 Hz .. 10 kHz
- Crest factor:**
 ≤ 6 for a current $\leq 2,000$ A peak (300 A_{RMS})
- Maximum currents:**
1,000 A continuous for a frequency ≤ 1 kHz (limitation proportional to the inverse of frequency beyond)
1,200 A for 40 minutes max (interval between measurements > 20 minutes)
- Output impedance:**
 $1 \Omega \pm 1\%$
- Load impedance:**
 $\geq 1 \text{ M}\Omega$ and $\leq 100 \text{ pF}$
- Max. voltage output:**
Limited to 30 V peak max.
- Operating voltage:**
600 V_{RMS}
- Common mode voltage:**
600V category III and pollution degree 2
- Influence of adjacent conductor:**
 $\leq 0.5 \text{ mA} / \text{A}$ at 50 Hz
- Influence of conductor position in jaws:**
 $\leq 0.1\%$ of output signal for frequencies ≤ 400 Hz
- Load influence:**
On receiver, for an input impedance of 100 Ω : $\leq 1\%$ on measurement, no measurement on phase.
On receiver, for an input impedance of 1 k Ω : $\leq 0.1\%$ on measurement, no measurement on phase.

- Influence of frequency ⁽²⁾:**
 $< 0.5\%$ of output signal from 30 Hz .. 48Hz
 $< 1\%$ of output signal from 65 Hz .. 1kHz
 $< 2\%$ of output signal from 1 kHz .. 5 kHz
- Influence of crest factor:**
 $< 1\%$ of output signal for a crest factor ≤ 6 with current $\leq 2,000$ A peak
- Influence of DC current superimposed on rated current:**
 $< 1\%$ of output signal for a current ≤ 15 A DC

Mechanical specifications

- Operating temperature:**
-10°C to +50°C
- Storage temperature:**
-40°C to +70°C
- Influence of temperature:**
 $\leq 0.2\%$ of output signal per 10 °K
- Relative humidity for operation:**
0 to 85% RH with a linear decrease above 35 °C
- Influence of relative humidity:**
 $< 0.1\%$ of output signal from 10% to 85% RH
- Operating altitude:**
0 to 2,000 m
- Max. jaw opening:**
53 mm, patented progressive opening system
- Clamping capacity:**
Cable: \emptyset max 52 mm
Busbar: 1 busbar of 50 x 5 mm / 4 busbars of 30 x 5 mm

- Casing protection rating:**
IP40 (IEC 529)
- Drop test:**
1 m (IEC 68-2-32)
- Shock resistance:**
100 g (IEC 68-2-27)
- Vibration resistance:**
5/15 Hz 1.5 mm
15/25 Hz 1 mm
25/55 Hz 0.25 mm (IEC68-2-6)
- Self-extinguishing capability:**
Casing and jaws: UL94 V0
- Dimensions:**
216 x 111 x 45 mm
- Mass:**
550 g
- Colours:**
Dark grey case with red jaws
- Output:**
C116: Safety sockets (4 mm)
C117: two-wire cable with reinforced insulation or double insulation, length 1.5 m, terminated by 2 insulated elbowed male banana plugs (4 mm)

Safety specifications

- Electrical safety:**
Instrument with double insulation or reinforced insulation between the primary, the secondary and the grippable part located under the guard as per IEC 1010-1 & IEC 1010-2-032
- 600 V category III, pollution degree 2
- 300 V category IV, pollution degree 2
- Electromagnetic compatibility (EMC):** :
EN 50081-1: class B
EN 50082-2:
- Electrostatic discharge: IEC 1000-4-2
- Radiated field: IEC 1000-4-3
- Fast transients: IEC 1000-4-4
- Magnetic field at 50 Hz: IEC 1000-4-8

(1) Conditions of reference: 23 °C \pm 3 °K, 20% to 75% RH, signal sinus, frequency of 48 Hz to 65 Hz, distortion factor $< 1\%$, no DC components, external magnetic field < 40 A/m, no AC magnetic field, conductor centred for measurement, load impedance $\geq 1 \text{ M}\Omega$ and $\leq 100 \text{ pF}$

(2) Out of reference domain

To order	Reference
AC current clamp model C116 with operating manual	P01120316
AC current clamp model C117 with operating manual	P01120317

CURRENT CLAMPS FOR AC CURRENT

Model C122

Current	1,000 A
Ratio	1,000/5
Output	5 mA / A

Description

An electronic voltage-limiting system protects output of clamp when operating, if the secondary circuit is opened.

Electrical specifications

- Current range:**
1 A AC .. 1,200 A AC
- Turns Ratio:**
1,000:5
- Output signal:**
5 mA AC / A AC (5 A for 1,000 A)
- Accuracy and phase shift ⁽¹⁾:**

Primary current:	1 A .. 20 A	20 A	50 A ⁽²⁾	200 A ⁽²⁾	1,000 A ⁽²⁾	1,200 A ⁽²⁾
Accuracy in %	≤ 6% + 0.5 mA	≤ 5%	≤ 3%	≤ 1.5%	≤ 1%	≤ 1%
Phase shift	not specified	≤ 3°	≤ 3°	≤ 1.5°	≤ 1°	≤ 1°

- Bandwidth:**
30 Hz .. 10 kHz
- Crest factor:**
≤ 6 for a current ≤ 3,000 A peak (500 A_{RMS})
- Maximum currents:**
1,000 A continuous for a frequency ≤ 1 kHz (limitation proportional to the inverse of frequency beyond)
1,200 A for 40 minutes max (interval between measurements > 20 minutes)
- Load impedance:**
≤ 0.6 Ω
- Impedance of connection leads:**
≤ 40 mΩ
- Max. voltage output:**
Limited to 30 V peak max.
- Operating voltage:**
600 V_{RMS}
- Common mode voltage:**
600V category III and pollution degree 2
- Influence of adjacent conductor:**
≤ 1 mA / A at 50 Hz
- Influence of conductor position in jaws:**
≤ 0.2 % of output signal for frequencies ≤ 400 Hz
- Load influence:**
From 0.2 Ω to 0.6 Ω
< 0.5 % on measurement
< 0.5 ° on phase
- Influence of frequency ⁽³⁾:**
< 1 % of output signal from 30 Hz .. 48 Hz
< 0.5 % of output signal from 65 Hz .. 1 kHz
< 1 % of output signal from 1 kHz .. 5 kHz

- Influence of crest factor:**
< 1 % of output signal for a crest factor
≤ 6 with current ≤ 3,000 A peak (500 A_{RMS})
- Influence of DC current superimposed on rated current:**
< 1 % of output signal for a current
≤ 30 A DC

Mechanical specifications

- Operating temperature:**
-10°C to +50°C
- Storage temperature:**
-40°C to +70°C
- Influence of temperature:**
≤ 0.1 % of output signal per 10 °K
- Relative humidity for operation:**
0 to 85 % RH with a linear decrease above 35 °C
- Influence of relative humidity:**
< 0.2 % of output signal from 10 % to 85 % RH
- Operating altitude:**
0 to 2,000 m
- Max. jaw opening:**
53 mm, patented progressive opening system
- Clamping capacity:**
Cable: Ø max 52 mm
Busbar: 1 busbar of 50 x 5 mm / 4 busbars of 30 x 5 mm
- Casing protection rating:**
IP40 (IEC 529)

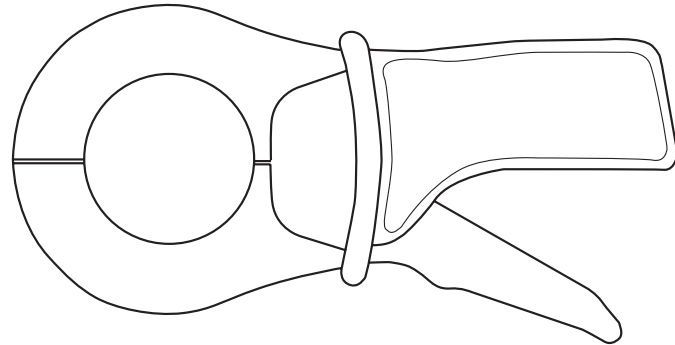

- Drop test:**
1 m (IEC 68-2-32)
- Shock resistance:**
100 g (IEC 68-2-27)
- Vibration resistance:**
5/15 Hz 1.5 mm
15/25 Hz 1 mm
25/55 Hz 0.25 mm (IEC68-2-6)
- Self-extinguishing capability:**
Casing and jaws: UL94 V0
- Dimensions:**
216 x 111 x 45 mm
- Mass:**
550 g
- Colours:**
Dark grey case with red jaws
- Output:**
Safety sockets (4mm)

Safety specifications

- Electrical safety:**
Instrument with double insulation or reinforced insulation between the primary, the secondary and the grippable part located under the guard as per IEC 1010-1 & IEC 1010-2-032
 - 600 V category III, pollution degree 2
 - 300 V category IV, pollution degree 2
- Electromagnetic compatibility (EMC) :**
EN 50081-1: class B
EN 50082-2:
 - Electrostatic discharge: IEC 1000-4-2
 - Radiated field: IEC 1000-4-3
 - Fast transients: IEC 1000-4-4
 - Magnetic field at 50 Hz: IEC 1000-4-8

(1) Conditions of reference: 23 °C ± 3 °K, 20 % to 75 % RH, signal sinus, frequency of 48 Hz to 65 Hz, distortion factor < 1 %, no DC components, external magnetic field < 40 A/m, no AC magnetic field, conductor centred for measurement, load impedance 0.2 Ω (5 VA)

(2) Accuracy class in accordance with IEC185: 5 VA - class 1 - 48 .. 65 Hz

(3) Out of reference domain

To order	Reference
AC current clamp model C122 with operating manual	P01120306

CURRENT CLAMPS FOR AC CURRENT

Model C148

Current	250 A AC	500 AAC	1,000 AAC
Ratio	250:5	500:5	1,000:5
Output	20 mA / A	10 mA / A	5 mA / A

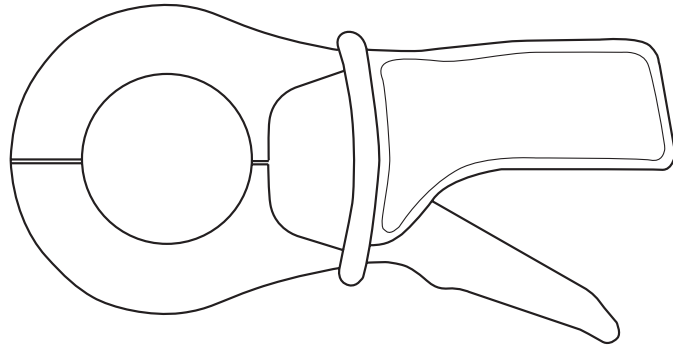

Description

An electronic voltage-limiting system protects output of clamp when operating, if the secondary circuit is opened.

Electrical specifications

- Current range:**
 - 1 A AC .. 300 A AC
 - 1 A AC .. 600 A AC
 - 1 A AC .. 1,200 A AC
- Turns ratio:**
 - 250:5
 - 500:5
 - 1,000:5
- Output signal:**
 - 20 mA AC / A AC (5 A for 250 A)
 - 10 mA AC / A AC (5 A for 500 A)
 - 5 mA AC / A AC (5 A for 1,000 A)
- Accuracy and phase shift ⁽¹⁾:**
 - 250 A calibre

Primary current:	1 A .. 5 A	5 A	12.5 A ⁽²⁾	50 A ⁽²⁾	250 A ⁽²⁾	300 A ⁽²⁾
Accuracy in %	≤ 10 % + 2 mA	≤ 10 %	≤ 5 %	≤ 2.5 %	≤ 2 %	≤ 2 %
Phase shift	not specified	not specified	≤ 10 °	≤ 10 °	≤ 10 °	≤ 10 °

- 500 A calibre

Primary current:	1 A .. 10 A	10 A	25 A ⁽³⁾	100 A ⁽³⁾	500 A ⁽³⁾	600 A ⁽³⁾
Accuracy in %	≤ 6 % + 1 mA	≤ 6 %	≤ 3 %	≤ 2 %	≤ 1 %	≤ 1 %
Phase shift	not specified	≤ 6 °	≤ 4 °	≤ 3 °	≤ 2.5 °	≤ 2.5 °

- 1,000 A calibre

Primary current:	1 A .. 20 A	20 A	50 A ⁽⁴⁾	200 A ⁽⁴⁾	1,000 A ⁽⁴⁾	1,200 A ⁽⁴⁾
Accuracy in %	≤ 6 % + 0.5 mA	≤ 5 %	≤ 3 %	≤ 1.5 %	≤ 1 %	≤ 1 %
Phase shift	not specified	≤ 5 °	≤ 3 °	≤ 1.5 °	≤ 1 °	≤ 1 °

- Bandwidth:**
 - 48 Hz .. 1 kHz
- Crest factor:**
 - 250 A calibre: ≤ 6 with current ≤ 750 A peak
 - 500 A calibre: ≤ 6 with current ≤ 1,500 A peak
 - 1,000 A calibre: ≤ 6 with current ≤ 3,000 A peak
- Maximum currents:**
 - 1,200 A for frequencies ≤ 1 kHz for 30 minutes max (interval between measurements > 15 minutes)
- Load impedance:**
 - 250 A calibre: ≤ 0.2 Ω
 - 500 A calibre: ≤ 0.4 Ω
 - 1,000 A calibre: ≤ 0.4 Ω
- Impedance of connection leads:**
 - ≤ 40 mΩ
- Maximum output voltage (secondary open):**
 - Limited to 30 V peak max.
- Operating voltage:**
 - 600 V_{RMS}
- Common mode voltage:**
 - 600V category III and pollution degree 2
- Influence of adjacent conductor:**
 - 250 A calibre: ≤ 15 mA / A at 50 Hz
 - 500 A calibre: ≤ 10 mA / A at 50 Hz
 - 1,000 A calibre: ≤ 1 mA / A at 50 Hz
- Influence of conductor position in jaws:**
 - For frequencies ≤ 400 Hz
 - 250 A calibre: ≤ 0.6 % of output signal
 - 500 A calibre: ≤ 0.4 % of output signal
 - 1,000 A calibre: ≤ 0.2 % of output signal
- Load influence:**
 - 250 A calibre:
 - from 25 mΩ to 0.2 Ω
 - < 2 % on measurement
 - < 4° on phase
 - 500 A calibre:
 - from 50 mΩ to 0.4 Ω
 - < 1 % on measurement
 - < 2° on phase
 - 1,000 A calibre:
 - from 50 mΩ to 0.4 Ω
 - < 0.5 % on measurement
 - < 0.5° on phase
- Influence of frequency ⁽⁵⁾:**
 - 250 A calibre:
 - < 1 % of output signal from 65 Hz .. 100Hz
 - < 5 % of output signal from 100 Hz .. 1 kHz
 - 500 A calibre:
 - < 1 % of output signal from 65 Hz .. 1 kHz
 - 1,000 A calibre:
 - < 0.5 % of output signal from 65 Hz .. 100Hz
 - < 1 % of output signal from 100 Hz .. 1 kHz
- Influence of crest factor:**
 - < 1 % of output signal for crest factor ≤ 6 with current:
 - ≤ 750 A peak (calibre 250 A)
 - ≤ 1,500 A peak (calibre 500 A)
 - ≤ 3,000 A peak (1,000 A calibre)
- Influence of DC current superimposed on rated current:**
 - < 1 % of output signal for a current ≤ 30 A DC

CURRENT CLAMPS FOR AC CURRENT

Model C148

Mechanical specifications

- **Operating temperature:**
-10°C to +50°C
- **Storage temperature:**
-40°C to +70°C
- **Influence of temperature:**
≤ 0.15 % of output signal per 10 °K
- **Relative humidity for operation:**
0 to 85 % RH with a linear decrease above 35 °C
- **Influence of relative humidity:**
From 10 % to 85 % RH
- **250 A calibre:**
< 0.6 % of output signal and < 2° on phase
- **500 A calibre:**
< 0.4 % of output signal and < 0.6° on phase
- **1,000 A calibre:**
< 0.2 % of output signal and < 0.2° on phase
- **Operating altitude:**
0 to 2,000 m
- **Max. jaw opening:**
53 mm, patented progressive opening system

- **Clamping capacity:**
Cable: Ø max 52 mm
Busbar: 1 busbar of 50 x 5 mm / 4 busbars of 30 x 5 mm
- **Casing protection rating:**
IP40 (IEC 529)
- **Drop test:**
1 m (IEC 68-2-32)
- **Shock resistance:**
100 g (IEC 68-2-27)
- **Vibration resistance:**
5/15 Hz 1.5 mm
15/25 Hz 1 mm
25/55 Hz 0.25 mm (IEC68-2-6)
- **Self-extinguishing capability:**
UL94 V0
- **Dimensions:**
216 x 111 x 45 mm
- **Mass:**
550 g
- **Colours:**
Dark grey case with red jaws
- **Output:**
Safety sockets (4mm)

Safety specifications

- **Electrical safety:**
Instrument with double insulation or reinforced insulation between the primary, the secondary and the grippable part located under the guard as per IEC 1010-1 & IEC 1010-2-032
 - 600 V category III, pollution degree 2
 - 300 V category IV, pollution degree 2
- **Electromagnetic compatibility (EMC) :**
EN 50081-1: class B
EN 50082-2:
 - Electrostatic discharge: IEC 1000-4-2
 - Radiated field: IEC 1000-4-3
 - Fast transients: IEC 1000-4-4
 - Magnetic field at 50 Hz: IEC 1000-4-8

(1) Conditions of reference: 23 °C ± 3 °K, 20 % to 75 % RH, signal sinus, frequency of 48 Hz to 65 Hz, distortion factor < 1 %, external magnetic field < 40 A/m, no AC magnetic field, conductor centred for measurement, load impedance:

- 250 A calibre: 0.1 Ω (2.5 VA)

- 500 A calibre: 0.2 Ω (5 VA)

- 1,000 A calibre: 0.2 Ω (5 VA)

(2) Accuracy class in accordance with IEC185: 2.5 VA - class 3 - 48-65 Hz

(3) Accuracy class in accordance with IEC185: 5 VA - class 3 - 48-65 Hz

(4) Accuracy class in accordance with IEC185: 5 VA - class 1 - 48-65 Hz

(5) Out of reference domain

To order	Reference
AC current clamp model C148 with operating manual	P01120307

CURRENT CLAMPS FOR AC CURRENT

Model C160 (insulated AC current probe)

Current	30 A peak	300 A peak	2,000 A peak
Output	100 mV / A	10 mV / A	1 mV / A

Description

This 1,000 A AC clamp enables easy display and measurement of "current" curves. It fits any oscilloscope since it has a coaxial lead with BNC plug.

It produces a mV signal directly proportional to current. It offers 3 different sensitivities.

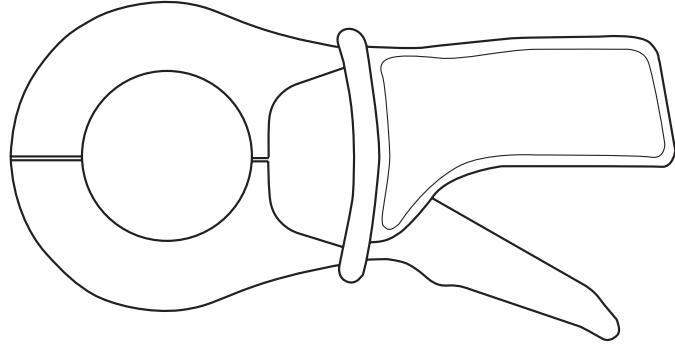

Electrical specifications

- Current range:**
 - 0.1 A AC .. 10 A AC (30 A peak)
 - 1 A AC .. 100 A AC (300 A peak)
 - 1 A AC .. 1,000 A AC (2,000 A peak)

- Output signal:**
 - 100 mV AC / A AC (1 V for 10 A)
 - 10 mV AC / A AC (1 V for 100 A)
 - 1 mA AC / A AC (1 V for 1,000 A)

- Accuracy and phase shift ⁽¹⁾:**
- 10 A calibre

Primary current:	0.1 A .. 0.5 A	0.5 A .. 2 A	2 A .. 10 A	10 A .. 12 A
Accuracy in % of output signal	≤ 3% + 10 mV	≤ 3% + 10 mV	≤ 3% + 10 mV	≤ 3% + 10 mV
Phase shift	not specified	not specified	≤ 15°	≤ 15°

- 100 A calibre

Primary current:	0.1 A .. 5 A	5 A .. 20 A	20 A .. 100 A	100 A .. 120 A
Accuracy in % of output signal	≤ 2% + 5 mV	≤ 2% + 5 mV	≤ 2% + 5 mV	≤ 2% + 5 mV
Phase shift	not specified	≤ 15°	≤ 10°	≤ 5°

- 1,000 A calibre

Primary current:	1 A .. 50 A	50 A .. 200 A	200 A .. 1,000 A	1,000 A .. 1,200 A
Accuracy in % of output signal	≤ 1% + 1 mV	≤ 1% + 1 mV	≤ 1% + 1 mV	≤ 1% + 1 mV
Phase shift	not specified	≤ 3°	≤ 2°	≤ 1°

- Bandwidth:**
 - 10 Hz .. 100 kHz (-3 dB) (depending on current value)
- Rise/fall time from 10 % to 90 %:**
 - 3.5 μs
- 10 % delay time:**
 - 0.5 μs
- Ampere second product:**
 - 10 A calibre: 3.2 A.s
 - 100 A calibre: 26 A.s
 - 1,000 A calibre: 64 A.s
- Maximum currents:**
 - 1,000 A permanent
 - 1,200 A for 40 minutes / 20 minutes shutdown for a frequency ≤ 1 kHz (limitation proportional to the inverse of one third of the frequency beyond that)
- Insertion impedance (at 400 Hz / 10 kHz)**
 - 10 A calibre: < 0.3 mΩ / < 6.6 mΩ
 - 100 A calibre: < 0.3 mΩ / < 2 mΩ
 - 1,000 A calibre: < 0.3 mΩ / < 1.6 mΩ

- Output impedance at 1 kHz:**
 - 10 A calibre: ≤ 515 Ω ± 10 %
 - 100 A calibre: ≤ 515 Ω ± 10 %
 - 1,000 A calibre: ≤ 515 Ω ± 10 %
- Influence of temperature:**
 - ≤ 150 ppm / k or 0.15 % of output signal per 10 °K
- Influence of relative humidity:**
 - < 0.1 % of output signal
- Influence of adjacent conductor:**
 - ≤ 1 mA / A at 50 Hz
- Influence of DC current ≤ 30 A superimposed on rated current:**
 - < 1%
- Influence of conductor position in jaws:**
 - ≤ 0.1 % of output signal for frequencies ≤ 400 Hz

- Influence of frequency ⁽²⁾:**
- 10 A calibre:
 - < 10 % of output signal from 10 Hz .. 1kHz
 - < 5 % of output signal from 1 kHz .. 10kHz
 - < 20 % of output signal from 10 kHz .. 50 kHz
 - 3 dB of output signal from 50 kHz .. 100 kHz
- 100 A calibre:
 - < 5 % of output signal from 10 Hz .. 1kHz
 - < 3 % of output signal from 1 kHz .. 10kHz
 - < 20 % of output signal from 10 kHz .. 50 kHz
 - 3 dB of output signal from 50 kHz .. 100 kHz
- 1,000 A calibre:
 - < 1 % of output signal from 10 Hz .. 1kHz
 - < 2 % of output signal from 1 kHz .. 10kHz
 - < 10 % of output signal from 10 kHz .. 50 kHz
 - 3 dB of output signal from 50 kHz .. 100 kHz
- Influence of crest factor:**
 - < 1 % of output signal for crest factor ≤ 6 with current
- 10 A calibre: ≤ 30 A peak
- 100 A calibre: ≤ 300 A peak
- 1,000 A calibre: ≤ 3,000 A peak

CURRENT CLAMPS FOR AC CURRENT

Model C160 (insulated AC current probe)

Mechanical specifications

- **Max. jaw opening:**
53 mm
- **Clamping capacity:**
Cable: \emptyset max 52 mm
Busbar: 1 busbar of 50 x 5 mm / 4 busbars of 30 x 5 mm
- **Operating temperature:**
-10°C to +55°C
- **Storage temperature:**
-40°C to +70°C
- **Relative humidity for operation:**
0 to 85 % RH with a linear decrease above 35 °C
- **Operating altitude:**
0 to 2,000 m
- **Casing protection rating:**
IP30 with clamp open (IEC 529)
IP40 with clamp closed (IEC 529)
- **Drop test:**
1 m (IEC 68-2-32)
- **Shock resistance:**
100 g / 6 ms / half-period (IEC 68-2-27)

- **Protection against impacts:**
IK04 0.5 J (EN 50102)
- **Vibration resistance:**
5/15 Hz 1.5 mm peak
15/25 Hz 1 mm peak
25/55 Hz 0.25 mm peak (IEC68-2-6)
- **Self-extinguishing capability:**
Casing and jaws: UL94 V0
- **Dimensions:**
216 x 111 x 45 mm
- **Mass:**
550 g
- **Colours:**
Dark grey case with red jaws
- **Output:**
Coaxial cable 2 m long, terminated by an insulated BNC connector

Safety specifications

- **Electrical safety:**
Instrument with double insulation or reinforced insulation between the primary, the secondary and the grippable part located under the guard as per IEC 1010-1 & IEC 1010-2-032
 - 600 V category III, pollution degree 2
 - 300 V category IV, pollution degree 2
- **Electromagnetic compatibility (EMC):** :
EN 50081-1: class B
EN 50082-2:
 - Electrostatic discharge: IEC 1000-4-2
without disturbance: 4 kV class 2 non-destructive: 15 kV class 4
 - Radiated field: IEC 1000-4-3
without disturbance: 10 V/m performance criterion A
 - Fast transients: IEC 1000-4-4
without disturbance: 1 kV class 2
non-destructive: 2 kV class 3
 - Magnetic field at 50/60Hz: IEC 1000-4-8
field of 400 A/m at 50 Hz: < 1 A

(1) Conditions of reference: 23 °C \pm 3 °K, 20 % to 75 % RH, signal sinus, frequency of 48 Hz à 1,000 Hz, distortion factor < 1 % with no DC component, external magnetic field < 40 A/m, no DC components, no external conductor with circulating current, conductor centred for measurement, load impedance: \geq 1 M Ω and < 100 pF

(2) Out of reference domain

To order	Reference
AC current clamp model C160 with operating manual	P01120308

CURRENT CLAMPS FOR AC CURRENT

Model C160 (insulated AC current probe)

Curves at 50 Hz

1,000 A calibre

Error on measurement

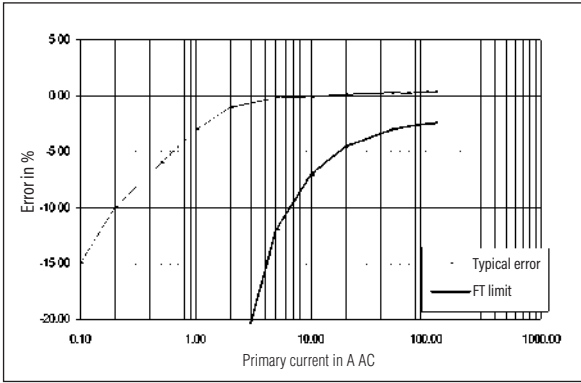

Phase shift

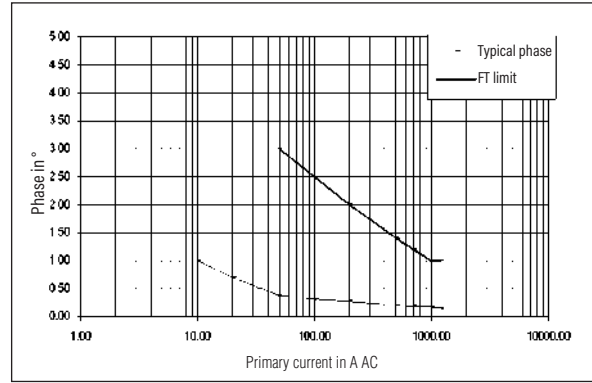

100 A calibre

Error on measurement

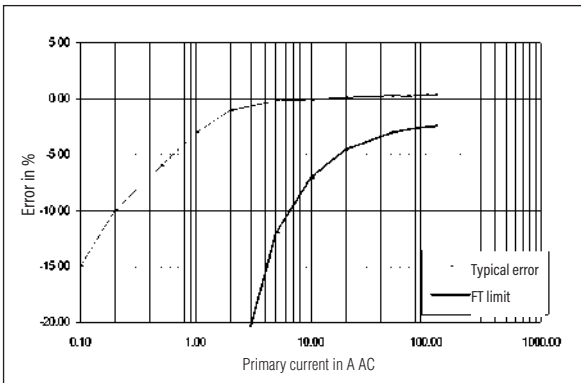

Phase shift

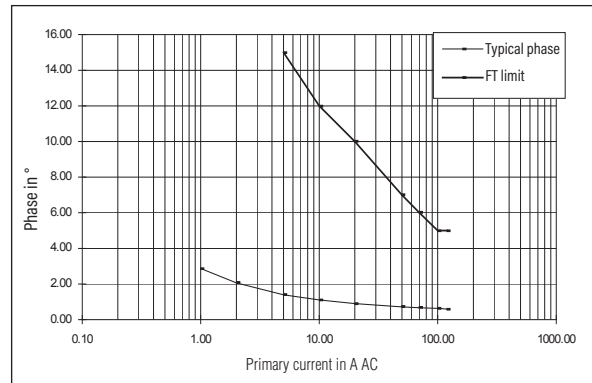

10 A calibre

Error on measurement

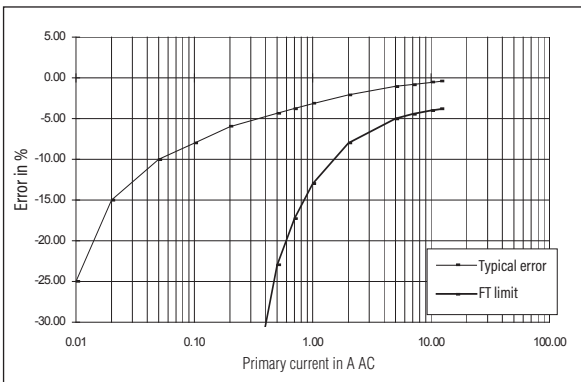

Phase shift

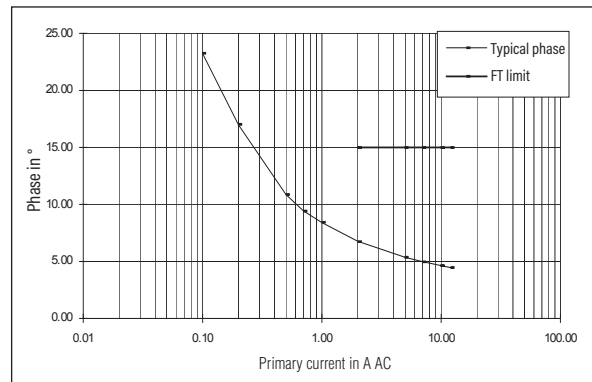

CURRENT CLAMPS FOR AC CURRENT

Model C160 (insulated AC current probe)

Frequency response (cont.)

1,000 A calibre

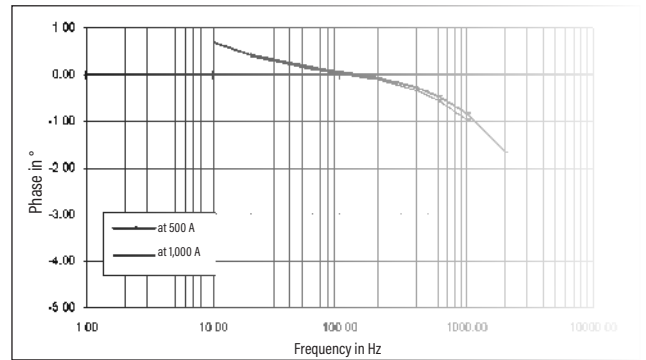
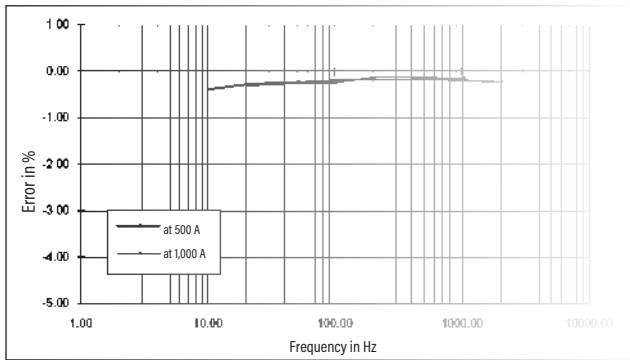
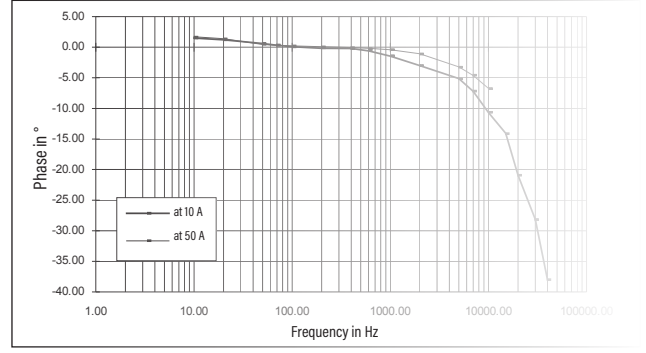
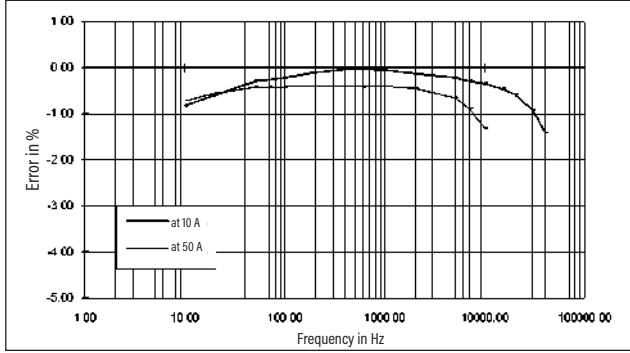

100 A calibre

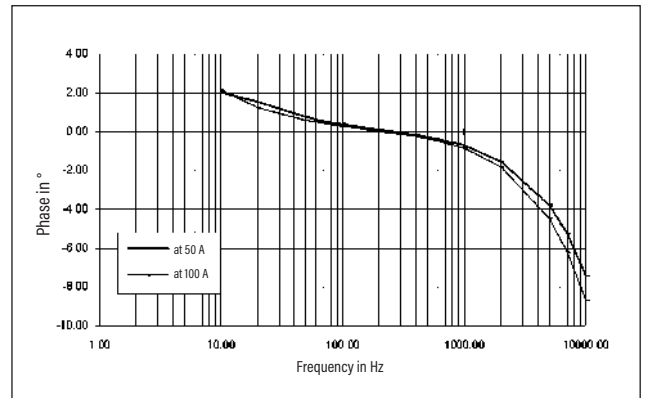
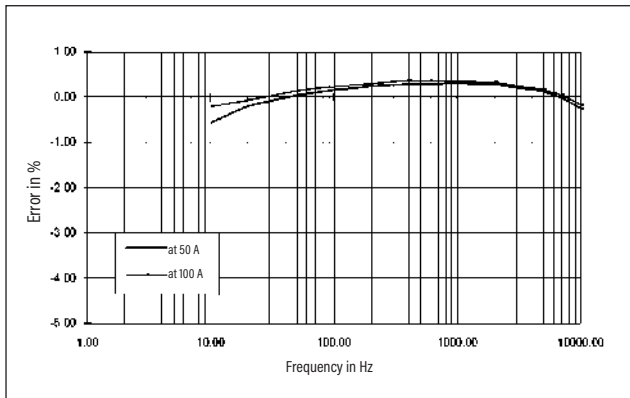
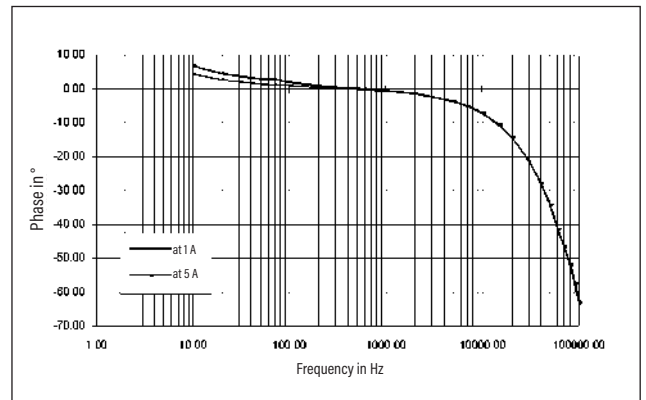
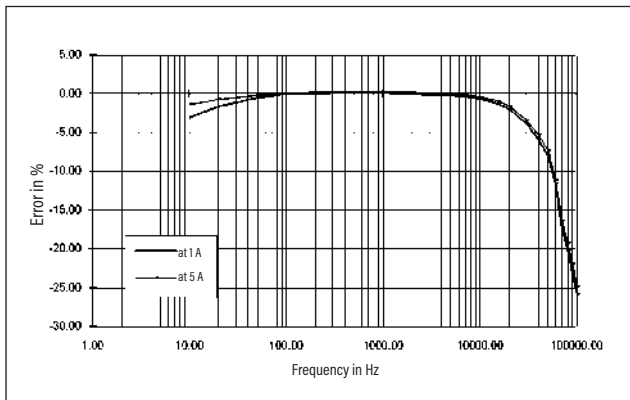

CURRENT CLAMPS FOR AC CURRENT

Model C160 (insulated AC current probe)

Frequency response (cont.)

10 A calibre

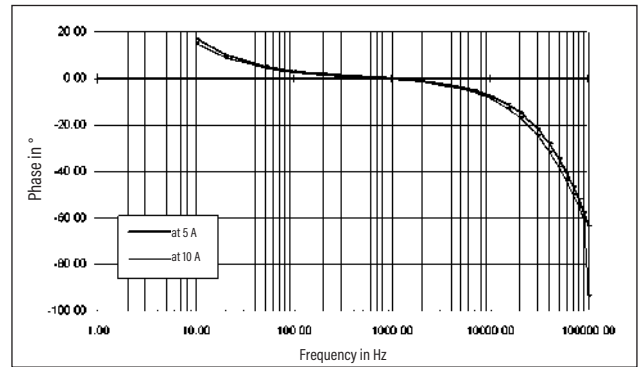
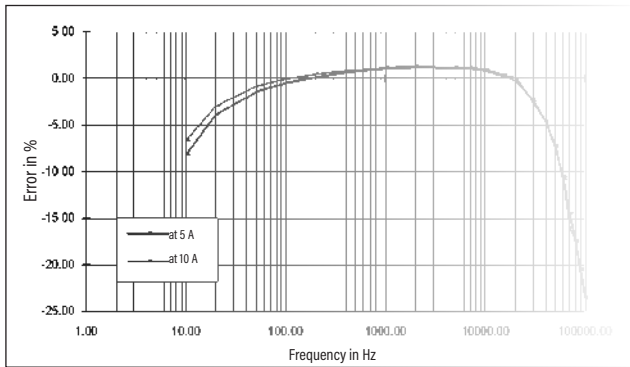
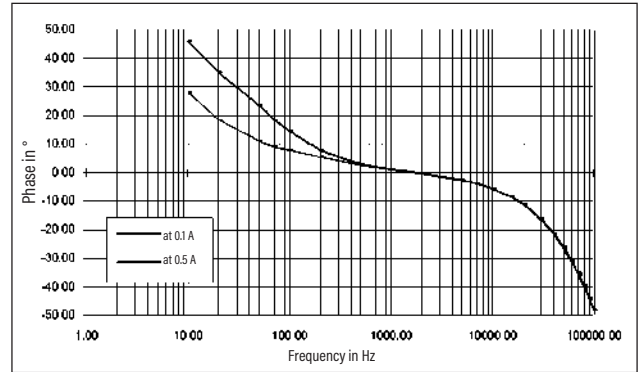
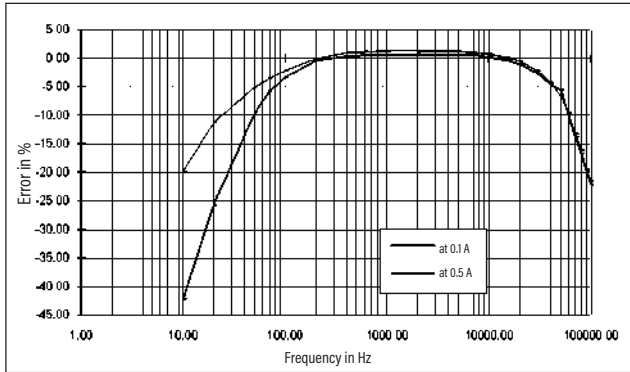

Response to a square signal

1,000 A calibre

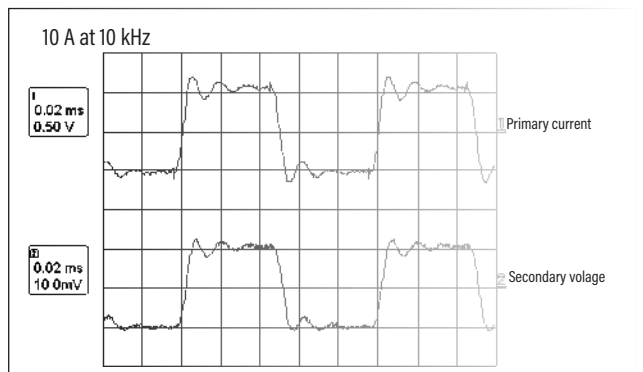
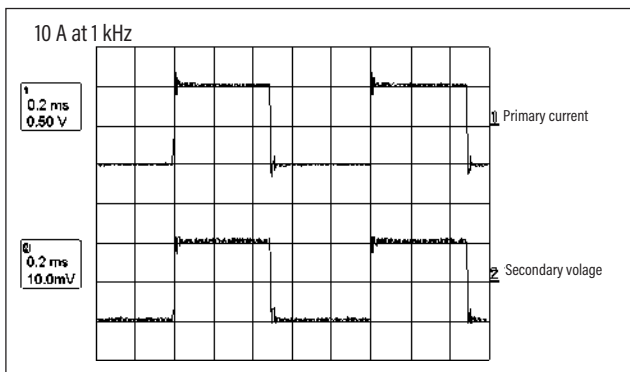
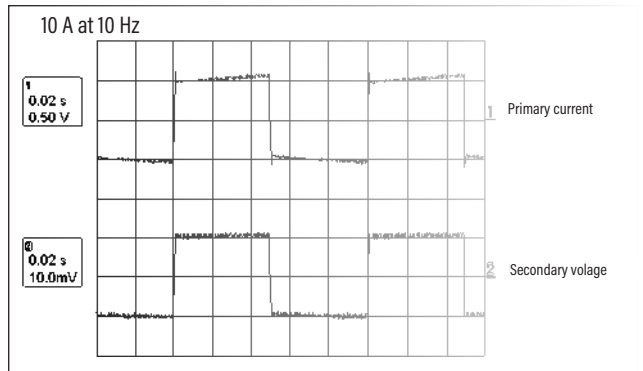
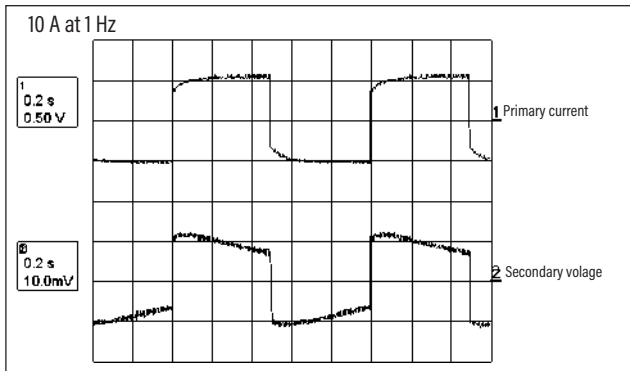

CURRENT CLAMPS FOR AC CURRENT

Model C160 (insulated AC current probe)

Response to a square signal (cont.)

100 A calibre

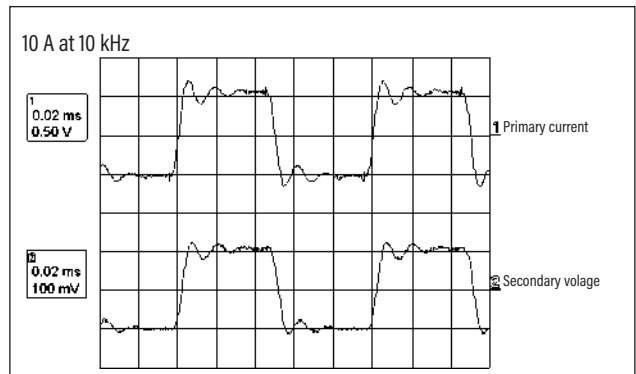
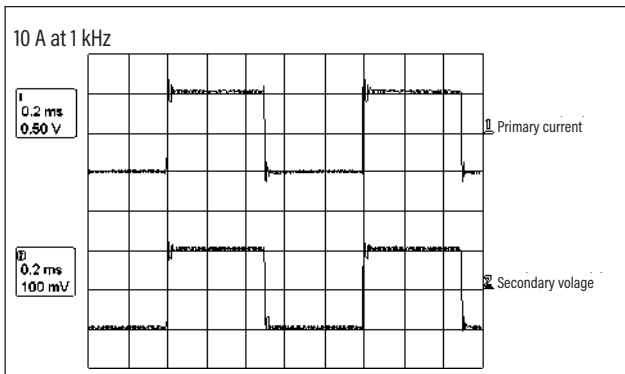
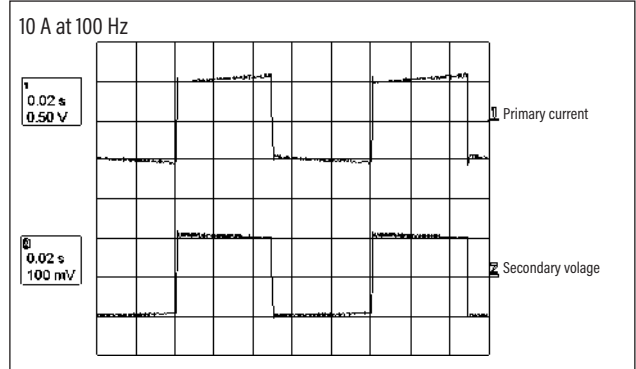
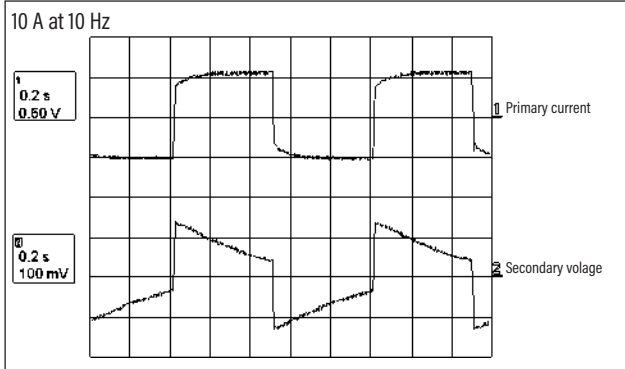

10 A calibre

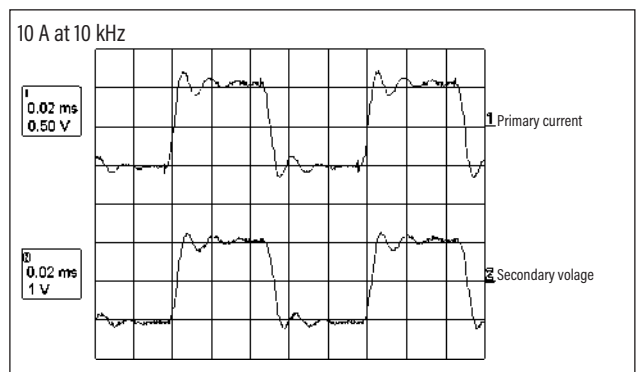
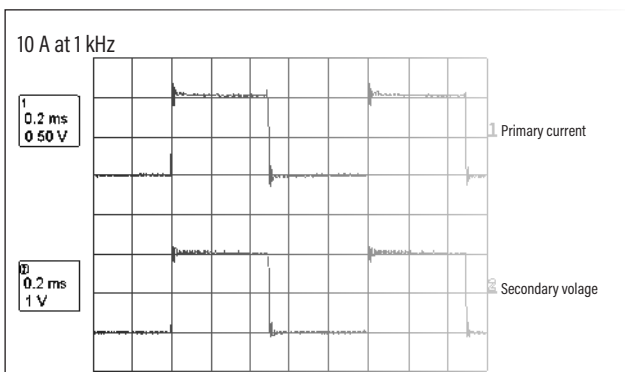
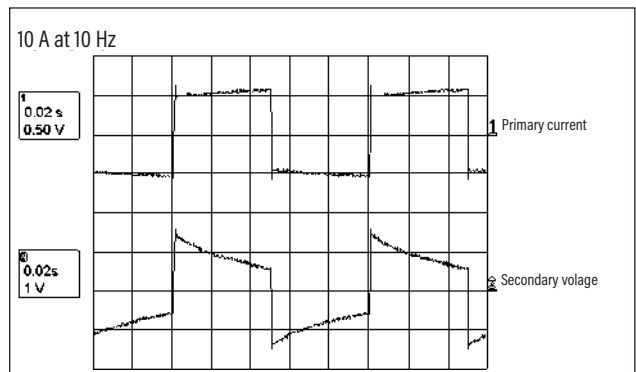
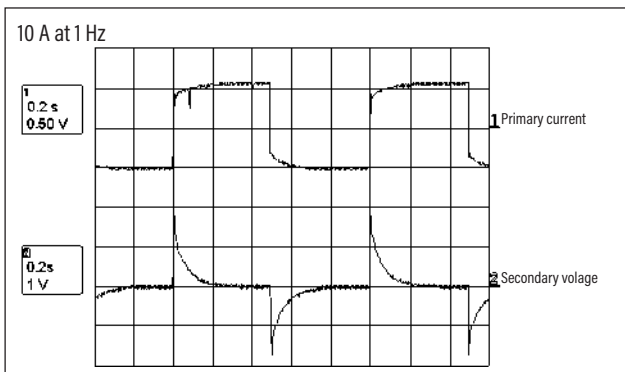

CURRENT CLAMPS FOR AC CURRENT

Model C173 (probe for leakage currents)

Current	1 A	10 A	100 A	1,000 A
Output	1 V / A	100 mV / A	10 mV / A	1 mV / A

Description

The C173 clamp measures leakage or differential currents from 1 mA upwards and can also be used with multimeters equipped with a range in mV AC.

The C173 clamp measures earth-loop currents and leakage currents. It also locates faults in circuits of single and three-phase networks.

For unearthed three-phase systems, use the optional Artificial Neutral.

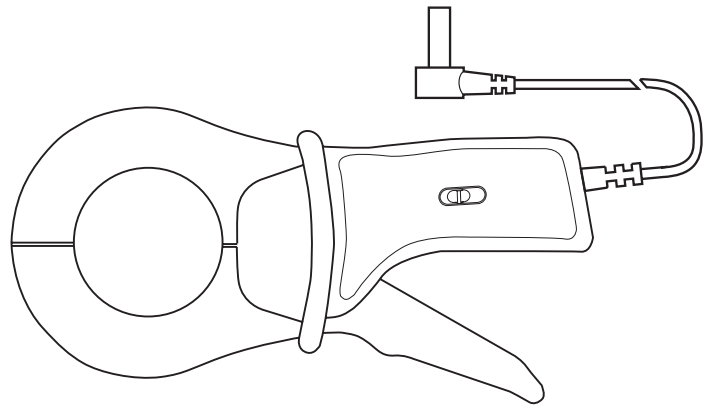

Electrical specifications

- **Current range:**
0.001 A AC.. 1.2 A AC
0.01 A AC .. 12 A AC
0.1 A AC .. 120 A AC
1 A AC .. 1,200 A AC
- **Output signal:**
1 V AC / A AC (1 V for 1 A)
100 mV AC / A AC (1 V for 10 A)
10 mV AC / A AC (1 V for 100 A)
1 mV AC / A AC (1 V for 1,000 A)
- **Accuracy and phase shift ⁽¹⁾:**

- 1 A calibre

Primary current:	0.001 A .. 0.01 A	0.01 A .. 0.1 A	0.1 A .. 1 A	1 A .. 1.2 A
Accuracy in % of output signal	≤ 3% + 1 mV	≤ 3% + 1 mV	≤ 0.7% + 1 mV	≤ 0.7% + 1 mV
Phase shift	not specified	not specified	≤ 10°	≤ 10°

- 10 A calibre

Primary current:	0.01 A .. 0.1 A	0.1 A .. 1 A	1 A .. 10 A	10 A .. 12 A
Accuracy in % of output signal	≤ 1% + 0.2 mV	≤ 0.5% + 0.2 mV	≤ 0.5%	≤ 0.5%
Phase shift	not specified	≤ 5°	≤ 2°	≤ 2°

- 100 A calibre

Primary current:	0.1 A .. 1 A	1 A .. 10 A	10 A .. 100 A	100 A .. 120 A
Accuracy in % of output signal	≤ 1% + 0.2 mV	≤ 0.5% + 0.2 mV	≤ 0.3%	≤ 0.2%
Phase shift	not specified	≤ 2°	≤ 1°	≤ 1°

- 1,000 A calibre

Primary current:	1 A .. 10 A	10 A .. 100 A	100 A .. 1,000 A	1,000 A .. 1,200 A
Accuracy in % of output signal	≤ 1% + 0.2 mV	≤ 0.5% + 0.2 mV	≤ 0.2%	≤ 0.2%
Phase shift	not specified	≤ 2°	≤ 1°	≤ 1°

- **Bandwidth:**

10 Hz .. 3 kHz

- **Crest factor:**

- 1 A calibre: ≤ 3 for I ≤ 3 A peak (1 A_{RMS})
- 10 A calibre: ≤ 3 for I ≤ 30 A peak (10 A_{RMS})
- 100 A calibre: ≤ 3 for I ≤ 300 A peak (100 A_{RMS})
- 1,000 A calibre: ≤ 3 for I ≤ 1700 A peak (500 A_{RMS})

- **Maximum currents:**

1,000 A continuous for a frequency ≤ 500 Hz (limitation proportional to the inverse of 1/2 of frequency beyond)

- **Load impedance:**

≥ 10 MΩ and ≤ 47 pF

- **Output impedance:**

- 1 A calibre: 10 kΩ ± 10%
- 10 A calibre: 1 kΩ ± 10%
- 100 A calibre: 100 Ω ± 10%
- 1,000 A calibre: 100 Ω ± 10%

- **Operating voltage:**

600 V_{RMS}

- **Common mode voltage:**

600V category III and pollution degree 2

- **Influence of adjacent conductor:**

≤ 1 mA / A at 50 Hz

- **Influence of conductor position in jaws:**

≤ 0.3 % of output signal for frequencies ≤ 400 Hz

- **Influence of frequency ⁽²⁾:**

- 1 A calibre:
< 2 % of output signal 30 Hz .. 48 Hz and 65 Hz .. 1 kHz < 10 % of output signal 1 kHz .. 3 kHz
- 10 A calibre:
< 2 % of output signal 10 Hz .. 48 Hz and 65 Hz .. 3 kHz
- 100 A calibre:
< 1.5 % of output signal 10 Hz .. 48 Hz and 65 Hz .. 3 kHz
- 1,000 A calibre:
< 1 % of output signal 10 Hz .. 48 Hz and 65 Hz .. 1 kHz
- **Influence of crest factor:**
≤ 0.5 % for crest factor limited to 3
- **Influence of DC current superimposed on rated current:**
≤ 10 % at 1,000 A for a current DC from 10 A

CURRENT CLAMPS FOR AC CURRENT

Model C173 (probe for leakage currents)

Mechanical specifications

- **Operating temperature:**
-10 °C .. +50 °C
- **Storage temperature:**
-40 °C .. +70 °C
- **Influence of temperature:**
≤ 0.15 % of output signal per 10 °K from -10 °C .. +40 °C
≤ 0.2 % of output signal per 10 °K from +40 °C .. +50 °C
- **Relative humidity for operation:**
From 0 .. 85 % from RH decreasing linearly above 35 °C
- **Influence of relative humidity:**
< 0.1 % of output signal from 10 .. 85 % from RH
- **Operating altitude:**
0 to 2,000 m
- **Max. jaw opening:**
53mm
patented progressive opening system
- **Clamping capacity:**
Cable: Ø max 52 mm

- **Busbar:** 1 busbar of 50 x 5 mm or 4 busbars of 30 x 5 mm
- **Casing protection rating:**
IP40 (IEC 529)
- **Drop test:**
1 m (IEC 68-2-32)
- **Shock resistance:**
100 g (IEC 68-2-27)
- **Vibration resistance:**
5/15 Hz 1.5 mm
15/25 Hz 1 mm
25/55 Hz 0.25 mm (IEC68-2-6)
- **Self-extinguishing capability:**
UL94 V0
- **Dimensions:**
216 x 111 x 45 mm
- **Mass:**
550 g
- **Colours:**
Dark grey case with red jaws
- **Output:**

1.5 m two-wire lead with double or reinforced insulation terminated by 2 elbowed male safety plugs (4 mm)

Safety specifications

- **Electrical safety:**
Instrument with double insulation or reinforced insulation between the primary, the secondary and the grippable part located under the guard as per IEC 1010-1 & IEC 1010-2-032
- 600 V category III, pollution degree 2
- 300 V category IV, pollution degree 2
- **Electromagnetic compatibility (EMC):** :
EN 50081-1: class B
EN 50082-2:
- Electrostatic discharge: IEC 1000-4-2
- Radiated field: IEC 1000-4-3
- Fast transients: IEC 1000-4-4
- Magnetic field at 50/60Hz: IEC 1000-4-8

(1) Conditions of reference: 23 °C ± 3 °K, 20 % to 75 % RH, signal sinus, frequency of 48 Hz to 65 Hz, distortion factor < 1 %, no DC components, external magnetic field < 40 A/m, no AC magnetic field, conductor centred for measurement, load impedance: ≥ 10 MΩ and ≤ 47 pF

(2) Out of reference domain

To order	Reference
AC current clamp model C173 with operating manual	P01120309

CURRENT CLAMPS FOR AC CURRENT



D_N SERIES

The D_N series comprises a range of high-performance clamp-on AC current probes designed for high current measurements. Their excellent current transformation ratios and low phase shift, combined with a broad frequency response, allows highly accurate current and power measurements. High-quality magnetic cores and windings mean high precision current measurement up to 3,000 AAC. The rectangular jaws can be used to clamp large-diameter cables or busbars.

The D_N series clamps provide true RMS measurement values and faithful signal reproduction.

Two types are available. The first acts as a traditional current transformer with a current output (mA) and a wide range of turns ratios.

These clamps may also be used with multimeters, harmonic and power measurement equipment, logging apparatus or other instruments allowing AC current input.

The second type of model gives a voltage output with precise proportion to the measured current (1 mV/A, 10 mV/A or 100 mV/A). This voltage output enables instruments that do not have a current channel to measure, display or store values via their voltage channel.

Model D38N has been specifically designed for use with oscilloscopes, or other instruments with a BNC input.

CURRENT CLAMPS FOR AC CURRENT

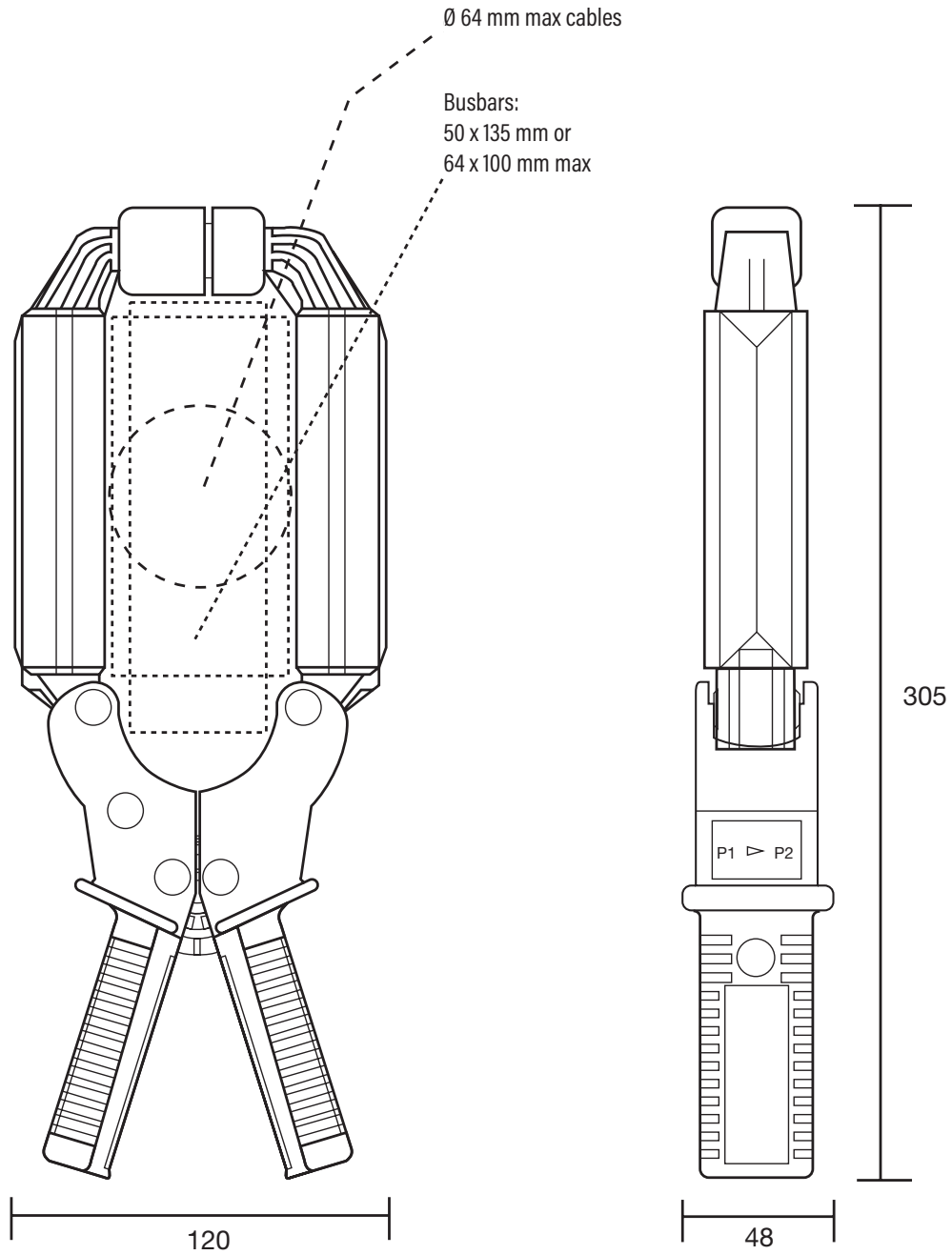

CURRENT CLAMPS FOR AC CURRENT

Models D30N and D30CN

Current	2,400 A AC
Ratio	3,000:1
Output	0.333 mA / A

Electrical specifications

- Current range:**
1 A AC .. 2,400 A AC
(3,000 A for temperature < 35 °C)
- Turns Ratio:**
3,000:1
- Output signal:**
0.333 mA / A AC (1 A to 3,000 A)
- Accuracy and phase shift ⁽¹⁾:**

Primary current:	150 A	600 A	3,000 A
Accuracy in % of output signal	1.5 %	0.75 %	0.5 %
Phase shift	1.5°	0.75°	0.5°

- Overload:**
3600 A for 5 minutes
- Maximum output voltage (secondary open):**
Electronic protection circuit limiting voltage to 42 V peak max.
- Accuracy:**
In accordance with IEC185-26-27, 5 VA, class 0.5 from 48 Hz to 1,000 Hz
- Bandwidth:**
30 Hz to 5 kHz (in continuous use above 1 kHz, the max. measurement current is limited)
- Ampere second product:**
90 A.s
- Load impedance:**
< 5 Ω
- Operating voltage:**
600 V AC
- Common mode voltage:**
600 V AC
- Influence of adjacent conductor:**
0.005 A / A AC
- Influence of conductor position in jaws:**
1 % ± 0.1 A

Mechanical specifications

- Operating temperature:**
-10°C to +50°C
- Storage temperature:**
-25°C to +80°C
- Influence of temperature:**
< 0.1 % per 10 °K
- Max. jaw opening:**
90 mm
- Clamping capacity:**
Cable: Cable: 64mm
Group of wires: 50 x 135 mm - 64 x 100 mm
- Casing protection rating:**
IP20 in accordance with IEC 529
- Drop test:**
500 mm (IEC 68-2-32)
- Shock resistance:**
100 g, in accordance with IEC68-2-27
- Vibration resistance:**
10 / 55/10 Hz, 0.15 mm test in accordance with IEC68-2-6
- Self-extinguishing capability:**
Casing: UL94 V0
Jaws: UL94 V2
- Dimensions:**
120 x 315 x 48 mm
- Weight:**
1,200 g
- Colour:**
Dark grey case with red jaws
- Output:**
D30N: two safety sockets (4 mm)
D30CN: Two-wire cable with reinforced insulation or double insulation, 1.5 m in length, terminated with 2 elbowed male safety plug connectors (4 mm)

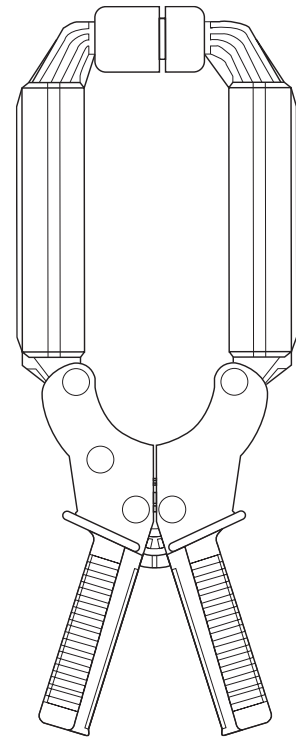

Safety specifications

- Electrical safety:**
Double or reinforced insulation between the primary and secondary circuits and the outer casing in accordance with IEC 1010-2-032
 - 600 V category III, pollution degree 2
 - 300 V category IV, pollution degree 2
- Electromagnetic compatibility (EMC):**
EN 50081-1: class B
EN 50082-2:
 - Electrostatic discharge: IEC 1000-4-2
 - Radiated field: IEC 1000-4-3
 - Fast transients: IEC 1000-4-4
 - Magnetic field at 50/60Hz: IEC 1000-4-8

(1) Conditions of reference: 23 °C ± 5 °K, 20 % to 75 % RH, 48 Hz to 65 Hz, external magnetic field < 40 A/m, no DC component, no current-carrying conductor nearby, centred test sample, load impedance 5 Ω.

To order	Reference
AC current clamp model D30N with operating manual	P01120049A
AC current clamp model D30CN with operating manual	P01120064

CURRENT CLAMPS FOR AC CURRENT

Model D31N

Current	500 A AC	1,000 A AC	1,500 A AC
Ratio	500:1	1,000:1	1,500:1
Output	2 mA / A	1 mA / A	0.66 mA / A

Electrical specifications

- Current range:**
1 A AC .. 500 A AC
1 A AC .. 1,000 A AC
1 A AC .. 1,500 A AC
- Turns Ratio:**
500:1, 1,000:1, 1,500:1
- Output signal:**
2 mA / A AC (1 A for 500 A)
1 mA / A AC (1 A for 1,000 A)
0.66 mA / A AC (1 A for 1,500 A)
- Accuracy and phase shift ⁽¹⁾:**

500 A calibre:

Primary current:	25 A	100 A	500 A
Accuracy in % of output signal	4 %	3 %	3 %
Phase shift	4°	3.5°	2°

Load impedance: 5 Ω

Overload: 700 A for 10 minutes

Ampere second product: 6 A.s

Accuracy: in accordance with IEC185-26-27, 5 VA, Class 3 from 48 Hz to 1,000Hz

- 1,000 A calibre:

Primary current:	50 A	200 A	1,000 A
Accuracy in % of output signal	3 %	1.5 %	1 %
Phase shift	3°	1.5°	1°

Load impedance: 5 Ω

Overload: 1,400 A for 10 minutes

Ampere second product: 30 A.s

Accuracy: in accordance with IEC185-26-27, 5 VA, Class 1 from 48 Hz to 1,000Hz

- 1,500 A calibre:

Primary current:	75 A	300 A	1,500 A
Accuracy in % of output signal	1.5 %	0.75 %	0.5 %
Phase shift	1.5°	0.75°	0.5°

Load impedance: 5 Ω

Overload: 1,800 A for 10 minutes

Ampere second product: 65 A.s

Accuracy: in accordance with IEC185-26-27, 5 VA, Class 0.5 from 48 Hz to 1,000 Hz

- Bandwidth:**
30 Hz to 1,500 Hz (in continuous use above 1 kHz the max. measurement current is limited)
- Load impedance:**
< 5 Ω
- Operating voltage:**
600 V AC
- Common mode voltage:**
600 V AC
- Maximum output voltage (secondary open):**
Limited to 42 V peak max.
- Influence of adjacent conductor:**
0.005 A / A AC
- Influence of conductor position in jaws:**
1.5 % ± 0.2 A on the 500:1 ratio
1 % ± 0.2 A on the 1,000:1 ratio
1 % ± 0.2 A on the 1,500:1 ratio

Mechanical specifications

- Operating temperature:**
-10°C to +50°C
- Storage temperature:**
-25°C to +80°C
- Influence of temperature:**
< 0.1 % per 10 °K
- Max. jaw opening:**
90 mm
- Clamping capacity:**
Cable: Cable: 64mm
Group of wires: 50 x 135 mm - 64 x 100 mm
- Casing protection rating:**
IP20 in accordance with IEC 529
- Drop test:**
500 mm (IEC 68-2-32)
- Shock resistance:**
100 g, in accordance with IEC68-2-27
- Vibration resistance:**
10 / 55/10 Hz, 0.15 mm test in accordance with IEC68-2-6
- Self-extinguishing capability:**
Casing: UL94 V0
Jaws: UL94 V2
- Dimensions:**
120 x 315 x 48 mm
- Weight:**
1,200 g

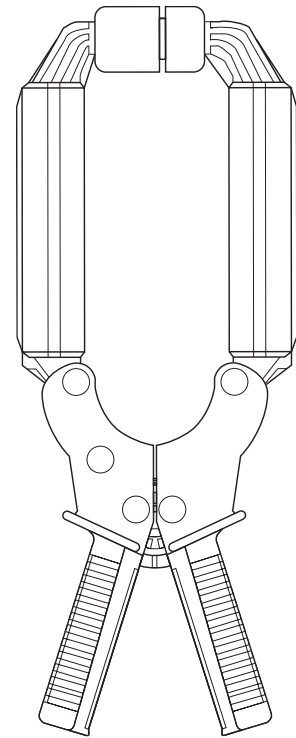

- Colour:**
Dark grey case with red jaws
- Output:**
2 safety sockets (4 mm)

Safety specifications

- Electrical safety:**
Double or reinforced insulation between the primary and secondary circuits and the outer casing in accordance with IEC 1010-2-032
- 600 V category III, pollution degree 2
- 300 V category IV, pollution degree 2
- Electromagnetic compatibility (EMC):**
EN 50081-1: class B
EN 50082-2:
- Electrostatic discharge: IEC 1000-4-2
- Radiated field: IEC 1000-4-3
- Fast transients: IEC 1000-4-4
- Magnetic field at 50/60Hz: IEC 1000-4-8

(1) Conditions of reference: 23 °C ± 5 °K, 20 % to 75 % RH, 48 Hz to 65 Hz, external magnetic field < 40 A/m, no DC component, no current-carrying conductor nearby, centred test sample.

To order	Reference
AC current clamp model D31N with operating manual	P01120050A

CURRENT CLAMPS FOR AC CURRENT

Model D32N

Current	1,000 A AC	2,000 A AC	2,400 A AC
Ratio	1,000:1	2,000:1	3,000:1
Output	1 mA / A	0.5 mA / A	0.333 mA / A

Electrical specifications

- Current range:**
1 A AC .. 1,000 A AC
1 A AC .. 2,000 A AC
1 A AC .. 24,00 A AC
- Turns Ratio:**
1,000:1, 2,000:1, 3,000:1
- Output signal:**
1 mA / A AC (1 A for 1,000 A)
0.5 mA / A AC (1 A for 2,000 A)
0.333 mA / A AC (1 A for 3,000 A)
- Accuracy and phase shift ⁽¹⁾:**

1,000 A calibre:

Primary current:	50 A	200 A	1,000 A
Accuracy in % of output signal	3%	1.5%	1%
Phase shift	3°	1.5°	1°

Load impedance: 2.5 Ω

Overload: 1,400 A for 10 minutes

Ampere second product: 25 A.s

Accuracy: in accordance with IEC185-26-27, 2.5 VA, class 1 from 48 Hz to 1,000 Hz

- 2,000 A calibre:

Primary current:	100 A	400 A	2,000 A
Accuracy in % of output signal	1.5%	0.75%	0.5%
Phase shift	1.5°	0.75°	0.5°

Load impedance: 5 Ω

Overload: 2,400 A for 10 minutes

Ampere second product: 60 A.s

Accuracy: in accordance with IEC185-26-27, 5 VA, class 0.5 from 48 Hz to 1,000 Hz

- 3,000 A calibre:

Primary current:	150 A	600 A	3,000 A
Accuracy in % of output signal	1.5%	0.75%	0.5%
Phase shift	1.5°	0.75°	0.5°

Load impedance: 10 Ω

Overload: 3400 A for 10 minutes

Ampere second product: 90 A.s

Accuracy: in accordance with IEC185-26-27, 10 VA
Class 0.5 from 48 Hz to 1,000 Hz

- Bandwidth:**
30 Hz to 1,000 Hz (in continuous use above 600 Hz the max. measurement current is limited)
- Load impedance:**
< 10 Ω
- Operating voltage:**
600 V AC
- Common mode voltage:**
600 V AC
- Maximum output voltage (secondary open):**
Limited to 42 V peak max.
- Influence of adjacent conductor:**
0.005 A / A AC
- Influence of conductor position in jaws:**
1.5 % ± 0.2 A on the 1,000:1 ratio
1 % ± 0.2 A on the 2,000:1 ratio
1 % ± 0.2 A on the 3,000:1 ratio

Mechanical specifications

- Operating temperature:**
-10°C to +50°C
- Storage temperature:**
-25°C to +80°C
- Influence of temperature:**
< 0.1 % per 10 °K
- Max. jaw opening:**
90 mm
- Clamping capacity:**
Cable: Cable: 64mm
Group of wires: 50 x 135 mm - 64 x 100 mm
- Casing protection rating:**
IP20 in accordance with IEC 529
- Drop test:**
500 mm (IEC 68-2-32)
- Shock resistance:**
100 g, in accordance with IEC68-2-27
- Vibration resistance:**
10 / 55/10 Hz, 0.15 mm test in accordance with IEC68-2-6
- Self-extinguishing capability:**
Casing: UL94 V0
Jaws: UL94 V2
- Dimensions:**
120 x 315 x 48 mm
- Weight:**
1,200 g

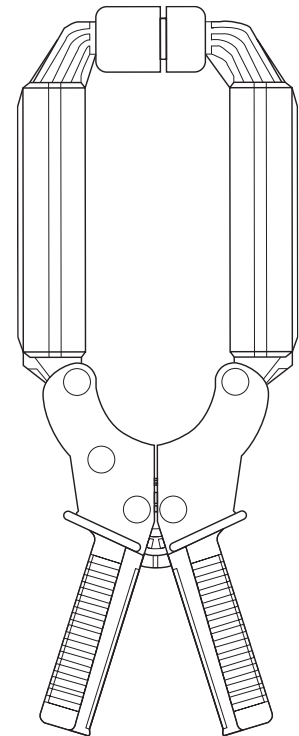

- Colour:**
Dark grey case with red jaws
- Output:**
2 safety sockets (4 mm)

Safety specifications

- Electrical safety:**
Double or reinforced insulation between the primary and secondary circuits and the outer casing in accordance with IEC 1010-2-032
- 600 V category III, pollution degree 2
- 300 V category IV, pollution degree 2
- Electromagnetic compatibility (EMC):**
EN 50081-1: class B
EN 50082-2:
- Electrostatic discharge: IEC 1000-4-2
- Radiated field: IEC 1000-4-3
- Fast transients: IEC 1000-4-4
- Magnetic field at 50/60Hz: IEC 1000-4-8

(1) Conditions of reference: 23 °C ± 5 °K, 20 % to 75 % RH, 48 Hz to 65 Hz, external magnetic field < 40 A/m, no DC component, no current-carrying conductor nearby, centred test sample.

To order	Reference
AC current clamp model D32N with operating manual	P01120051A

CURRENT CLAMPS FOR AC CURRENT

Model D33N

Current	2,400 A AC
Ratio	3,000:5
Output	1.666 mA / A

Electrical specifications

- Current range:**
1 A AC .. 2,400 A AC
(3,000 A for temperature < 35 °C)
- Turns Ratio:**
3,000:5
- Output signal:**
1.666 mA / A AC (5 A to 3,000 A)
- Accuracy and phase shift ⁽¹⁾:**

Primary current:	150 A	600 A	3,000 A
Accuracy in % of output signal	3%	1.5%	1%
Phase shift	3°	1.5°	1°

- Overload:**
3600 A for 10 minutes
- Accuracy:**
In accordance with IEC185-26-27, 5 VA class 1 from 48 Hz to 1,000 Hz
- Bandwidth:**
30 Hz to 5 kHz (in continuous use above 1 kHz the max. measurement current is limited)
- Ampere second product:**
90 A.s
- Load impedance:**
< 1 Ω
- Operating voltage:**
600 V AC
- Common mode voltage:**
600 V AC
- Maximum output voltage (secondary open):**
Limited to 42 V peak max.
- Influence of adjacent conductor:**
0.005 A / A AC
- Influence of conductor position in jaws:**
1% ± 0.1 A

Mechanical specifications

- Operating temperature:**
-10°C to +50°C
- Storage temperature:**
-25°C to +80°C
- Influence of temperature:**
< 0.1 % per 10 °K
- Max. jaw opening:**
90 mm
- Clamping capacity:**
Cable: Cable: 64mm
Group of wires: 50 x 135 mm - 64 x 100 mm
- Casing protection rating:**
IP20 in accordance with IEC 529
- Drop test:**
500 mm (IEC 68-2-32)
- Shock resistance:**
100 g, in accordance with IEC68-2-27
- Vibration resistance:**
10 / 55/10 Hz, 0.15 mm test in accordance with IEC68-2-6
- Self-extinguishing capability:**
Casing: UL94 V0
Jaws: UL94 V2
- Dimensions:**
120 x 315 x 48 mm
- Weight:**
1,200 g
- Colour:**
Dark grey case with red jaws
- Output:**
2 safety sockets (4 mm)

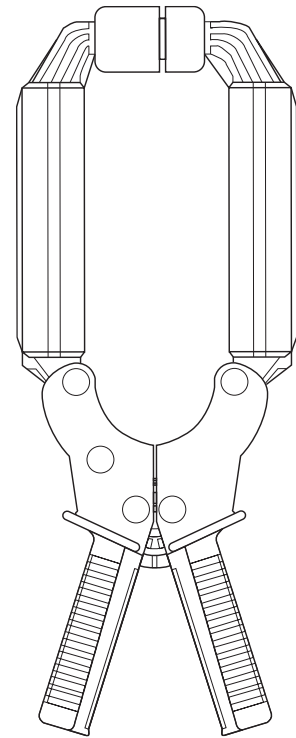

Safety specifications

- Electrical safety:**
Double or reinforced insulation between the primary and secondary circuits and the outer casing in accordance with IEC 1010-2-032
 - 600 V category III, pollution degree 2
 - 300 V category IV, pollution degree 2
- Electromagnetic compatibility (EMC):**
EN 50081-1: class B
EN 50082-2:
 - Electrostatic discharge: IEC 1000-4-2
 - Radiated field: IEC 1000-4-3
 - Fast transients: IEC 1000-4-4
 - Magnetic field at 50/60Hz: IEC 1000-4-8

(1) Conditions of reference: 23 °C ± 5 °K, 20 % to 75 % RH, 48 Hz to 65 Hz, external magnetic field < 40 A/m, no DC component, no current-carrying conductor nearby, centred test sample, load impedance 0.2 Ω

To order

AC current clamp model **D33N** with operating manual

Reference

P01120052A

CURRENT CLAMPS FOR AC CURRENT

Model D34N

Current	500 A AC	1,000 A AC	1,500 A AC
Ratio	500:5	1,000:5	1,500:5
Output	10 mA / A	5 mA / A	3.33 mA / A

Electrical specifications

- Current range:**
1 A AC .. 500 A AC
1 A AC .. 1,000 A AC
1 A AC .. 1,500 A AC
- Turns Ratio:**
500:5, 1,000:5, 1,500:5
- Output signal:**
10 mA / A AC (5 A for 500 A)
5 mA / A AC (5 A for 1,000 A)
3.33 mA / A AC (5 A for 1,500 A)
- Accuracy and phase shift ⁽¹⁾:**

- 500 A calibre:

Primary current:	25 A	100 A	500 A
Accuracy in % of output signal	5%	3%	3%
Phase shift	6°	4°	4°

Load impedance: 0.2 Ω

Overload: 700 A for 10 minutes

Ampere second product: 3.5 A.s

Accuracy: in accordance with IEC185-26-27, 5 VA

Class 3 from 48 Hz to 1,000Hz

- 1,000 A calibre:

Primary current:	50 A	200 A	1,000 A
Accuracy in % of output signal	3%	1.5%	1%
Phase shift	3°	1.5°	1°

Load impedance: 0.1 Ω

Overload: 1,400 A for 10 minutes

Ampere second product: 18 A.s

Accuracy: in accordance with IEC185-26-27, 5 VA,

class 1 from 48 Hz to 1,000 Hz

- 1,500 A calibre:

Primary current:	75 A	300 A	1,500 A
Accuracy in % of output signal	1.5%	0.75%	0.5%
Phase shift	1.5°	0.75°	0.5°

Load impedance: 0.1 Ω

Overload: 1,800 A for 10 minutes

Ampere second product: 40 A.s

Accuracy: in accordance with IEC185-26-27, 2.5 VA

Class 0.5 from 48 Hz to 1,000 Hz

- Bandwidth:**
30 Hz to 1,500 Hz (in continuous use above 1.5 kHz the max. measurement current is limited)
- Load impedance:**
< 1 Ω max
- Operating voltage:**
600 V AC
- Common mode voltage:**
600 V AC
- Maximum output voltage (secondary open):**
Limited to 42 V peak max.
- Influence of adjacent conductor:**
0.005 A / A AC
- Influence of conductor position in jaws:**
1.5 % ± 0.2 A on the 500:5 ratio
1 % ± 0.2 A on the 1,000:5 ratio
1 % ± 0.2 A on the 1,500:5 ratio

Mechanical specifications

- Operating temperature:**
-10°C to +50°C
- Storage temperature:**
-25°C to +80°C
- Influence of temperature:**
< 0.1 % per 10 °K
- Max. jaw opening:**
90 mm
- Clamping capacity:**
Cable: Cable: 64mm
Group of wires: 50 x 135 mm - 64 x 100 mm
- Casing protection rating:**
IP20 in accordance with IEC 529
- Drop test:**
500 mm (IEC 68-2-32)
- Shock resistance:**
100 g, in accordance with IEC68-2-27
- Vibration resistance:**
10 / 55/10 Hz, 0.15 mm test in accordance with IEC68-2-6
- Self-extinguishing capability:**
Casing: UL94 V0
Jaws: UL94 V2
- Dimensions:**
120 x 315 x 48 mm

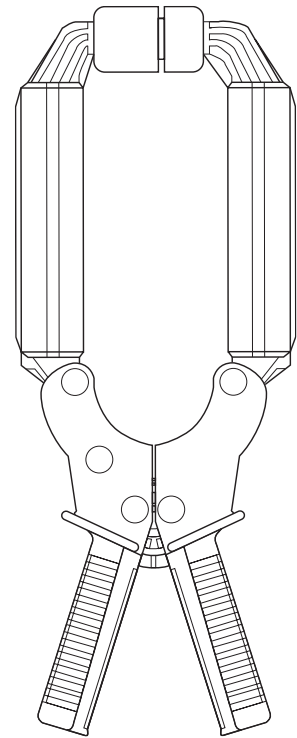

- Weight:**
1,200 g
- Colour:**
Dark grey case with red jaws
- Output:**
2 safety sockets (4 mm)

Safety specifications

- Electrical safety:**
Double or reinforced insulation between the primary and secondary circuits and the outer casing in accordance with IEC 1010-2-032
- 600 V category III, pollution degree 2
- 300 V category IV, pollution degree 2
- Electromagnetic compatibility (EMC):**
EN 50081-1: class B
EN 50082-2:
- Electrostatic discharge: IEC 1000-4-2
- Radiated field: IEC 1000-4-3
- Fast transients: IEC 1000-4-4
- Magnetic field at 50/60Hz: IEC 1000-4-8

(1) Conditions of reference: 23 °C ± 5 °K, 20 % to 75 % RH, 48 Hz to 65 Hz, external magnetic field < 40 A/m, no DC component, no current-carrying conductor nearby, centred test sample.

To order	Reference
AC current clamp model D34N with operating manual	P01120053A

CURRENT CLAMPS FOR AC CURRENT

Model D35N

Current	1,000 A AC	2,000 A AC	2,400 AAC
Ratio	1,000:5	2,000:5	3,000:5
Output	5 mA / A	2.5 mA / A	1.666 mA / A

Electrical specifications

- Current range:**
1 A AC .. 1,000 A AC
1 A AC .. 2,000 A AC
1 A AC .. 2,400 A AC
(3,000 A for temperature < 35 °C)
- Turns Ratio:**
1,000:5; 2,000:5; 3,000:5
- Output signal:**
5 mA / A AC (5 A for 1,000 A)
2.5 mA / A AC (5 A for 2,000 A)
1,666 mA / A AC (5 A for 3,000 A)
- Accuracy and phase shift ⁽¹⁾:**
1,000 A calibre:

Primary current:	50 A	200 A	1,000 A
Accuracy in % of output signal	3 %	1.5 %	1 %
Phase shift	3°	1.5°	1°

Load impedance: 0.1 Ω
Overload: 1,200 A for 10 minutes
Ampere second product: 15 A.s
Accuracy: in accordance with IEC185-26-27, 2.5 VA
Class 1 from 48 Hz to 1,000 Hz

- 2,000 A calibre:

Primary current:	100 A	400 A	2,000 A
Accuracy in % of output signal	1.5 %	0.75 %	0.5 %
Phase shift	1.5°	0.75°	0.5°

Load impedance: 0.2 Ω
Overload: 2,400 A for 10 minutes
Ampere second product: 50 A.s
Accuracy: in accordance with IEC185-26-27, 5 VA,
class 0.5 from 48 Hz to 1,000 Hz

- 3,000 A calibre:

Primary current:	150 A	600 A	3,000 A
Accuracy in % of output signal	1.5 %	0.75 %	0.5 %
Phase shift	1.5°	0.75°	0.5°

Load impedance: 0.4 Ω
Overload: 2,400 A for 10 minutes
Ampere second product: 80 A.s
Accuracy: in accordance with IEC185-26-27, 10 VA
Class 0.5 from 48 Hz to 1,000 Hz

- Bandwidth:**
30 Hz to 1,500 Hz (in continuous use above 1.5 kHz the max. measurement current is limited)
- Load impedance:**
< 2 Ω max
- Operating voltage:**
600 V AC
- Common mode voltage:**
600 V AC
- Influence of adjacent conductor:**
0.005 A / A AC
- Influence of conductor position in jaws:**
1.5 % ± 0.2 A on the 1,000:5 ratio
1 % ± 0.2 A on the 2,000:5 ratio
1 % ± 0.2 A on the 3,000:5 ratio

Mechanical specifications

- Operating temperature:**
-10°C to +50°C
- Storage temperature:**
-25°C to +80°C
- Influence of temperature:**
< 0.1 % per 10 °K
- Max. jaw opening:**
90 mm
- Clamping capacity:**
Cable: Cable: 64mm
Group of wires: 50 x 135 mm - 64 x 100 mm
- Casing protection rating:**
IP20 in accordance with IEC 529
- Drop test:**
500 mm (IEC 68-2-32)
- Shock resistance:**
100 g, in accordance with IEC68-2-27
- Vibration resistance:**
10 / 55/10 Hz, 0.15 mm test in accordance with IEC68-2-6
- Self-extinguishing capability:**
Casing: UL94 V0
Jaws: UL94 V2
- Dimensions:**
120 x 315 x 48 mm
- Weight:**
1,200 g

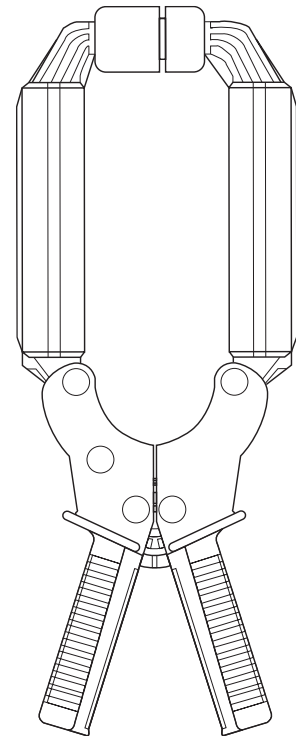

- Colour:**
Dark grey case with red jaws
- Output:**
2 safety sockets (4 mm)

Safety specifications

- Electrical safety:**
Double or reinforced insulation between the primary and secondary circuits and the outer casing in accordance with IEC 1010-2-032
- 600 V category III, pollution degree 2
- 300 V category IV, pollution degree 2
- Electromagnetic compatibility (EMC):**
EN 50081-1: class B
EN 50082-2:
- Electrostatic discharge: IEC 1000-4-2
- Radiated field: IEC 1000-4-3
- Fast transients: IEC 1000-4-4
- Magnetic field at 50/60Hz: IEC 1000-4-8

(1) Conditions of reference: 23 °C ± 5 °K, 20 % to 75 % RH, 48 Hz to 65 Hz, external magnetic field < 40 A/m, no DC component, no current-carrying conductor nearby, centred test sample.

To order	Reference
AC current clamp model D35N with operating manual	P01120054A

CURRENT CLAMPS FOR AC CURRENT

Model D36N

Current	3,000 A AC
Ratio	3,000:3
Output	1 mA / A

Electrical specifications

- Current range:**
1 A AC .. 2,400 A AC
- Turns Ratio:**
3,000:3
- Output signal:**
1 mA / A AC (3 A for 3,000 A)
- Accuracy and phase shift ⁽¹⁾:**

Primary current:	150 A	600 A	3,000 A
Accuracy in % of output signal	1.5% + 1 mA	0.75 %	0.5 %
Phase shift	1.5°	0.75°	0.5°

- Accuracy:**
In accordance with IEC185-26-27, 5 VA, class 0.5 from 48 Hz to 1,000 Hz
- Bandwidth:**
30 Hz to 5 kHz (beyond 400 Hz the output is limited in inverse proportion to the frequency)
- Overload:**
3600 A for 5 minutes
- Maximum output voltage (secondary open):**
Electronic protection circuit limiting voltage to 42 V peak max
- Load impedance:**
< 0.6 Ω
- Operating voltage:**
600 V AC
- Common mode voltage:**
600 V AC
- Influence of adjacent conductor:**
0.005 A / A AC
- Influence of conductor position in jaws:**
1 % ± 0.1 A

Mechanical specifications

- Operating temperature:**
-10°C to +50°C
- Storage temperature:**
-25°C to +80°C
- Influence of temperature:**
< 0.1 % per 10 °K
- Max. jaw opening:**
90 mm
- Clamping capacity:**
Cable: 64 mm
Group of wires: 50 x 135 mm - 64 x 100 mm
- Casing protection rating:**
IP20 in accordance with IEC 529
- Drop test:**
500 mm (IEC 68-2-32)
- Shock resistance:**
100 g, in accordance with IEC68-2-27
- Vibration resistance:**
10 / 55/10 Hz, 0.15 mm
test in accordance with IEC68-2-6
- Self-extinguishing capability:**
Casing: UL94 V0
Jaws: UL94 V2
- Dimensions:**
120 x 315 x 48 mm
- Weight:**
1,200 g
- Colour:**
Dark grey case with red jaws
- Output:**
Safety sockets (4mm)

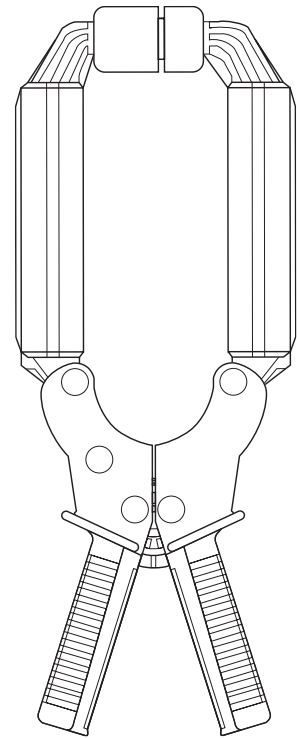

Safety specifications

- Electrical safety:**
Double or reinforced insulation between the primary and secondary circuits and the outer casing in accordance with IEC 1010-2-032
 - 600 V category III, pollution degree 2
 - 300 V category IV, pollution degree 2
- Electromagnetic compatibility (EMC):**
EN 50081-1: class B
EN 50082-2:
 - Electrostatic discharge: IEC 1000-4-2
 - Radiated field: IEC 1000-4-3
 - Fast transients: IEC 1000-4-4
 - Magnetic field at 50/60Hz: IEC 1000-4-8

(1) Conditions of reference: 23 °C ± 5 °K, 20 % to 75 % RH, 48 Hz to 65 Hz, external magnetic field < 40 A/m, no DC component, no current-carrying conductor nearby, centred test sample, load impedance 0.55 Ω.

To order	Reference
AC current clamp model D36N with operating manual	P01120055A

CURRENT CLAMPS FOR AC CURRENT

Model D37N

Current	30 A AC	300 A AC	3,000 A AC
Output	100 mV / A	10 mV / A	1 mV / A

Electrical specifications

- Current range:**
10 mA .. 30 A AC
1 A AC .. 300 A AC
1 A AC .. 2,000 A AC
(2,800 A for temperature < 35 °C)
- Output signal:**
100 mV / A AC (3 V for 30 A) 90 A peak
10 mV / A AC (3 V for 300 A) 900 A peak
1.666 mV / A AC (3 V for 3,000 A) 9,000 A peak
- Accuracy and phase shift (1):**

Primary current:	1.5 A	6 A	30 A
Accuracy in % of output signal	2% ± 10 mV		
Phase shift	15°	7°	5°

- 300 A calibre:

Primary current:	15 A	60 A	300 A
Accuracy in % of output signal	2% ± 2 mV		
Phase shift	3°	1.5°	1°

- 3,000 A calibre:

Primary current:	150 A	600 A	3,000 A
Accuracy in % of output signal	2% ± 0.5 mV		
Phase shift	1.5°	1°	0.5°

- Overload:**
3200 A for 5 minutes
- Ampere second product:**
100 A.s
- dV / dt:**
100 mV AC / A AC: dV / dt = 400 mV / μs
10 mV AC / A AC: dV / dt = 50 mV / μs
1 mV AC / A AC: dV / dt = 5 mV / μs
- Bandwidth:**
30 Hz to 5 kHz (on the 3,000 A range the max. measurement current is limited above 200 Hz)
- Load impedance:**
≥ 1 MΩ
- Operating voltage:**
600 V AC
- Common mode voltage:**
600 V AC
- Influence of adjacent conductor:**
0.005 A / A AC

- Influence of conductor position in jaws:**
1.5 % of the reading
- Influence of frequency:**
of 30 Hz to 5 kHz: ± 6 % on all calibres
- Influence of DC current:**
0.04 % per A DC

Mechanical specifications

- Operating temperature:**
-10°C to +50°C
- Storage temperature:**
-25°C to +80°C
- Influence of temperature:**
< 0.1 % per 10 °K
- Max. jaw opening:**
90 mm
- Clamping capacity:**
Cable: Cable: 64mm
Group of wires: 50 x 135 mm - 64 x 100 mm
- Casing protection rating:**
IP20 in accordance with IEC 529
- Drop test:**
500 mm (IEC 68-2-32)
- Shock resistance:**
100 g, in accordance with IEC68-2-27
- Vibration resistance:**
10 / 55/10 Hz, 0.15 mm test in accordance with IEC68-2-6
- Self-extinguishing capability:**
Casing: UL94 V0
Jaws: UL94 V2
- Dimensions:**
120 x 315 x 48 mm
- Weight:**
1,200 g
- Colour:**
Dark grey case with red jaws
- Output:**
2 safety sockets (4 mm)

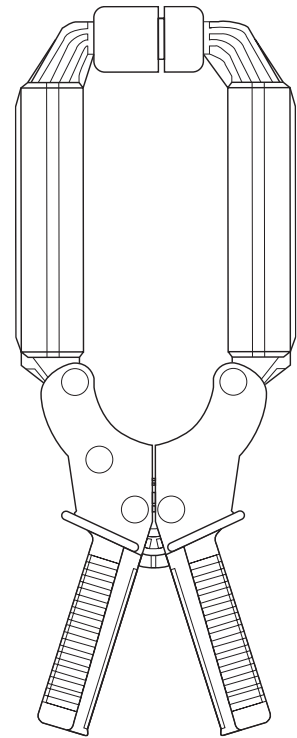

Safety specifications

- Electrical safety:**
Double or reinforced insulation between the primary and secondary circuits and the outer casing in accordance with IEC 1010-2-032
 - 600 V category III, pollution degree 2
 - 300 V category IV, pollution degree 2
- Electromagnetic compatibility (EMC):**
EN 50081-1: class B
EN 50082-2:
 - Electrostatic discharge: IEC 1000-4-2
 - Radiated field: IEC 1000-4-3
 - Fast transients: IEC 1000-4-4
 - Magnetic field at 50/60Hz: IEC 1000-4-8

(1) Conditions of reference: 23 °C ± 5 °K, 20 % to 75 % RH, 48 Hz to 65 Hz, external magnetic field < 40 A/m, no DC component, no current-carrying conductor nearby, centred test sample.

To order	Reference
AC current clamp model D37N with operating manual	P01120056A

CURRENT CLAMPS FOR AC CURRENT

Model D38N (insulated AC current probe)

Current	90 A peak	900 A peak	9,000 A peak
Output	10 mV / A	1 mV / A	0.1 mV / A

Description

The D38N offers accurate AC current measurement and a voltage output in mV allowing direct readings on oscilloscopes.

A switch with 3 positions on the handle can be used to select the ranges.

The wide opening of the jaws means they can be used on cables and small busbars.

Electrical specifications

- Current range:**
 - 1 A AC .. 30 A AC (90 A peak)
 - 1 A AC .. 300 A AC (900 A peak)
 - 1 A AC .. 2,400 A AC (9,000 A peak)
 - (3,000 A for temperature < 35 °C)
- Output signal:**
 - 10 mV / A AC (3 V for 30 A)
 - 1 mV / A AC (3 V for 300 A)
 - 0.1 mV / A AC (3 V for 3,000 A)
- Accuracy and phase shift ⁽¹⁾:**
 - 30 A calibre

Primary current:	1.5 A	6 A	30 A	36 A
Accuracy in % of output signal	2% ± 1 mV			
Phase shift	≤ 20°	≤ 10°	≤ 5°	≤ 5°

- 300 A calibre

Primary current:	15 A	60 A	300 A	360 A
Accuracy in % of output signal	2% ± 0.5 mV			
Phase shift	≤ 3°	≤ 1.5°	≤ 1°	≤ 1°

- 3,000 A calibre

Primary current:	150 A	600 A	3,000 A	3,600 A
Accuracy in % of output signal	2% ± 0.2 mV			
Phase shift	≤ 3°	≤ 1.5°	≤ 1°	≤ 1°

- Bandwidth:**
 - 10 Hz to 50 kHz (depending on current)
- Rise/fall time from 10 % to 90 %:**
 - 4 µs
- 10 % delay time:**
 - 0.3 µs
- Ampere second product:**
 - 30 A calibre: 30 A.s
 - 300 A calibre: 125 A.s
 - 3,000 A calibre: 180 A.s
- Insertion impedance (at 400 Hz / 10 kHz)**
 - 30 A calibre: < 0.1 mΩ / < 1 mΩ
 - 300 A calibre: < 0.1 mΩ / < 0.5 mΩ
 - 3,000 A calibre: < 0.1 mΩ / < 0.4 mΩ
- Maximum currents:**
 - I < 2,400 A permanent
 - 2,400 A .. 2,800 A for 10 minutes and then 30 minutes shutdown
 - 2,800 A .. 4,000 A for 5 minutes and then 30 minutes shutdown

- Output impedance:**
 - 30 A calibre: ≤ 130 Ω ± 15 %
 - 300 A calibre: ≤ 140 Ω ± 15 %
 - 3,000 A calibre: ≤ 140 Ω ± 15 %
- Influence of temperature:**
 - ≤ 0.2 % of output signal per 10 °K
- Influence of adjacent conductor:**
 - ≤ 5 mA/A at 50 Hz
- Influence of DC current < 10 % of rated calibre superimposed on the rated current:**
 - 0.05 % / A DC
- Influence of conductor position in jaws:**
 - ≤ 1% + 0.1 A at 50/60 Hz
- Influence of frequency ⁽²⁾:**
 - 30 A calibre: < 1 dB from 10 Hz .. 10 kHz
 - 300 A calibre: < 1 dB from 10 Hz .. 10 kHz
 - 3,000 A calibre: < 1 dB from 10 Hz .. 10 kHz

Mechanical specifications

- Max. jaw opening:**
 - 90 mm
- Clamping capacity:**
 - Cable: Ø max 64 mm
- Busbars:**
 - 5 busbars from 125 x 5 mm
 - 3 busbars from 100 x 10 mm
 - (busbars spaced by their thickness)
- Output:**
 - Coaxial cable 2 m long, terminated by an insulated BNC connector
- Dimensions:**
 - 310 x 120 x 48 mm
- Mass:**
 - 1,200 g
- Operating temperature:**
 - 10°C to +50°C
- Storage temperature:**
 - 25°C to +80°C
- Relative humidity for operation:**
 - 0 to 85 % RH with a linear decrease above 35 °C
- Operating altitude:**
 - 0 to 2,000 m
- Casing protection rating:**
 - IP 20 (IEC 529)
- Drop test:**
 - 0.5 m (IEC 68-2-32)
- Shock resistance:**
 - 100 g / 6 ms / half-period (IEC 68-2-27)
- Protection against impacts:**
 - IK04 0.5 J (EN 50102)
- Vibration resistance:**
 - 10/55/10 Hz, 0.15 mm (IEC 68-2-6)

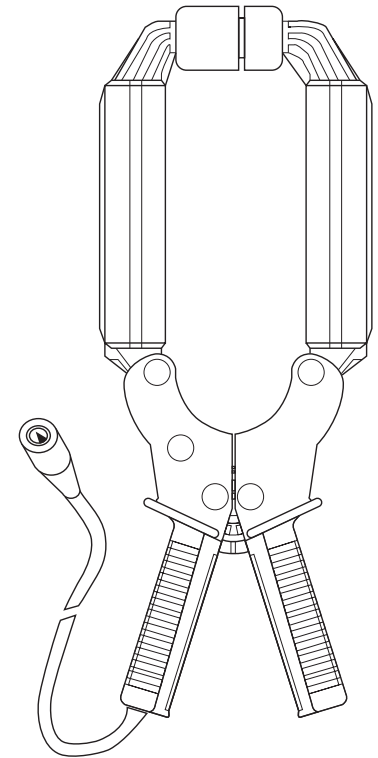

- Self-extinguishing capability:**
 - Handles: UL94 V0
 - Jaws: UL94 V2
- Colours:**
 - Dark grey handles with red jaws

Safety specifications

- Electrical safety:**
 - Instrument with double insulation or reinforced insulation between the primary, the secondary and the grippable part located under the guard as per IEC 1010-1 & IEC 1010-2-032
 - 600 V category III, pollution degree 2
 - 300 V category IV, pollution degree 2

CURRENT CLAMPS FOR AC CURRENT

Model D38N (insulated AC current probe)

Curves at 50 Hz

30 A calibre

Error on measurement

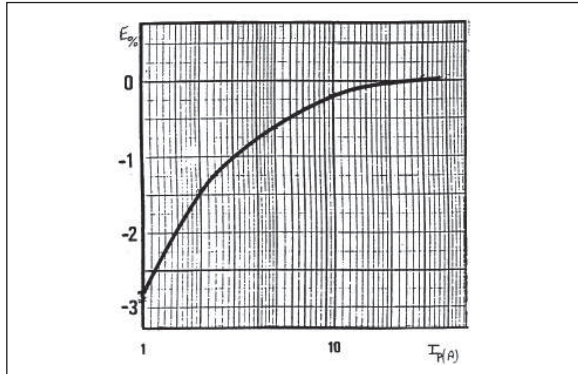

Phase shift

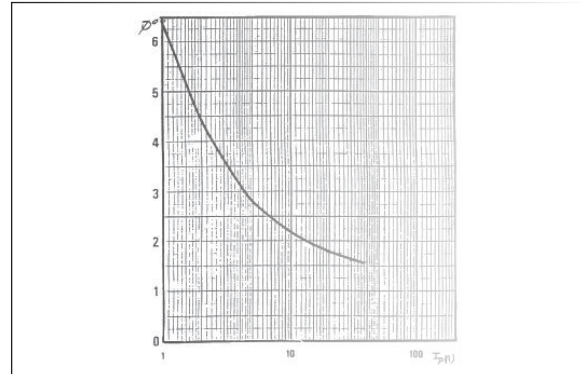

300 A calibre

Error on measurement

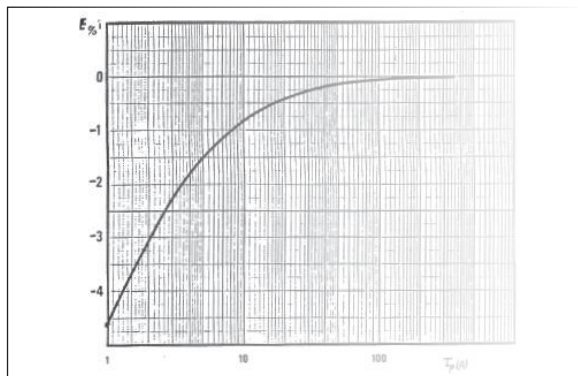

Phase shift

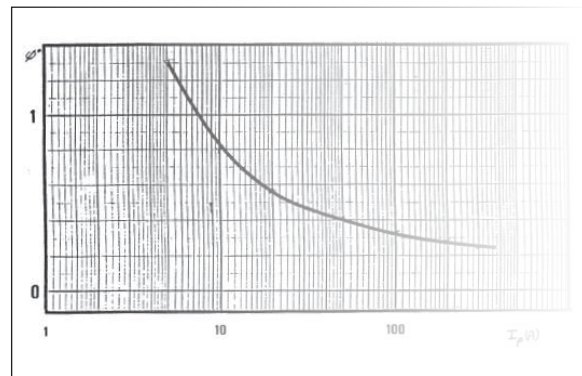

3,000 A calibre

Error on measurement

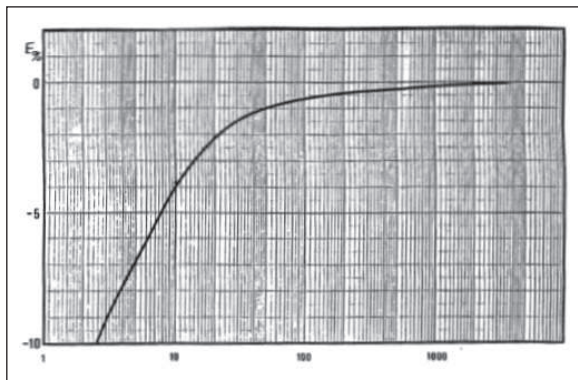

Phase shift

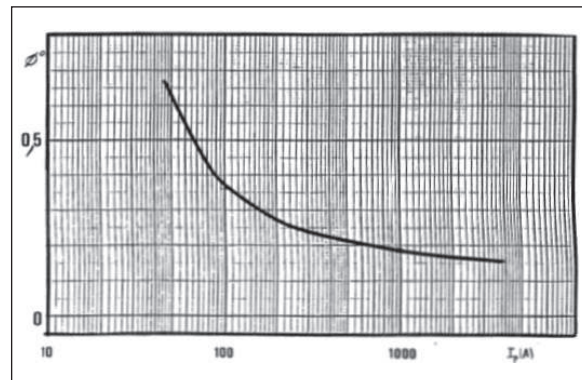

CURRENT CLAMPS FOR AC CURRENT

Model D38N (insulated AC current probe)

Frequency response

30 A calibre

I = 10 A

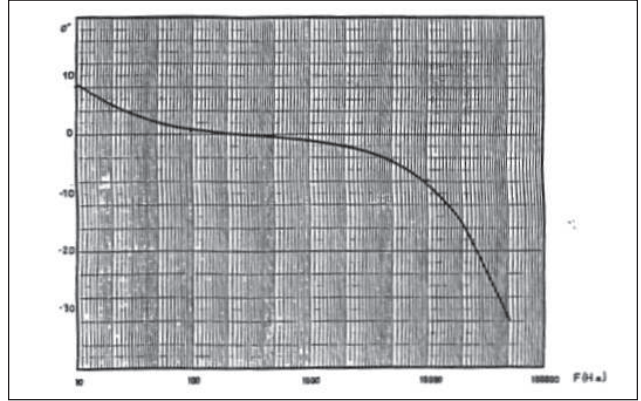
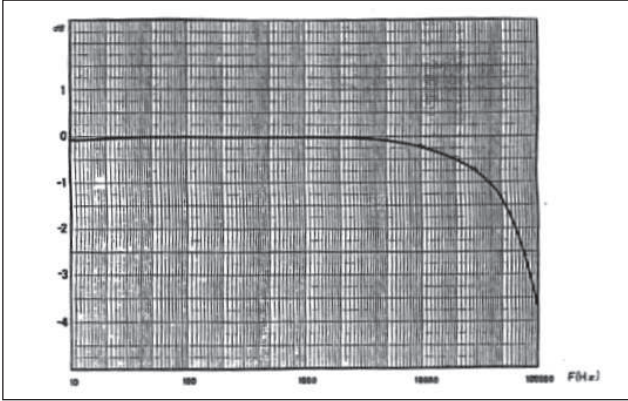

300 A calibre

I = 10 A

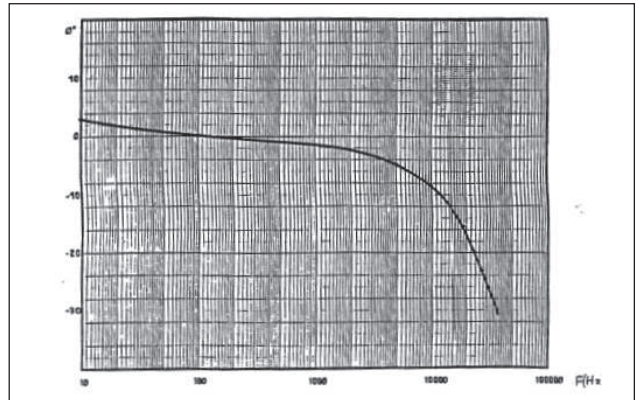
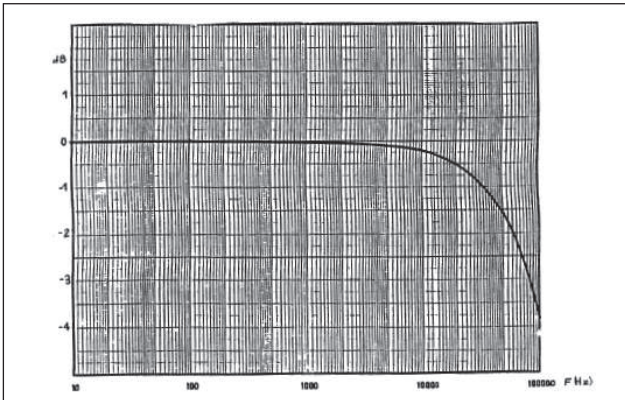

3,000 A calibre

I = 100 A

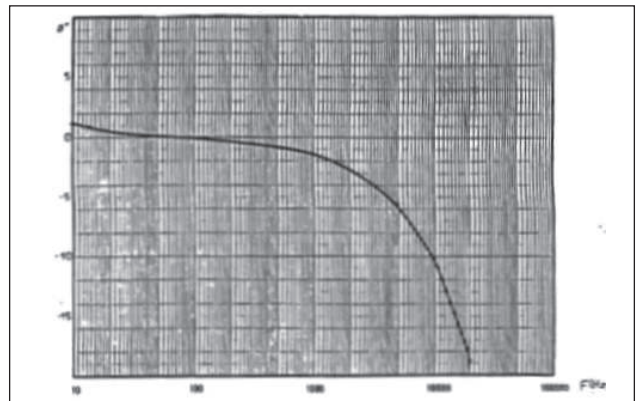
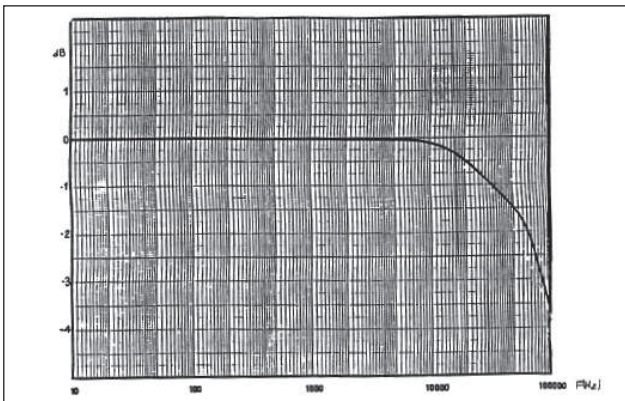

CURRENT CLAMPS FOR AC CURRENT

Model D38N (insulated AC current probe)

Response to a single step ($I_p = 1 \text{ A}$)

30 A calibre

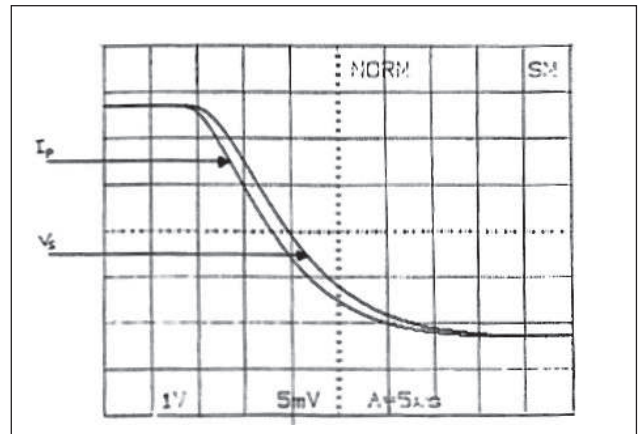
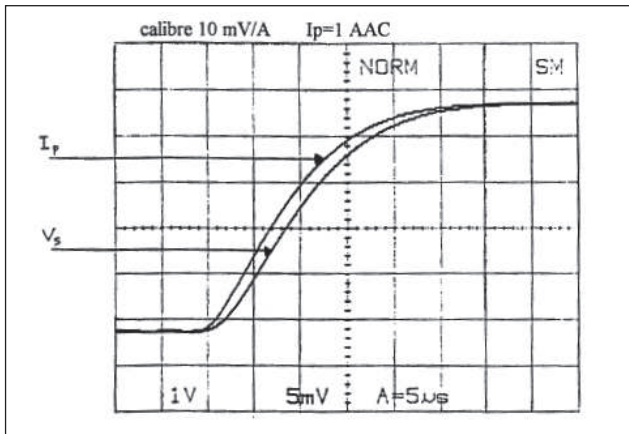

Response to a square signal ($I_p = 10 \text{ A}$)

30 A calibre

10 Hz

100 Hz

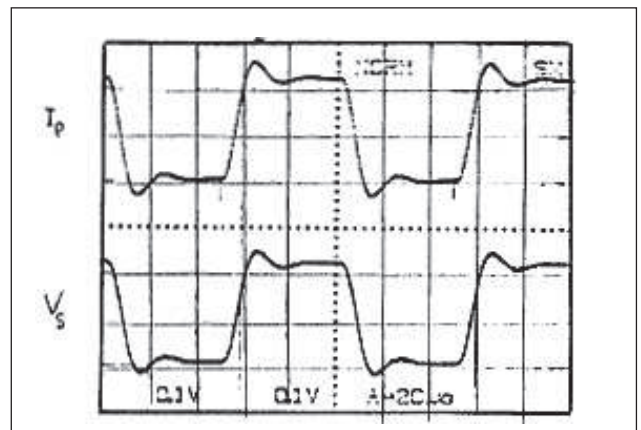
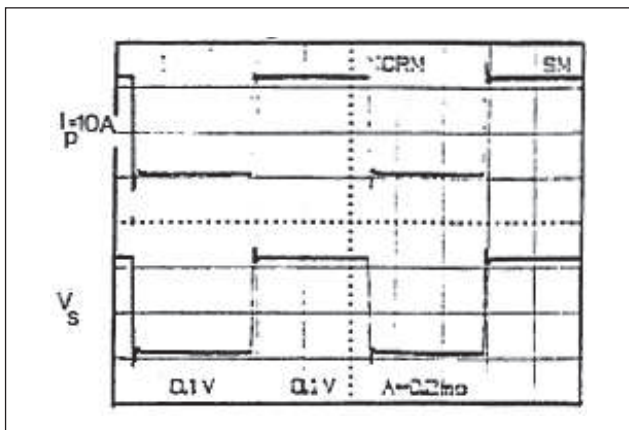
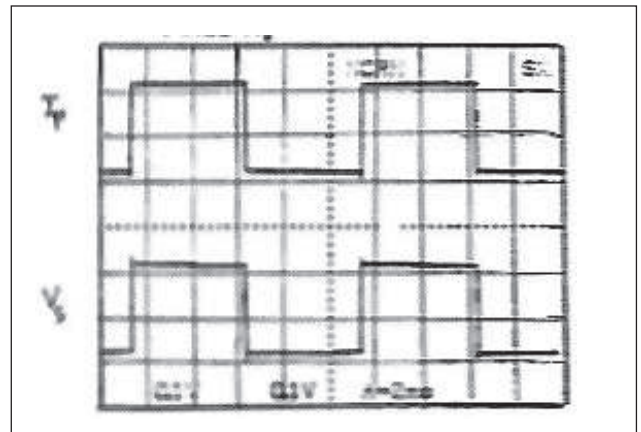
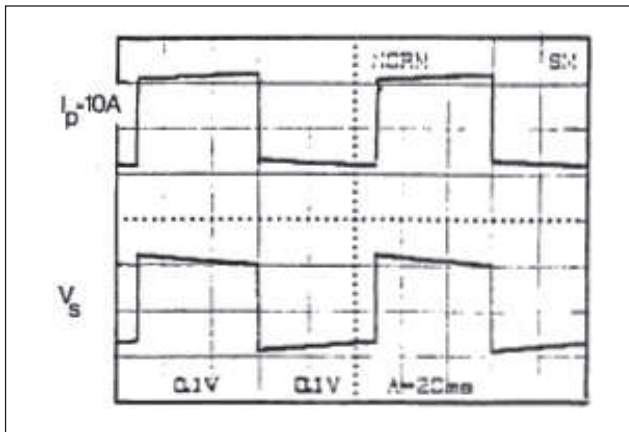

CURRENT CLAMPS FOR AC CURRENT

Model D38N (insulated AC current probe)

Influence of DC current superimposed on the signal

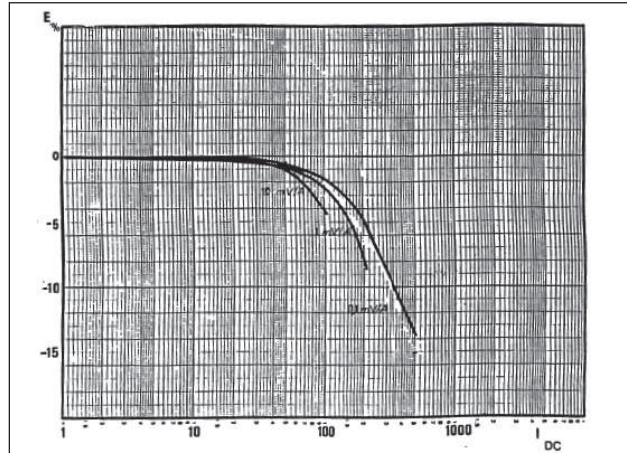

Maximum current according to frequency

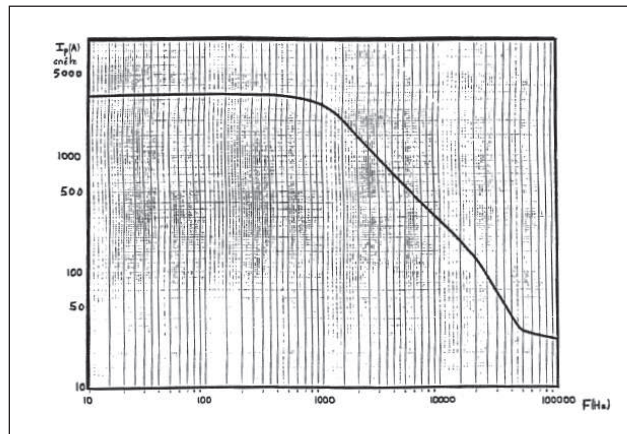

- (1) Conditions of reference: 23 °C ± 3 °K, 20 % to 75 % RH, sinusoidal signal with frequency of 48 Hz at 65 Hz, external magnetic field < 40 A/m, no DC components, no external conductor with circulating current, conductor centred for measurement, load impedance > 1 MΩ / < 47 pF.
- (2) Out of reference domain.

To order	Reference
AC current clamp model D38N with operating manual	P01120057A

NOTES

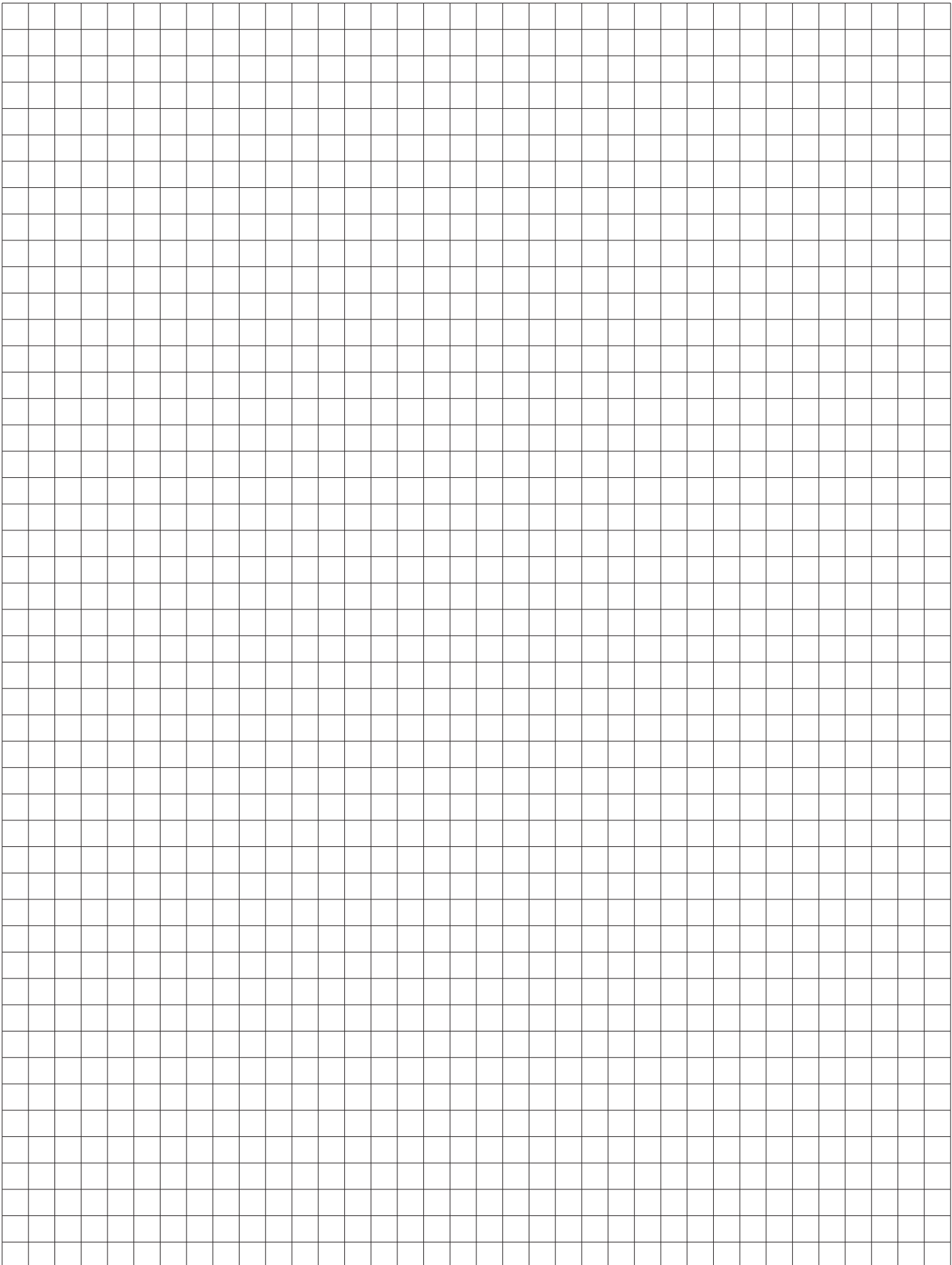

CURRENT CLAMPS FOR AC CURRENT



B series

The only model in the B series, the B102 is designed to measure earth leakage currents caused by insulation faults.

It enables the fault to be located and diagnosed before failure occurs thus avoiding installation shutdown.

It is designed specifically for locating low-current faults on high-current circuits.

The B102 measures differential or leakage current from 500 μA upwards and may be used to measure currents up to 400 A in continuous use (400 A max.). The B102 has 2 measurement ranges, 1 mV / mA or 1 mV / A.

As a leakage current detector, the B102 can be used on single or multiphase systems whether the currents are in or out of phase, balanced or unbalanced.

The B102 may be used simply as a high-precision clamp-on current probe.

With its 115 mm jaw opening and dynamic measurement range from 500 μA to 400 A, the B102 is a versatile instrument, highly useful in the analysis of unbalanced circuits, leakage currents and earth loop currents.

CURRENT CLAMPS FOR AC CURRENT

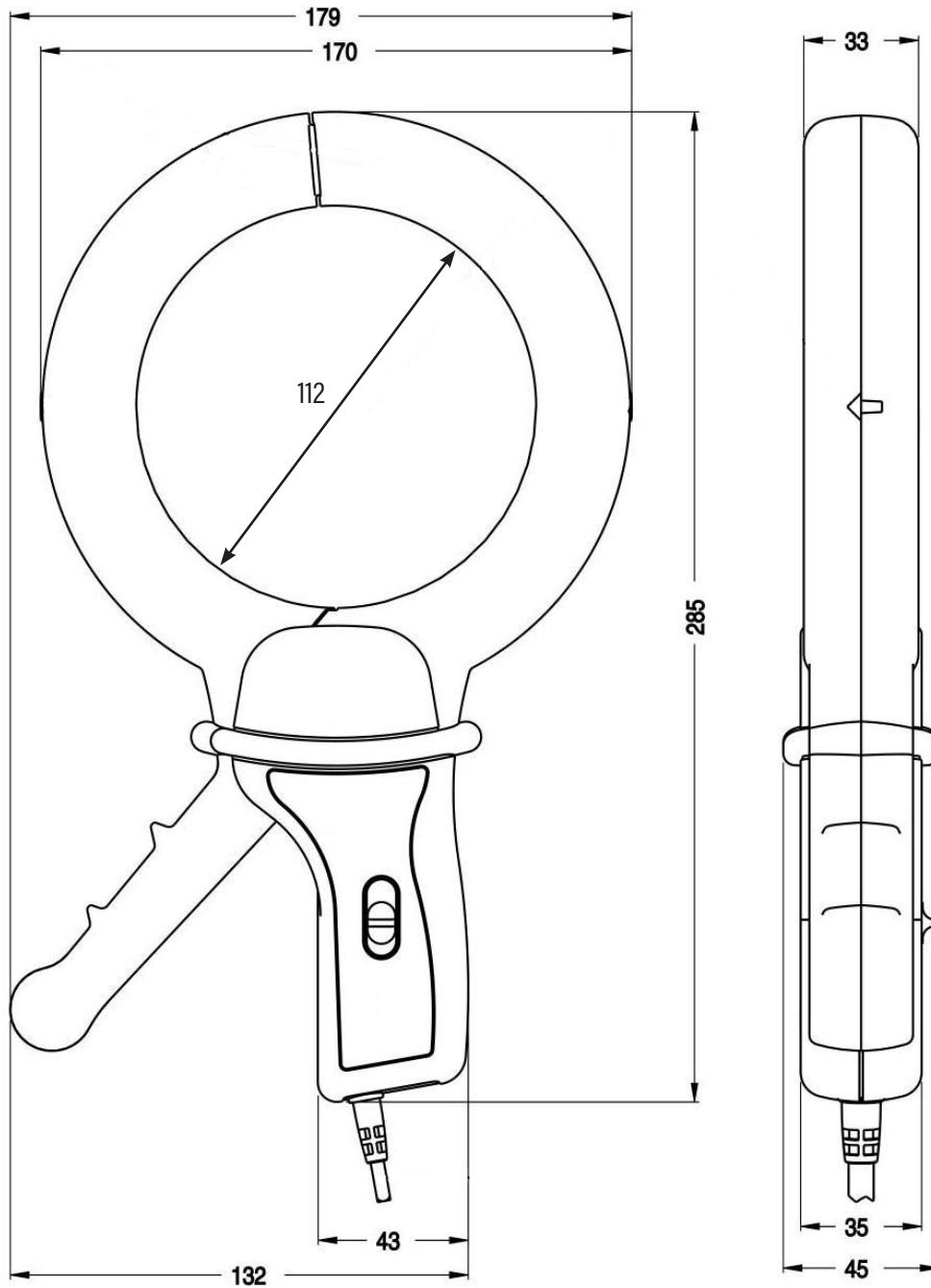

CURRENT CLAMPS FOR AC CURRENT

Model B102 (probe for leakage currents)

Current	4 A AC	400 A AC
Output	1 mV / mA	1 mV / A

Description

The B102 clamp measures leakage currents or residual currents as low as 500 μ A and can be used with multimeters equipped with a calibre in mV AC.

The B102 clamp measures the currents flowing in earth loops as well as leakage currents. It can be used on live installations to detect insulation faults on the earth circuits of single and three-phase networks.

Electrical specifications

- Current range:**
0.5 mA AC .. 4 A AC
0.5 A AC .. 400 A AC
- Output signal:**
1 mV AC / mA AC (4 V for 4 A)
1 mV AC / A AC (0.4 V for 400 A)
- Accuracy and phase shift ⁽¹⁾:**

Calibre	4 A		
Primary current:	0.5 mA .. 10 mA	10 mA .. 100 mA	100 mA .. 4 A
Accuracy in % of output signal	$\leq 3\% + 1\text{ mV}$	$\leq 0.5\% + 0.5\text{ mV}$	$\leq 0.5\% + 0.5\text{ mV}$
Phase shift	Not specified	$\leq 15^\circ$	$\leq 10^\circ$

Calibre	400 A		
Primary current:	0.5 mA .. 10 A	10 A .. 200 A	200 A .. 400 A
Accuracy in % of output signal	$\leq 0.5\% + 0.5\text{ mV}$	$\leq 0.35\% + 0.5\text{ mV}$	$\leq 0.35\% + 0.5\text{ mV}$
Phase shift	Not specified	$\leq 1^\circ$	$\leq 0.7^\circ$

- Bandwidth:**
30 Hz .. 1 kHz (depending on current value)
- Maximum currents:**
400 A AC continuous for a frequency ≤ 1 kHz
Peak current < 1,000 A
- Load impedance:**
 $\geq 10\text{ M}\Omega / 100\text{ pF}$
- Max. voltage output:**
Electronic protection circuit limiting voltage to 6 V peak max.
- Influence of temperature:**
Measurement: $\leq 100\text{ ppm / K}$ or 0.1 % of output signal per 10 °K
- Influence of adjacent conductor:**
0.4 mA/A typical at 50 Hz
- Influence of an external field:**
For a perpendicular external field of 400 A/m at 50 Hz
 - 4 A calibre: $\leq 60\text{ mA}$
 - 400 A calibre: $\leq 0.1\text{ A}$
- Influence of conductor position in jaws:**
 $\leq 0.1\%$ of the reading at 50/60 Hz (non-residual current)
 $\leq 0.2\%$ of the reading at 50/60 Hz (residual current)
- Influence of DC current superimposed on rated current AC:**
for a current DC from 1 A
 - 4 A calibre: $\leq 1\text{ mA}$
 - 400 A calibre: $\leq 0.1\text{ A}$
- Influence of frequency:**
 - 4 A calibre: $\leq 2\%$
 - 400 A calibre: $\leq 0.5\%$ from 30 Hz to 1 kHz (limited to 100 A for 1 kHz)
- Influence of the measurement instrument's input impedance (Z_e):**
 - 4 A calibre: $E\% = [Z_e / (Z_e + 4.8) - 1] * 100$
 - 400 A calibre: $E\% = [Z_e / (Z_e + 0.0048) - 1] * 100$

Mechanical specifications

- Operating temperature:**
-10°C to +55°C
- Storage temperature:**
-40°C to +70°C
- Clamping capacity:**
Cables: $\varnothing 12\text{ mm}$
Busbars: 1 busbar 20 x 50 mm
- Casing protection rating:**
IP40 with clamp closed (NF EN60529 Ed. 95)
IP30 with jaws open
- Relative humidity for operation:**
0 to 85 % RH with a linear decrease above 35 °C
- Operating altitude:**
0 to 2,000 m

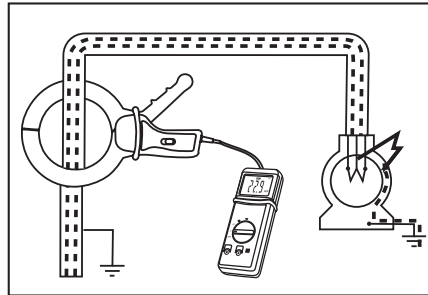

- Drop test:**
1 m (NF EN61010-2-032)
- Self-extinguishing capability:**
Casing: V0 according to UL94
Jaws: V2 according to UL94
- Dimensions:**
285 x 175 x 43 mm
- Mass:**
Approximately 1.3 kg
- Colours:**
Dark grey case with red jaws
- Output:**
Cable with double insulation, length 1.5 m, terminated by 2 insulated elbowed

Safety specifications

- Electrical safety:**
Instrument with double insulation or reinforced insulation between the primary, the secondary and the grippable part located under the guard as per EN 61010-1 Ed. 2: 2001, EN 61010-2-031 Ed. 2002 & EN 61010-2-032 Ed. 2003
 - 600 V category III, pollution degree 2
 - 300 V category IV, pollution degree 2
- Electromagnetic compatibility:**
EN 50081-1: class B
EN 50082-2:
 - CE-certified equipment compliant with standard EN61326-1 (Ed. 97) + A1 (Ed. 98) + A2 (Ed. 01)
 - Emission: stipulations for class B equipment (domestic use).
 - Immunity: regulations for equipment operated intermittently on industrial sites.

CURRENT CLAMPS FOR AC CURRENT

Model B102 (probe for leakage currents)

Curves at 50 Hz

4 A calibre

Linearity for AC

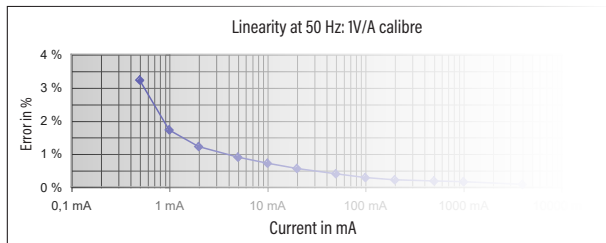

400 A calibre

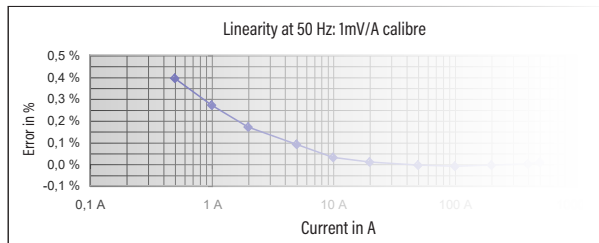

Phase shift

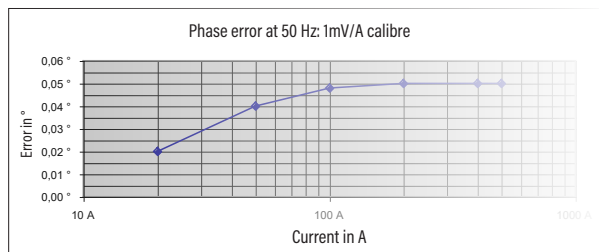
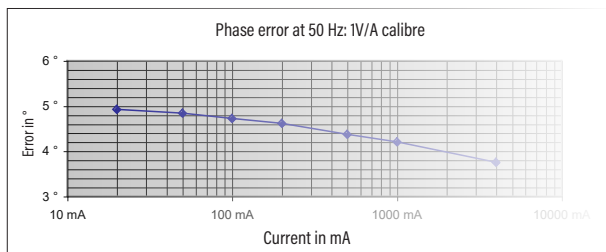

Frequency response

4 A calibre

Typical error on measurement

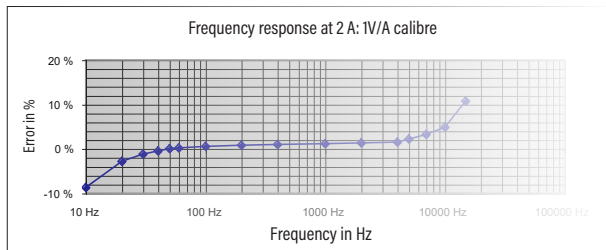

400 A calibre

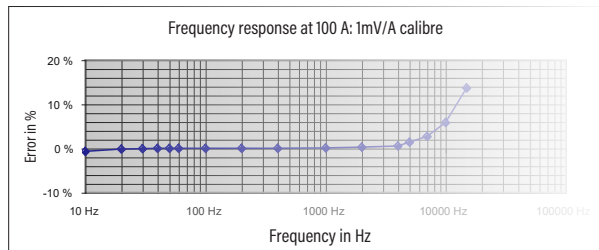

Typical phase shift

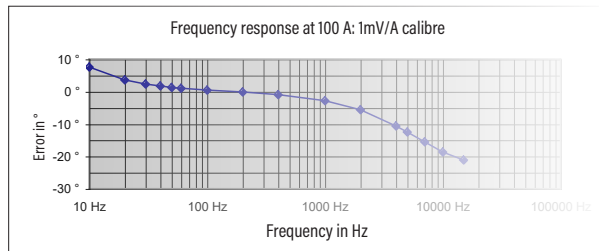
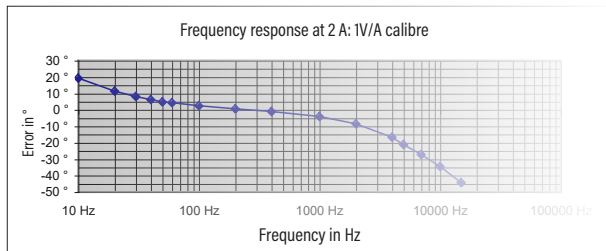

(1) Conditions of reference: 23 °C ± 3 °K, 20 % to 75 % RH, sinusoidal signal from frequency of 48 to 65 Hz, distortion factor < 1 %, no DC components, external magnetic field < 40 A/m, no AC magnetic field, no external conductor with circulating current, conductor centred for measurement, load impedance ≥ 10 MΩ / ≤ 100 pF.

To order	Reference
AC current clamp model B102 with operating manual	P01120083

FLEXIBLE PROBES FOR AC CURRENT



MiniFlex series

Making use of the principle of Rogowski coils, the MiniFlex models are flexible sensors offering a wide dynamic range for measuring AC currents and viewing high-speed current pulses.

The sensor's output voltage is proportional to the derivative of the current measured in the conductor and requires an electronic system for formatting.

The absence of a magnetic core at the centre of the coil brings several advantages:

- flexibility and light weight
- excellent response to rapid current changes, as it is not possible for induced Fourier currents to occur, so they do not increase the sensor's response time.
- excellent linearity due to the absence of core saturation even when there are very high current, as in the case of electric power transmission, electrical welding or applications involving high-power pulses.

The great care taken when manufacturing our sensors means they benefit from particularly homogeneous winding, with equidistant turns along the whole length of the sensor, thus ensuring good immunity against electromagnetic interference.

The MiniFlex models are made up of a flexible sensor connected to a casing containing processing electronics which outputs a voltage with the same amplitude and form as the current measured.

• MiniFlex MA110 series:

With their small diameter and size, the sensors in the MA110 series are ideal for measuring currents in the electrical cabinets of residential or tertiary buildings or in low-power cabinets in industry. The rugged click together system benefits from IP67 ingress protection.

Available with "banana" or "BNC" connection technology, the MA110 series can be connected directly to a multimeter, a wattmeter or a logger for RMS measurements at the standard industrial frequencies. The casing offers 4 measurement calibres.

• MiniFlex MA130:

The MA130 sensor, part of the same series as the MA110, can be used to measure currents on three-phase installations. It is equipped with BNC connections with adapters for banana plugs. The processing unit offers 3 measurement calibres. The rugged click-together system has IP67 ingress protection. It can be connected to the AC voltage inputs (mV AC, AC) of any power analyser, logger or other measuring instrument.

• MiniFlex MA200 series:

The MA200 series is a family of "high-frequency" sensors specially designed for viewing and measuring electrical or electro-technical signals with wide variations and high amplitude. These "insulated current probes for oscilloscopes" offer a bandwidth of 1 MHz and can be used to analyse currents with complex forms, transients present in electronic power supplies, welding units, etc.

FLEXIBLE PROBES FOR AC CURRENT

MA110 - MA130 series

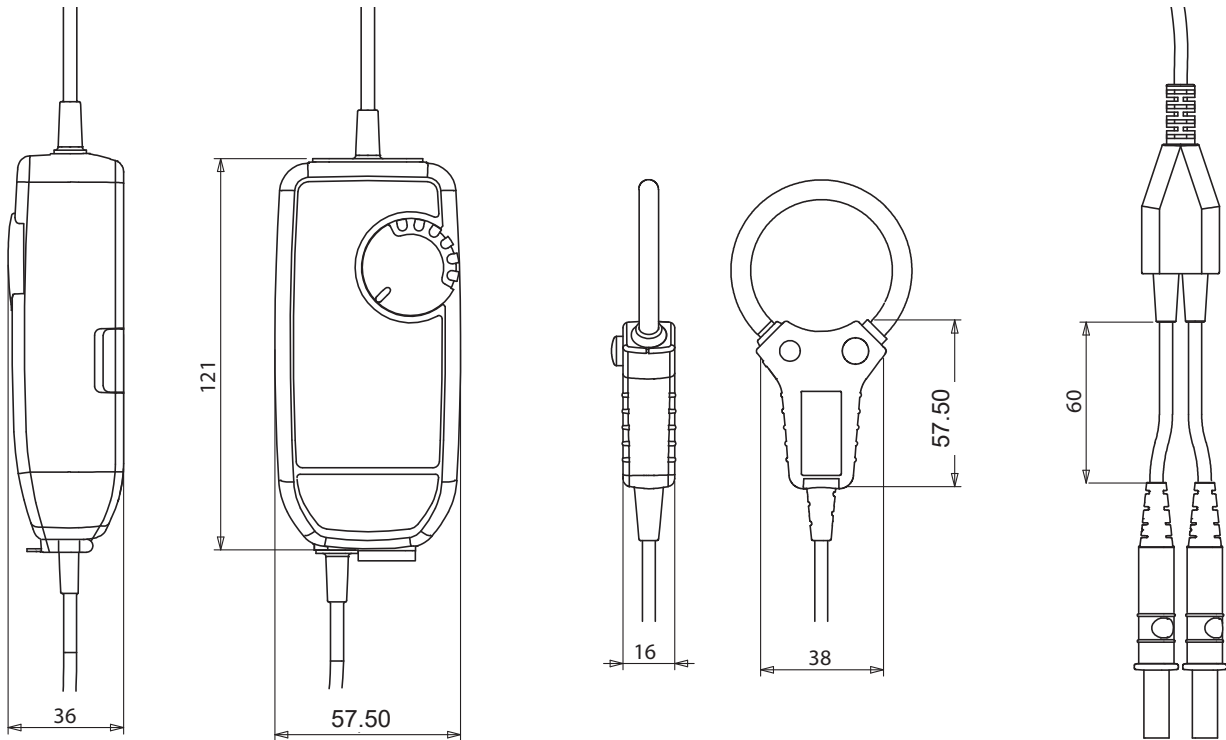

MA200 series

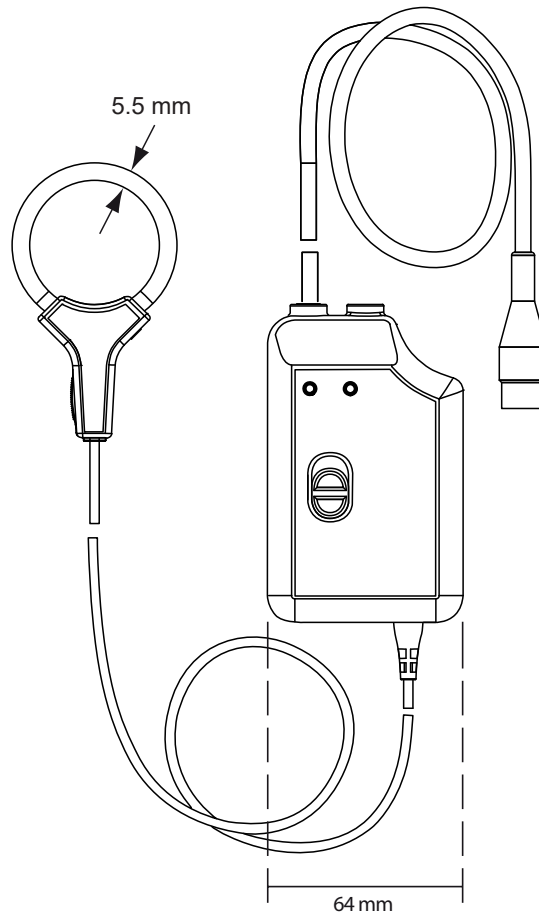

FLEXIBLE PROBES FOR AC CURRENT

Model MA110 3-30-300-3,000/3

Current	3 A AC	30 A AC	300 A AC	3,000 A AC
Output	1 mV/mA	100 mV/A	10 mV/A	1 mV/A

Description

The model MA110 MiniFlex sensor is a flexible sensor comprising an active part (Rogowski coil) linked to a casing containing electronics.

Unlike a current clamp with magnetic circuits, the MiniFlex models are flexible and are not subject to magnetic saturation constraints, so they offer excellent linearity, low phase shift and a large dynamic range for measurement (up to several kA) while remaining easy to use. The sensors' flexibility makes it simple to clamp and measure any conductor, whatever its type (cable, busbar, strand, etc. and accessibility). The design of the click-together opening and closing system means it can be handled with protective gloves.

The MA110 MiniFlex sensor can be connected to the AC voltage input of any multimeter with \varnothing 4 mm female plugs.

The MiniFlex MA110 model can be powered by batteries or by a standard external power supply. If the power supply fails, the instrument's batteries take over.

To maximize the battery life, the MiniFlex MA110 model has an automatic standby system which can be deactivated at start-up to perform long-term measurement campaigns.

The MiniFlex MA110 model has 3 green, yellow and red LEDs indicating, respectively, the power supply status, the status of the automatic standby function and any overruns of the measurement capacity.



Specifications for current measurement ⁽¹⁾

Calibre (I_N)	3 A	30 A	300 A	3,000 A
Measurement range in use	0.08 .. 3 A AC	0.5 .. 30 A AC	0.5 .. 300 A AC	0.5 .. 3,000 A AC
Specified measurement range	0.5 .. 3 A AC	2 .. 30 A AC	5 .. 300 A AC	50 .. 3,000 A AC
Output/input ratio	1 V/A (1 mV / mA)	100 mV / A	10 mV / A	1 mV / A
Bandwidth at -3 dB	10 Hz .. 10 kHz	10 Hz .. 20 kHz	10 Hz .. 20 kHz	10 Hz .. 20 kHz
Frequency limitation	Null	Null	Null	See curve
Intrinsic uncertainty	$\leq 1\% + 40 \text{ mV}$	$\leq 1\% + 4 \text{ mV}$	$\leq 1.5\% + 0.4 \text{ mV}$ ($I < 10\% I_N$) $\leq 1\% + 0.4 \text{ mV}$ ($I \geq 10\% I_N$)	$\leq 1.5\% + 0.04 \text{ mV}$ ($I < 10\% I_N$) $\leq 1\% + 0.04 \text{ mV}$ ($I \geq 10\% I_N$)
Phase shift at 50 Hz	$\leq 1^\circ$ (0.5° typical)	$\leq 1^\circ$ (0.5° typical)	$\leq 1^\circ$ (0.5° typical)	$\leq 1^\circ$ (0.5° typical)

Electrical specifications ⁽¹⁾

- Operating voltage:**
600 V_{RMS} (Cat. IV)
1,000 V_{RMS} (Cat. III)
- Battery:**
Two 1.5 V batteries (NEDA 15A, IEC LR6, AA)
+5 V DC via a μ USB Type B connector
- Battery life ⁽²⁾:**
300 hours typical
1,800 10-minute approx. measurements
- Consumption:**
10 μ A (OFF position)
90 μ A (sleep mode)
- Battery level indication:**
Flashing green LED (batteries voltage > 2 V)
- Influence of battery voltage:**
 $\leq 0.1\%$ (0.02 % typical) from 3.1 V to 2 V
- Influence of temperature:**
 $\leq 0.5\%$ (0.15 % typical) of output signal per 10 °K
- Influence of relative humidity:**
 $\leq 0.5\%$ (0.2 % typical) of output signal
- Influence of conductor position in the sensor ⁽³⁾:**
 $\leq 2.5\%$ (1 % typical)
- Influence of sensor deformation ⁽⁴⁾:**
 $\leq 1\%$ (0.2 % typical)
- Influence of adjacent conductor ⁽⁵⁾:**
 $\leq I_{ADJ} \times 1\%$ (2 % near click-lock system)
(0.2 % typical)
- Input impedance of the measuring instrument:**
 $\geq 1 \text{ M}\Omega$
- Common mode rejection ⁽⁶⁾:**
 $\leq 80 \text{ dB}$ (100 dB typical)
- Influence of the measurement instrument's impedance Z:**
 $\leq 0.1\%$ at 10 k Ω

FLEXIBLE PROBES FOR AC CURRENT

Model MA110 3-30-300-3,000/3

Mechanical specifications ⁽¹⁾

- Clamping capacity:**
Model length 170 mm: Ø max 45 mm
Model length 250 mm: Ø max 70 mm
Model length 350 mm: Ø max 100 mm
- Bending radius:**
≥ 20 mm
- Operating temperature:**
-10°C to +55°C
- Storage temperature:**
-40°C to +70°C
- Max. temperature of clamped conductor (measured):**
90 °C for 10 minutes max.
- Relative humidity for operation:**
0 to 85 % RH with a linear decrease above 35 °C
- Operating altitude:**
0 to 2,000 m
- Casing protection rating (leakproofing):**
Intermediate casing: IP54
Flexible sensor: IP 67
According to IEC 60529 Ed. 2.2-2013
- Drop test:**
1 m
- Self-extinguishing capability:**
Casing: UL94-V0
Sensor: UL94 V0
- Dimensions:**
Intermediate casing: 120 x 55 x 39 (overall)
Length of intermediate cable linking the sensor/ processing unit: 2 m
Length of output cable: 0.5 m
Ø of sensor: 6 mm
Connection cable Ø: 4 mm
- Weight:**
Model length 170 mm: 300 g
Sensor: 5 g / 10 cm
- Colours:**
Sensor: red
Sensor closing system: dark grey
Intermediate casing: Dark grey
- Output:**
Two-wire cable with reinforced or double insulation terminated by 2 red and black isolated male banana plugs Ø 4 mm

Safety specifications

- Electrical safety:**
Class II equipment with double or reinforced insulation between the primary and the secondary (winding connected to the connection cable) as per EN 61010-1 and 61010-2-032 Ed. 03-2012:
 - Sensor:
Type B
600 V Cat. IV / 1,000 V Cat. III, pollution degree 2
 - Intermediate casing:
600 V Cat. IV between the terminals and the external enclosure of the casing
- Electromagnetic compatibility (EMC) :**
Complies with the industrial environments according to EN 61326-1 Ed. 02-2012:
 - Immunity to radiated fields: at 3 V/m, error ≤ 5% of measuring range (criterion A)

3,000 A calibre

Frequency limitation according to amplitude

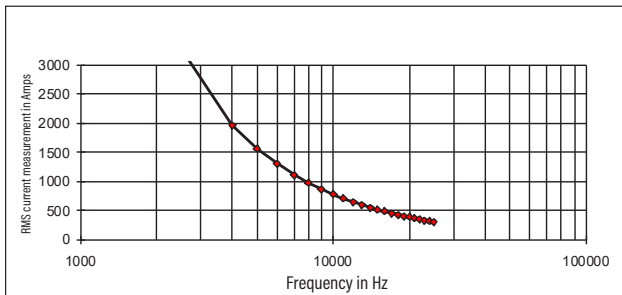

- (1) Conditions of reference: 23 °C ± 5 °K, 20 % to 75 % RH
Battery voltage 3.2 V ± 0.1 VDC
Frequency and form of signal measured: 30 to 440 Hz sinusoidal
Continuous magnetic field < 40 A/m
Absence of external AC magnetic field
Absence of external electrical field
Measured conductor centred in the circular sensor (coil) after operation for 1 minute
Measurement instrument input impedance ≥ 1 MΩ
- (2) With 3,000 mA/h batteries, for a supplied voltage between 3.2 V and 1.8 V (1.6 V to 0.9 V per battery), giving an average voltage of 2.8 V
- (3) Whatever the conductor's position within the loop, as long as the sensor is not distorted (circular sensor)
- (4) Oblong shape
- (5) Adjacent conductor carrying an AC current I_{adj} , in contact with the sensor
- (6) For a 600 V voltage applied between the enclosure and the secondary

To order	Reference
MiniFlex MA110 3-30-300-3,000 A / 3 V, sensor length 170 mm, Output via cable terminated by 2 x Ø 4 mm isolated male banana plugs	P01120660
MiniFlex MA110 3-30-300-3,000 A / 3 V, sensor length 250 mm, Output via cable terminated by 2 x Ø 4 mm isolated male banana plugs	P01120661
MiniFlex MA110 3-30-300-3,000 A / 3 V, sensor length 350 mm, Output via cable terminated by 2 x Ø 4 mm isolated male banana plugs	P01120662

FLEXIBLE PROBES FOR AC CURRENT

Model MA110 3-30-300-3,000/3

Frequency response

3 A calibre

Typical error on measurement according to frequency for a current of 2 A

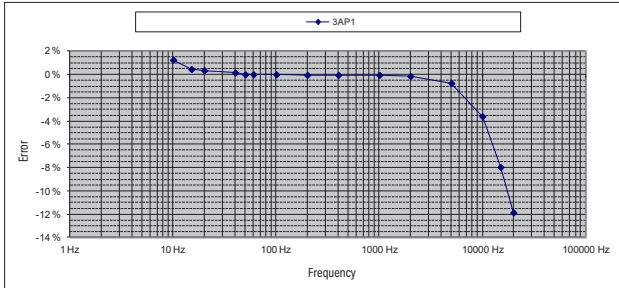

Typical phase shift according to frequency for a current of 2 A

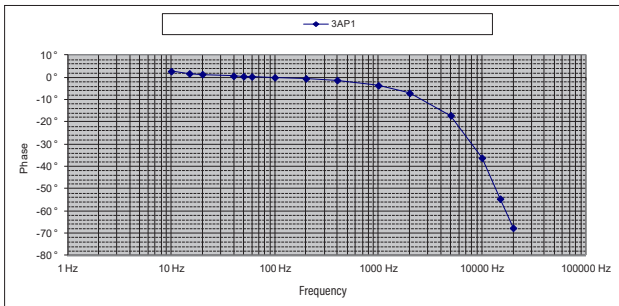

30 A calibre

Typical error on measurement according to frequency for a current of 20 A

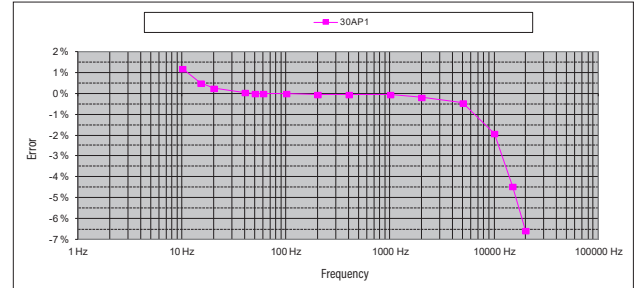

Typical phase shift according to frequency for a current of 20 A

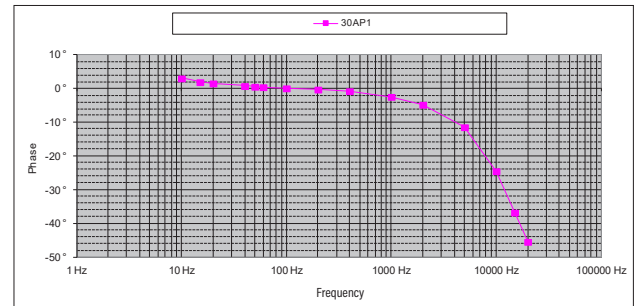

300 A calibre

Typical error on measurement according to frequency for a current of 20 A

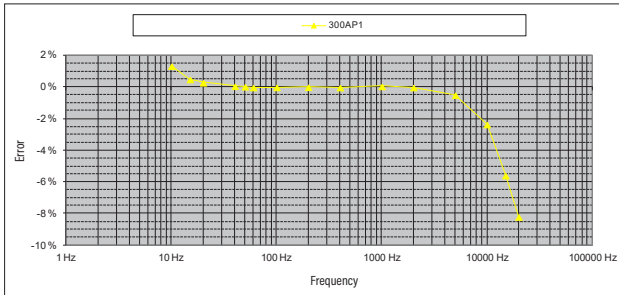

Typical phase shift according to frequency for a current of 20 A

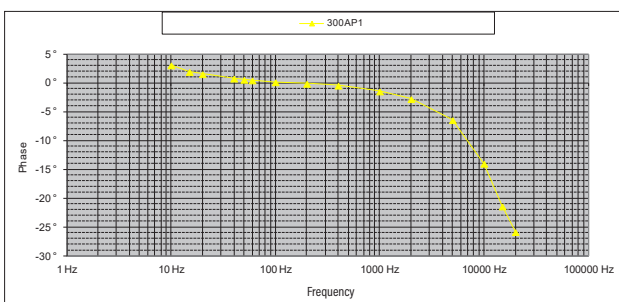

3,000 A calibre

Typical error on measurement according to frequency for a current of 20 A

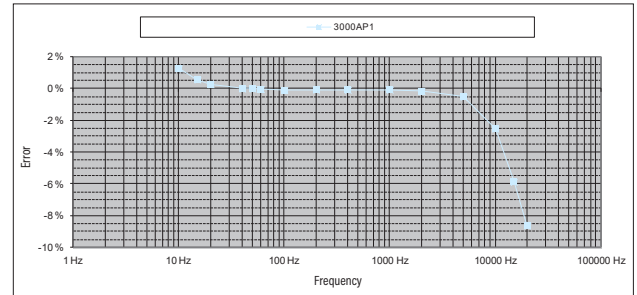

Typical phase shift according to frequency for a current of 20 A

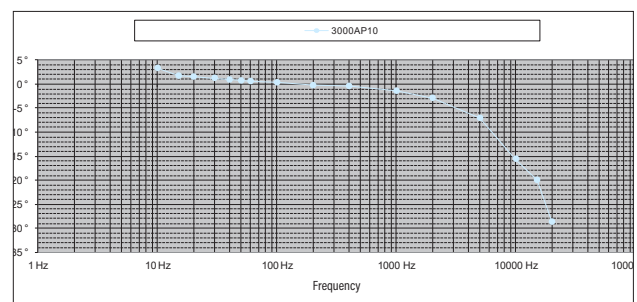

FLEXIBLE PROBES FOR AC CURRENT

Model MA130 30-300-3,000/3 Three-phase

Current	30 A AC	300 A AC	3,000 A AC
Output	100 mV/A	10 mV/A	1 mV/A

Description

The model MA130 MiniFlex sensor is a flexible three-phase sensor three comprising an active part (Rogowski coil) linked to a casing containing electronics.

Unlike a current clamp with magnetic circuits, the MiniFlex models are flexible and are not subject to magnetic saturation constraints, so they offer excellent linearity, low phase shift and a large dynamic range for measurement (up to several kA) while remaining easy to use.

The sensors' flexibility makes it simple to clamp and measure any conductor, whatever its type (cable, busbar, strand, etc. and accessibility). The design of the click-together opening and closing system means it can be handled with protective gloves.

The MiniFlex MA130 can be connected to the AC voltage inputs (mV AC, V AC) of any power analyser, logger or measuring instrument equipped with BNC plugs.

The MiniFlex MA130 model can be powered by batteries or by a standard external power supply. If the power supply fails, the instrument's batteries take over.

To maximize the battery life, the MiniFlex MA130 model has an automatic standby system which can be deactivated at start-up to perform long-term measurement campaigns.

The MiniFlex MA130 model has 3 green, yellow and red LEDs indicating, respectively, the power supply status, the status of the automatic standby function and any overruns of the measurement capacity.



Specifications for current measurement ⁽¹⁾

Calibre (I_N)	30 A	300 A	3,000 A
Measurement range in use	0.5 .. 30 A AC	0.5 .. 300 A AC	0.5 .. 3,000 A AC
Specified measurement range	5 .. 30 A AC	5 .. 300 A AC	50 .. 3,000 A AC
Output/input ratio	100 mV / A	10 mV / A	1 mV / A
Bandwidth at -3 dB	10 Hz .. 20 kHz	10 Hz .. 20 kHz	10 Hz .. 20 kHz
Frequency limitation	Null	Null	See curve
Intrinsic uncertainty	$\leq 1\% + 4\text{ mV}$	$\leq 1.5\% + 0.4\text{ mV}$ ($I < 10\% I_N$) $\leq 1\% + 0.4\text{ mV}$ ($I \geq 10\% I_N$)	$\leq 1.5\% + 0.04\text{ mV}$ ($I < 10\% I_N$) $\leq 1\% + 0.04\text{ mV}$ ($I \geq 10\% I_N$)
Phase shift at 50 Hz	$\leq 1^\circ$ (0.5° typical)	$\leq 1^\circ$ (0.5° typical)	$\leq 1^\circ$ (0.5° typical)

Electrical specifications ⁽¹⁾

- Operating voltage:**
600 V_{RMS} (Cat. IV)
1,000 V_{RMS} (Cat. III)
- Battery:**
Two 1.5 V batteries (NEDA 15A, IEC LR6, AA)
+5 V DC via a μ USB Type B connector
- Battery life ⁽²⁾:**
500 hours typical
3,000 10-minute approx. measurements
- Consumption:**
10 μ A (OFF position)
90 μ A (sleep mode)
- Battery level indication:**
Flashing green LED (batteries voltage > 2 V)
- Influence of battery voltage:**
 $\leq 0.1\%$ (0.02 % typical) from 3.1 V to 2 V
- Influence of temperature:**
 $\leq 0.5\%$ (0.15 % typical) of output signal per 10 °K
- Influence of relative humidity:**
 $\leq 0.5\%$ (0.2 % typical) of output signal
- Influence of conductor position in the sensor ⁽³⁾:**
 $\leq 2.5\%$ (1 % typical)
- Influence of sensor deformation ⁽⁴⁾:**
 $\leq 1\%$ (0.2 % typical)
- Influence of adjacent conductor ⁽⁵⁾:**
 $\leq I_{ADJ} \times 1\%$ (2 % near click-lock system)
(0.2 % typical)
- Input impedance of the measuring instrument:**
 $\geq 1\text{ M}\Omega$
- Common mode rejection ⁽⁶⁾:**
 $\leq 80\text{ dB}$ (100 dB typical)
- Influence of the measurement instrument's impedance Z:**
 $\leq 0.1\%$ at 10 k Ω

FLEXIBLE PROBES FOR AC CURRENT

Model MA130 30-300-3,000/3 Three-phase

Mechanical specifications

- **Clamping capacity:**
Model length 250 mm: Ø max 70 mm
- **Bending radius:**
≥ 20 mm
- **Operating temperature:**
-10°C to +55°C
- **Storage temperature:**
-40°C to +70°C
- **Max. temperature of clamped conductor (measured):**
90 °C for 10 minutes max.
- **Relative humidity for operation:**
0 to 85 % RH with a linear decrease above 35 °C
- **Operating altitude:**
0 to 2,000 m
- **Casing protection rating (leakproofing):**
Intermediate casing: IP54
Flexible sensor: IP 67
According to IEC 60529 Ed. 2.2-2013

- **Drop test:**
1 m (CEI 68-2-32)
- **Self-extinguishing capability:**
Casing: UL94-V0
Sensor: UL94 V0
- **Dimensions:**
Intermediate casing: 120 x 55 x 39 (overall)
Length of intermediate cable linking the sensor/ processing unit: 3 m
Length of output cable: 0.5 m
Ø of sensor: 6 mm
Connection cable Ø: 4 mm
- **Weight:**
500 g
- **Colours:**
Sensor: red
Sensor closing system: dark grey
Intermediate casing: Dark grey
- **Output:**
3 coaxial cables with reinforced or double isolation terminated by 1 black isolated male BNC plug

Safety specifications

- **Electrical safety:**
Class II equipment with double or reinforced insulation between the primary and the secondary (winding connected to the connection cable) as per EN 61010-1 and 61010-2-032 Ed. 03-2012:
 - Sensor:
Type B
600 V Cat. IV / 1,000 V Cat. III, pollution degree 2
 - Intermediate casing:
600 V Cat. III between the BNC output and the external enclosure of the casing
- **Electromagnetic compatibility (EMC):** :
Complies with the industrial environments according to EN 61326-1 Ed. 02-2012:
 - Immunity to radiated fields: at 3 V/m, error ≤ 5% of measuring range (criterion A)

3,000 A calibre

Frequency limitation according to amplitude

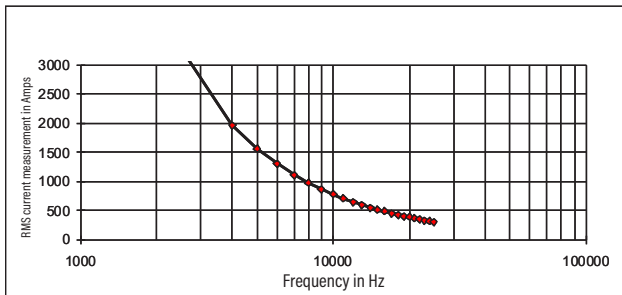

- (1) Conditions of reference: 23 °C ± 5 °K, 20 % to 75 % RH
Battery voltage 3.2 V ± 0.1 VDC
Frequency and form of signal measured: 30 to 440 Hz sinusoidal
Continuous magnetic field < 40 A/m
Absence of external H_{ac} magnetic field
Absence of external electrical field
Measured conductor centred in the circular sensor (coil) after operation for 1 minute
Measurement instrument input impedance ≥ 1 MΩ
- (2) With 3,000 mA/h batteries, for a supplied voltage between 3.2 V and 1.8 V (1.6 V to 0.9 V per battery), giving an average voltage of 2.8 V
- (3) Whatever the conductor's position within the loop, as long as the sensor is not distorted (circular sensor)
- (4) Oblong shape
- (5) Adjacent conductor carrying an AC current I_{adj} , in contact with the sensor
- (6) For a 600 V voltage applied between the enclosure and the secondary
- (7) Delivered with a set of 3 female BNC/ Ø 4 mm isolated male banana adapters with 19 mm spacing and a set of identifiers (12 colours)

To order	Reference
MiniFlex MA130 30-300-3,000 A / 3 V, sensor length 250 mm, output via 3 coaxial cables terminated by 1 isolated security BNC lead ⁽⁷⁾	P01120663

FLEXIBLE PROBES FOR AC CURRENT

Model MA130 30-300-3,000/3 Three-phase

Frequency response

30 A calibre

Typical error on measurement according to frequency for a current of 20 A

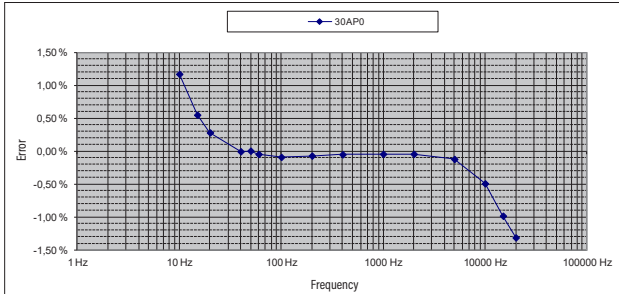

Typical phase shift according to frequency for a current of 20 A

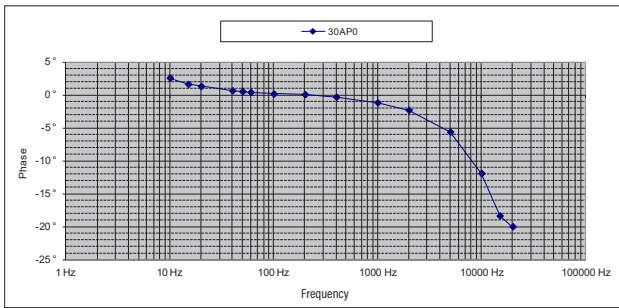

300 A calibre

Typical error on measurement according to frequency for a current of 20 A

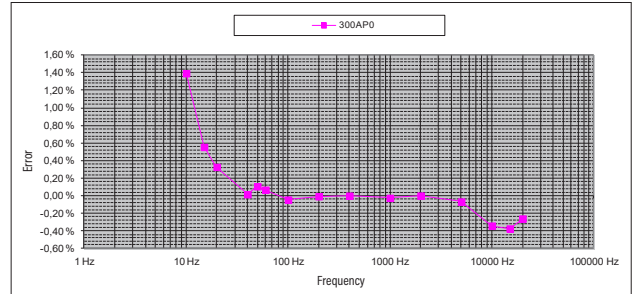

Typical phase shift according to frequency for a current of 20 A

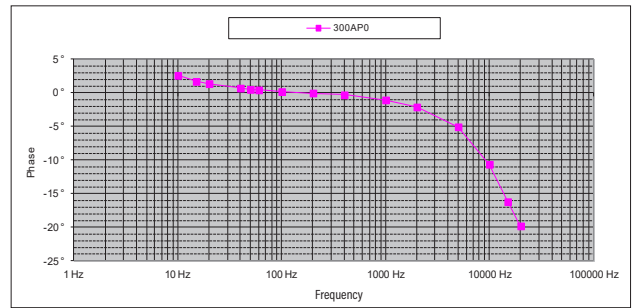

3,000 A calibre

Typical error on measurement according to frequency for a current of 20 A

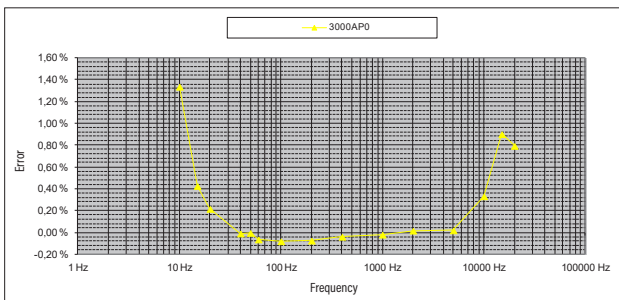

Typical phase shift according to frequency for a current of 20 A

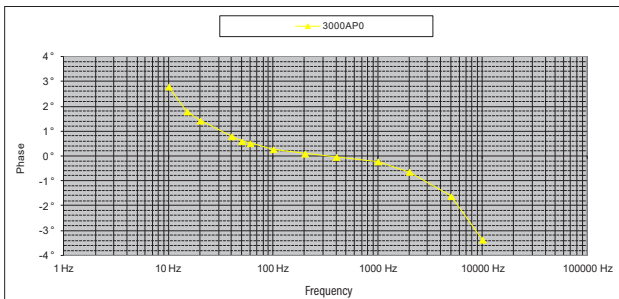

FLEXIBLE OSCILLOSCOPE PROBES FOR AC CURRENT

Model MA200 30-300/3 (insulated AC current probe)

Current	45 A peak	450 A peak
Output	100 mV / A	10 mV / A

Description

The model MA200 MiniFlex sensor is a flexible sensor comprising an active part (Rogowski coil) linked to a casing containing electronics.

Unlike a current clamp with magnetic circuits, the MiniFlex models are flexible and are not subject to magnetic saturation constraints, so they offer excellent linearity, low phase shift and a large dynamic range for measurement (up to several kA) while remaining easy to use.

The oscilloscope probes in the MA200 series are specially designed for viewing alternating currents in order to assess the transition and propagation times on electro-technical equipment.

The sensors' flexibility makes it simple to clamp and measure any conductor, whatever its type (cable, busbar, strand, etc. and accessibility).

The design of the click-together opening and closing system means it can be handled with protective gloves.

The casing can be connected to any oscilloscope equipped with an AC voltage input.

Specifications for current measurement ⁽¹⁾

Calibre	30 A	300 A
Measurement range in use	0.5 .. 30 A AC (45 A peak)	0.5 .. 300 A AC (450 A peak)
Specified measurement range ⁽²⁾	5 .. 30 A AC (45 A peak)	5 .. 300 A AC (450 A peak)
Output/input ratio	100 mV/A	10 mV/A
Accuracy in % of output signal	≤ 1% + 0.3 A	
Phase shift at 1 kHz	≤ 1.5°	
Residual current (noise) at I = 0	≤ 0.5 A _{RMS}	
Output impedance	1 kΩ	

Frequency measurement specifications ⁽¹⁾

Calibre	30 A	300 A
Bandwidth at -3 dB	2 Hz .. 1 MHz	2 Hz .. 1 MHz
Rise time ⁽³⁾ (10 to 90 %)	0.3 μs (typical)	0.24 μs (typical)
Fall time ⁽⁴⁾ (10 to 90 %)	0.3 μs (typical)	0.24 μs (typical)
Propagation time ⁽⁵⁾ (to 10 %)	0.4 μs (typical)	0.3 μs (typical)
Insertion impedance at 10 kHz	< 0.05 mΩ	



FLEXIBLE OSCILLOSCOPE PROBES FOR AC CURRENT

Model MA200 30-300/3 (insulated AC current probe)

Electrical specifications ⁽¹⁾

- **Operating voltage:**
600 V_{RMS} (Cat. IV)
1,000 V_{RMS} (Cat. III)
- **Battery:**
9 V alkaline battery (NEDA 1604A, IEC 6LR61)
- **Battery life:**
100 hours typical
- **Typical consumption:**
3.6 mA typical
- **Battery level indication:**
Green LED when > 7.0 V approx.
- **Influence of battery voltage:**
≤ 0.1 % from 9 V to 7 V
- **Influence of temperature:**
≤ 0.2 % / 10 K
- **Influence of humidity:**
≤ 0.5 % from 10 % to 90 % RH without condensation
- **Influence of conductor position in the sensor ⁽⁸⁾:**
≤ 2.5 %
- **Influence of sensor deformation ⁽⁶⁾:**
≤ 1 %
- **Influence of an adjacent conductor with circulating AC current ⁽⁷⁾:**
≤ 1.5 % or 36.5 dB
- **Common mode rejection:**
Between enclosure and secondary: ≤ 75 dB
Between sensor and secondary: ≤ 80 dB
- **Influence of the measurement instrument's impedance Z:**
0.1 % / Z (in MΩ)

Mechanical specifications

- **Clamping capacity:**
Model length 170 mm: Ø max 45 mm
Model length 250 mm: Ø max 70 mm
- **Operating temperature:**
-10°C to +55°C
- **Storage temperature:**
-40°C to +70°C
- **Max. temperature of clamped conductor (measured):**
≤ 90 °C
- **Relative humidity for operation:**
0 to 85 % RH with a linear decrease above 35 °C
- **Operating altitude:**
0 to 2,000 m
- **Storage altitude:**
≤ 12,000 m
- **Casing protection rating (leakproofing):**
Casing: IP50
Sensor: IP50
According to EN 60529/A1 Ed. 06/2000
- **Shock resistance:**
IK04 according to NF EN 50102 Ed. 1995
- **Self-extinguishing capability:**
Casing: UL94-V2
Sensor: UL94 V0
- **Dimensions:**
Casing: 140 x 64 x 28 mm
Connector lead: 2 m
Ø of sensor: 5.5 mm approx.
Connection cable Ø: 3 mm approx.

- **Colours:**
Sensor: red
Sensor closing system: dark grey
Sensor locking tab: yellow
Casing: Dark grey
- **Output:**
According to model: Coaxial cable 40 cm long, terminated by an insulated BNC plug

Safety specifications

- **Electrical safety:**
Class II equipment with double or reinforced insulation between the primary and the secondary (winding connected to the connection cable) as per EN 61010-1 and 61010-2-032 Ed.
- 1,000 V Cat. III, pollution degree 2
- 600 V Cat. IV, pollution degree 2
- Type-B sensor
- 600 V Cat. III between the BNC output and the external enclosure of the casing
- **Electromagnetic compatibility (EMC):** :
Complies with the IEC 61326 (Ed. 1997) + A1 (Ed. 1998)
- Adequate immunity to disturbances for industrial environments
- Adequate immunity to disturbances for residential environments

(1) Conditions of reference: 23 °C ± 5 °K, 20 % to 75 % RH

Battery voltage: 9 V ± 0.5 V

Continuous external DC magnetic field (earth field) < 40 A/m

Absence of external AC magnetic field

External electrical field < 1 V/m

Position of conductor measured: centred in the measurement coil

Shape of measurement coil: quasi-circular

Measurement instrument input impedance (oscilloscope) ≥ 1 MΩ

Frequency and form of signal measured: 40 to 400 Hz sinusoidal.

(2) Measurement range for the specifications indicated in this document.

(3) Rise Time (rt)

(4) Fall Time (ft)

(5) Delay Time (dt)

(6) Oblong shape

(7) Adjacent conductor 1 cm from sensor; ≤ 3 % or 30.5 dB near click-lock system

(8) ≤ 6 % near click-lock system

(9) Typical curve obtained by mathematical modelling

FLEXIBLE OSCILLOSCOPE PROBES FOR AC CURRENT

Model MA200 30-300/3 (insulated AC current probe)

170 mm loop - 30 A calibre

Frequency and phase responses ⁽⁹⁾

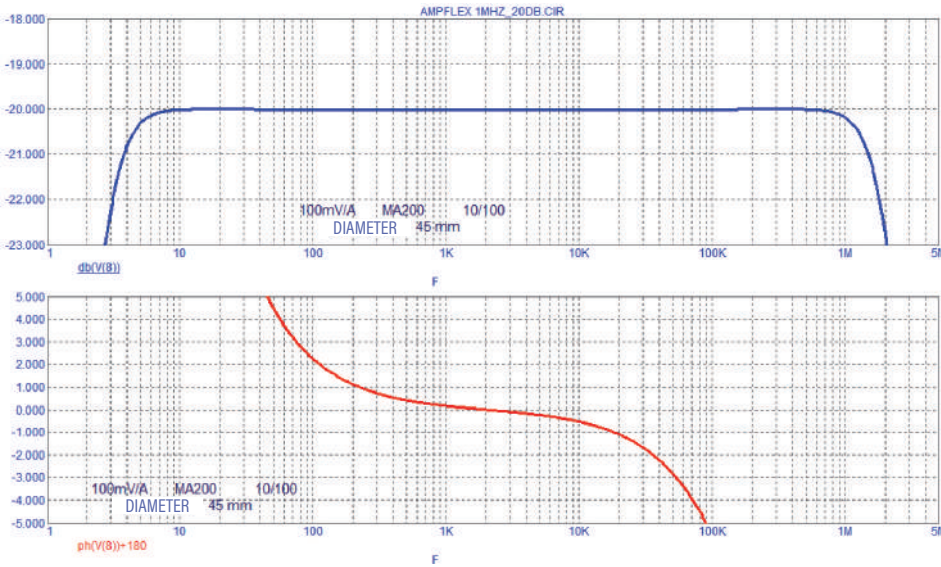

Pulse response

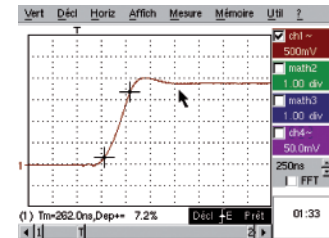

170 mm loop - 300 A calibre

Frequency and phase responses ⁽⁹⁾

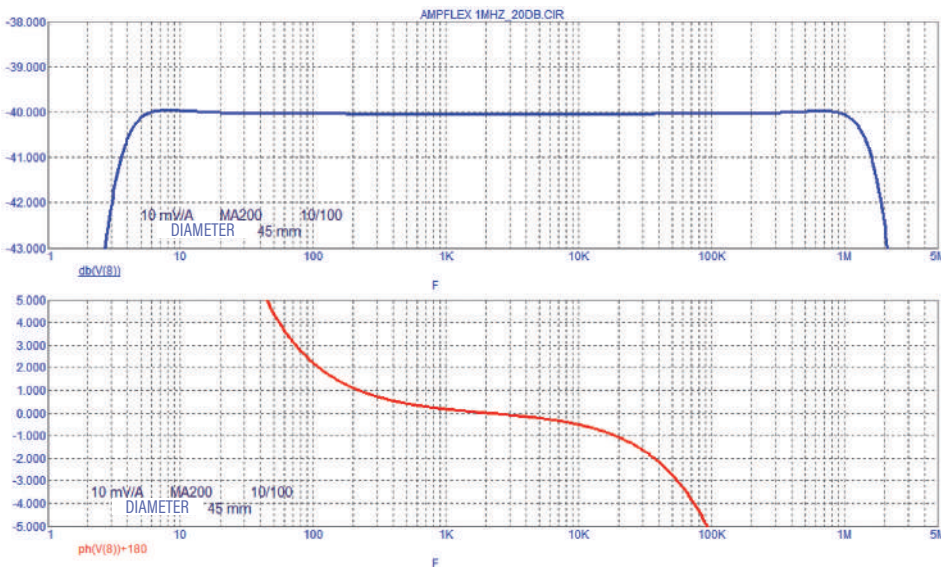

Pulse response

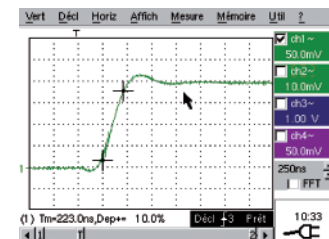

FLEXIBLE OSCILLOSCOPE PROBES FOR AC CURRENT

Model MA200 30-300/3 (insulated AC current probe)

250 mm loop - 30 A calibre

Frequency and phase responses ⁽⁹⁾

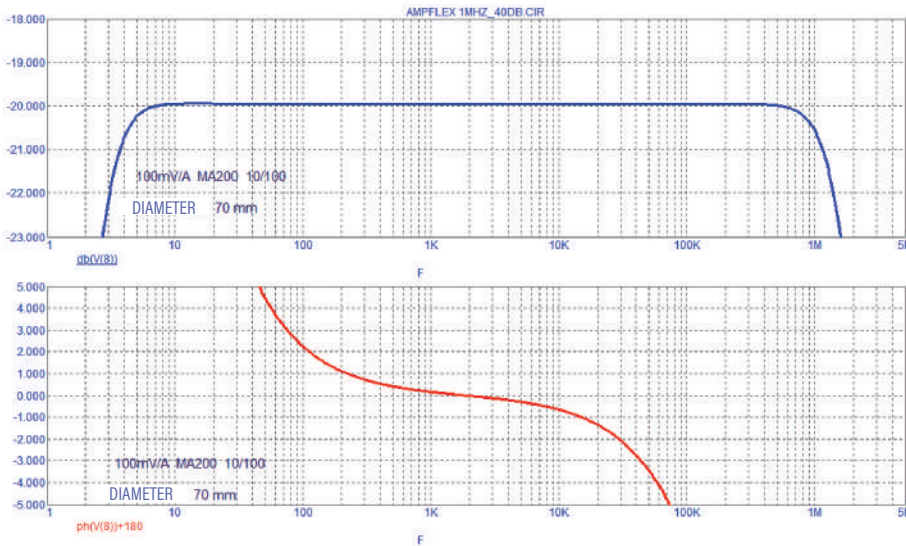

Pulse response

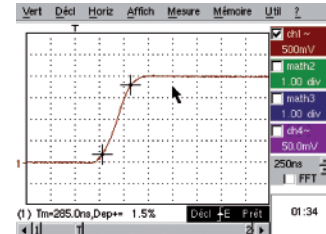

250 mm loop - 300 A calibre

Frequency and phase responses ⁽⁹⁾

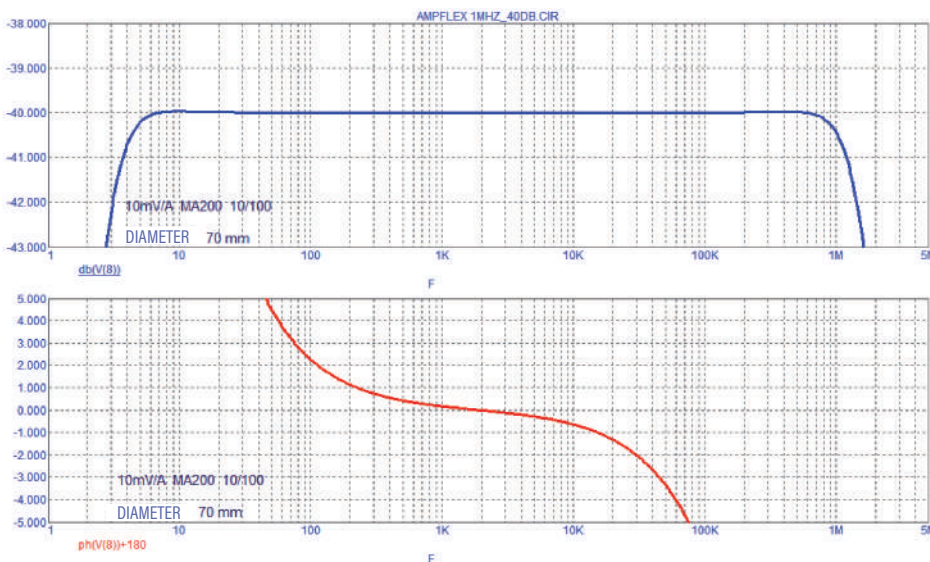

Pulse response

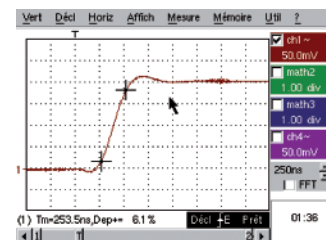

To order		Reference
MiniFlex MA200	30-300 A / 3 V, length 170 mm with operating manual and Battery	P01120570
MiniFlex MA200	30-300 A / 3 V, length 250 mm with operating manual and Battery	P01120571

FLEXIBLE OSCILLOSCOPE PROBES FOR AC CURRENT

Model MA200 3,000/3 (insulated AC current probe)

Current	4500 A peak
Output	1 mV / A

Description

The model MA200 MiniFlex sensor is a flexible sensor comprising an active part (Rogowski coil) linked to a casing containing electronics.

Unlike a current clamp with magnetic circuits, the MiniFlex models are flexible and are not subject to magnetic saturation constraints, so they offer excellent linearity, low phase shift and a large dynamic range for measurement (up to several kA) while remaining easy to use.

The oscilloscope probes in the MA200 series are specially designed for viewing alternating currents in order to assess the transition and propagation times on electro-technical equipment.

The sensors' flexibility makes it simple to clamp and measure any conductor, whatever its type (cable, busbar, strand, etc. and accessibility).

The design of the click-together opening and closing system means it can be handled with protective gloves.

The casing can be connected to any oscilloscope equipped with an AC voltage input.



Specifications for current measurement ⁽¹⁾

Calibre	3,000 A
Measurement range in use	0.5 .. 3,000 A AC (4,500 A peak)
Specified measurement range ⁽²⁾	5 .. 3,000 A AC (4,500 A peak)
Output/input ratio	1 mV/A
Accuracy in % of output signal	≤ 1% + 0.3 A
Phase shift at 1 kHz	≤ 1.5°
Residual current (noise) at I = 0	≤ 0.5 A _{RMS}
Output impedance	1 kΩ

Frequency measurement specifications ⁽¹⁾

Calibre	3,000 A
Bandwidth at -3 dB ⁽⁶⁾	2 Hz .. 1 MHz
Rise time ⁽³⁾ (10 to 90 %)	0.3 μs (typical)
Fall time ⁽⁴⁾ (10 to 90 %)	0.3 μs (typical)
Propagation time ⁽⁵⁾ (to 10 %)	0.4 μs (typical)
Insertion impedance at 10 kHz	< 0.05 mΩ

Electrical specifications ⁽¹⁾

- Operating voltage:**
600 V_{RMS} (Cat. IV)
1,000 V_{RMS} (Cat. III)
- Battery:**
9 V alkaline battery (NEDA 1604A, IEC 6LR61)
- Battery life:**
100 hours typical
- Typical consumption:**
3.6 mA typical
- Battery level indication:**
Green LED when > 7.0 V approx.
- Influence of battery voltage:**
≤ 0.1 % from 9 V to 7 V
- Influence of temperature:**
≤ 0.6 % / 10 K
- Influence of humidity:**
≤ 0.5 % from 10 % to 90 % RH without condensation
- Influence of conductor position in the sensor ⁽⁹⁾:**
≤ 2.5 %
- Influence of sensor deformation ⁽⁷⁾:**
≤ 1 %
- Influence of an adjacent conductor with circulating AC current ⁽⁸⁾:**
≤ 1.5 % or 36.5 dB
- Common mode rejection:**
between enclosure and secondary: ≤ 75 dB
between sensor and secondary: ≤ 80 dB
- Influence of the measurement instrument's impedance Z:**
0.1% / Z (in mΩ)

FLEXIBLE OSCILLOSCOPE PROBES FOR AC CURRENT

Model MA200 3,000/3 (insulated AC current probe)

Mechanical specifications

- **Clamping capacity:**
Model length 350 mm: Ø max 100 mm
- **Operating temperature:**
-10°C to +55°C
- **Storage temperature:**
-40°C to +70°C
- **Max. temperature of clamped conductor (measured):**
≤ 90 °C
- **Relative humidity for operation:**
0 to 85 % RH with a linear decrease above 35 °C
- **Operating altitude:**
0 to 2,000 m
- **Storage altitude:**
≤ 12,000 m
- **Casing protection rating (leakproofing):**
Casing: IP50
Sensor: IP50
According to EN 60529/A1 Ed. 06/2000

- **Shock resistance:**
IK04 according to NF EN 50102 Ed. 1995
- **Self-extinguishing capability:**
Casing: UL94 V2
Sensor: UL94 V0
- **Dimensions:**
Casing: 140 x 64 x 28 mm
Connector lead: 2 m
Ø of sensor: 5.5 mm approx.
Connection cable Ø: 3 mm approx.
- **Colours:**
Sensor: red
Sensor closing system: dark grey
Sensor locking tab: yellow
Casing: Dark grey
- **Output:**
Coaxial cable 40 cm long, terminated by an insulated BNC plug

Safety specifications

- **Electrical safety:**
Class II equipment with double or reinforced insulation between the primary and the secondary (winding connected to the connection cable) as per EN 61010-1 and 61010-2-032 Ed.
- 1,000 V Cat. III, pollution degree 2
- 600 V Cat. IV, pollution degree 2
- Type-B sensor
- 600 V Cat. III between the BNC output and the external enclosure of the casing
- **Electromagnetic compatibility (EMC):** :
Complies with the IEC 61326 (Ed. 1997) + A1 (Ed. 1998)
- Adequate immunity to disturbances for industrial environments
- Adequate immunity to disturbances for residential environments

(1) Conditions of reference: 23 °C ± 5 °K, 20 % to 75 % RH Battery voltage: 9 V ± 0.5 V, continuous external DC magnetic field (earth field) < 40 A/m, absence of external AC magnetic field, external electrical field < 1 V/m, position of conductor measured: centred in the measurement coil, shape of measurement coil: quasi-circular, measurement instrument input impedance (oscilloscope) ≥ 1 MΩ, frequency and form of signal measured: 40 to 400 Hz sinusoidal.

(2) Measurement range for the specifications indicated in this document.

(3) Rise Time (rt)

(4) Fall Time (ft)

(5) Delay Time (dt)

(6) Frequency limitation according to amplitude

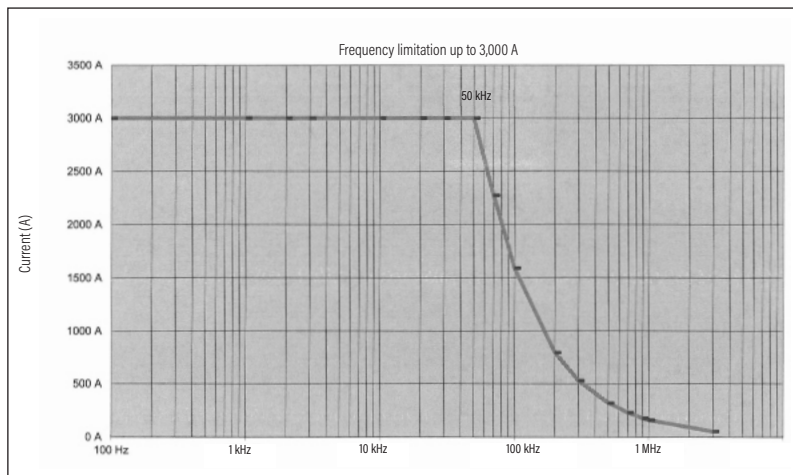

(7) Oblong shape

(8) Adjacent conductor 1 cm from sensor; ≤ 3 % or 30.5 dB near click-lock system

(9) ≤ 6 % near click-lock system

(10) Typical curve obtained by mathematical modelling

To order	Reference
MiniFlex MA200 3,000 A / 3 V, length 350 mm with operating manual and Battery	P01120572

FLEXIBLE OSCILLOSCOPE PROBES FOR AC CURRENT

Model MA200 3,000/3 (insulated AC current probe)

3,000 A calibre

Frequency and phase responses ⁽¹⁰⁾

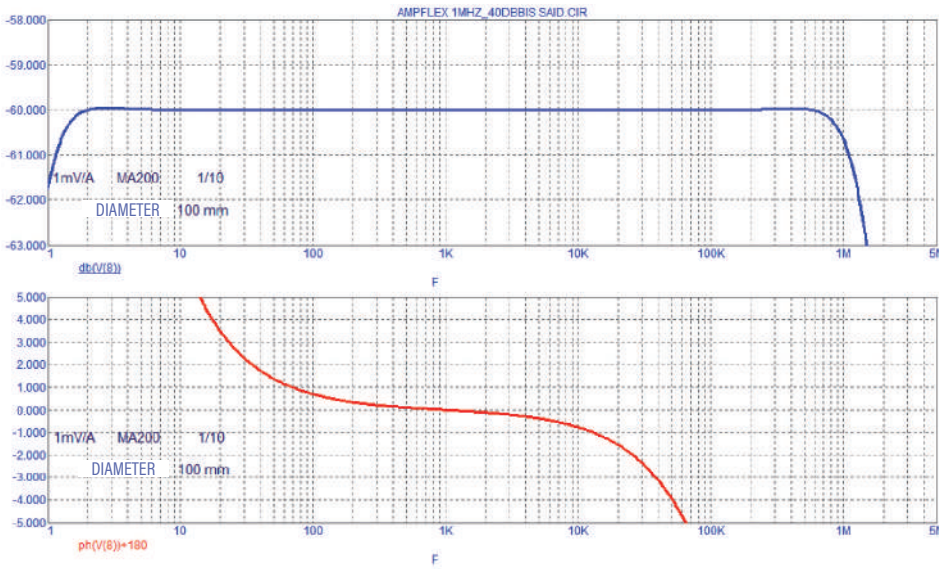

Pulse response

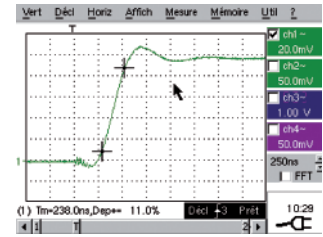

NOTES

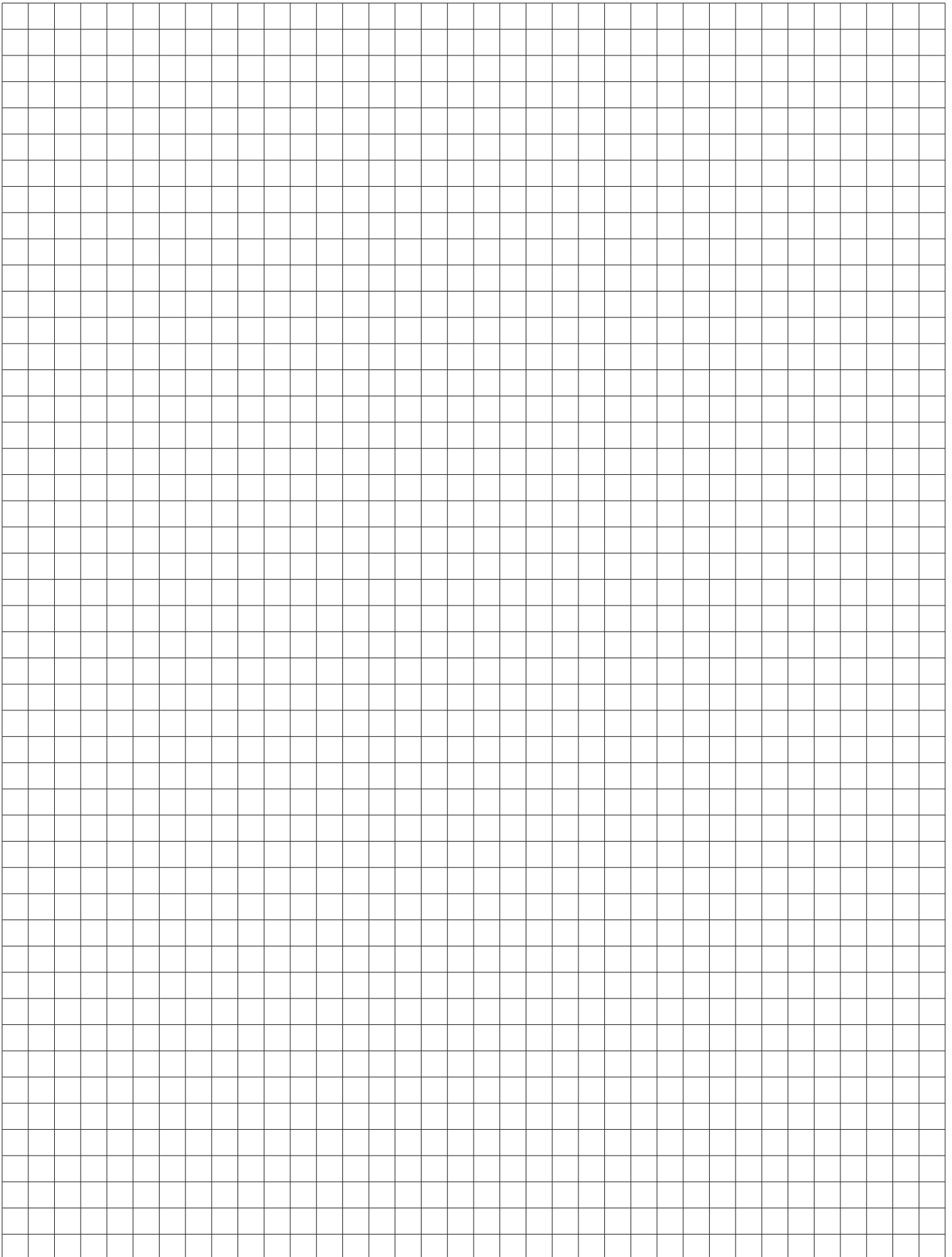

FLEXIBLE PROBES FOR AC CURRENT



Model AmpFlex®

These flexible current probes are as at home measuring low AC currents of a few tens mA as they are measuring high currents of several tens of kA.

Their main point of interest is their flexibility and the ease with which electrical conductors of all shapes and sizes (cables, busbars) and degrees of accessibility can be gripped.

They have a number of other advantages; they are lightweight (no magnetic circuit), they do not suffer from the saturation effect and their high level of accuracy combined with minimal phase shift make them perfect for power measurement applications.

- **AmpFlex® A110 series:**

The sensors in the A110 series have a flexible core connected by a shielded cable to a small unit containing processing electronics. This IP54 unit offers 4 measurement calibres and can be connected directly to any multimeter, wattmeter or logger. The length of the sensors in this series (up to 120 cm as standard) enables you to clamp cables with a large cross-section or several conductors simultaneously. The A110 can be used for measurements up to 30 kA AC.

The AmpFlex® A110 offers IP67 ingress protection and can be connected to the AC voltage input (mV AC, V AC) of any multimeter or measuring instrument equipped with Ø 4 mm female banana plugs.

- **AmpFlex® A130:**

The A130 model is a version of the A110 series adapted for measurements on three-phase installations. It is equipped with BNC connections. The processing unit offers 3 measurement calibres. The A130 sensor can be connected to the AC voltage inputs (mV AC, V AC) of any power analyser, logger or measuring instrument equipped with BNC plugs.

FLEXIBLE PROBES FOR AC CURRENT

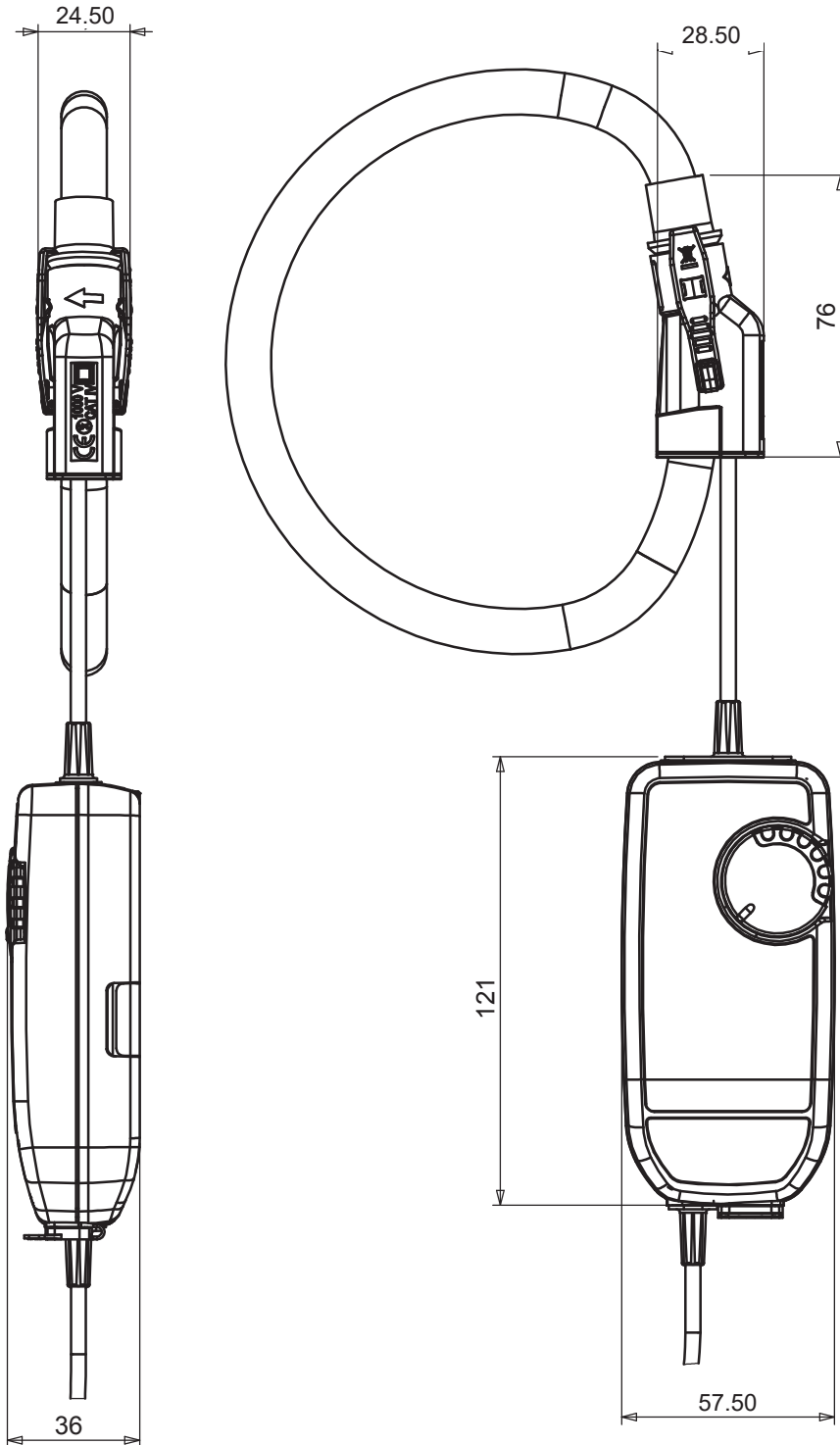

FLEXIBLE PROBES FOR AC CURRENT

Model A110 3-30-300-3,000/3

Current	3 A AC	30 A AC	300 A AC	3,000 A AC
Output	1 mV/mA	100 mV/A	10 mV/A	1 mV/A

Description

The AmpFlex® A110 is a flexible sensor which comprises an active part (Rogowski coil) and a casing containing an electronic processing unit.

Unlike current clamps using magnetic circuits, the AmpFlex® models are flexible sensors without magnetic saturation constraints. As a result, they offer excellent linearity, low phase shift, a large dynamic range for measurement (up to several kA) while remaining easy to use.

The sensors' flexibility makes it simple to clamp and measure any conductor, whatever its type (cable, busbar, strand, etc. and accessibility).

The design of the click-together opening and closing system means it can be handled with protective gloves.

The AmpFlex® A110 can be connected to the AC voltage input (mV AC, V AC) of any multimeter or measuring instrument equipped with Ø 4 mm female banana plugs.

The AmpFlex® A110 can be powered by batteries or a standard external power supply. If the power supply fails, the instrument's batteries take over.

To maximize the battery life, the MiniFlex A110 has an automatic standby system which can be deactivated at start-up to perform long-term measurement campaigns.

The MiniFlex A110 has 3 green, yellow and red LEDs indicating, respectively, the power supply status, the status of the automatic standby function and any overruns of the measurement capacity.



Specifications for current measurement ⁽¹⁾

Calibre (I _N)	3 A	30 A	300 A	3,000 A
Measurement range in use	0.08 .. 3 A AC	0.5 .. 30 AC	0.5 .. 300 AC	0.5 .. 3,000 AC
Specified measurement range	0.5 .. 3 AC	2 .. 30 AC	5 .. 300 AC	50 .. 3,000 AC
Output/input ratio	1 V / A (1 mV / mA)	100 mV / A	10 mV / A	1 mV / A
Bandwidth at -3 dB	10 Hz .. 10 kHz	10 Hz .. 20 kHz	10 Hz .. 20 kHz	10 Hz .. 20 kHz
Frequency limitation	Null	Null	Null	See curve
Intrinsic uncertainty	≤ 1% + 40 mV	≤ 1% + 4 mV	≤ 1.5% + 0.4 mV (I < 10% I _N) ≤ 1% + 0.4 mV (I ≥ 10% I _N)	≤ 1.5% + 0.04 mV (I < 10% I _N) ≤ 1% + 0.04 mV (I ≥ 10% I _N)
Phase shift at 50 Hz	≤ 1° (0.5° typical)	≤ 1° (0.5° typical)	≤ 1° (0.5° typical)	≤ 1° (0.5° typical)

Electrical specifications ⁽¹⁾

- **Operating voltage:**
1,000 V_{RMS} (Cat. IV)
- **Battery:**
Two 1.5 V batteries (NEDA 15A, IEC LR6, AA)
+5 V DC via a µUSB Type B connector
- **Battery life ⁽²⁾:**
300 hours typical
1,800 10-minute approx. measurements
- **Consumption:**
10 µA (OFF position)
90 µA (sleep mode)
- **Battery level indication:**
Flashing green LED (batteries voltage > 2 V)
- **Influence of battery voltage:**
≤ 0.1% (0.02% typical) from 3.1 V to 2 V
- **Influence of temperature:**
≤ 0.5% (0.15% typical) of output signal per 10 °K
- **Influence of relative humidity:**
≤ 0.5% (0.2% typical) of output signal
- **Influence of conductor position in the sensor ⁽³⁾:**
≤ 2.5% (1% typical)
- **Influence of sensor deformation ⁽⁴⁾:**
≤ 1% (0.2% typical)
- **Influence of adjacent conductor ⁽⁵⁾:**
≤ I_{ADJ} x 1% (2% near click-lock system)
(0.2% typical)
- **Input impedance of the measuring instrument:**
≥ 1 MΩ
- **Common mode rejection ⁽⁶⁾:**
≤ 80 dB (100 dB typical)
- **Influence of the measurement instrument's impedance Z:**
≤ 0.1% at 10 kΩ

FLEXIBLE PROBES FOR AC CURRENT

Model A110 3-30-300-3,000/3

Mechanical specifications

- **Clamping capacity:**
Model length 45 cm: Ø max 12 cm
Model length 80 cm: Ø max 23.5 cm
- **Bending radius:**
≥ 40 mm
- **Operating temperature:**
-10°C to +55°C
- **Storage temperature:**
-40°C to +70°C
- **Max. temperature of clamped conductor (measured):**
90 °C for 10 minutes max.
- **Relative humidity for operation:**
0 to 85 % RH with a linear decrease above 35 °C
- **Operating altitude:**
0 to 2,000 m
- **Casing protection rating (leakproofing):**
Intermediate casing: IP54
Flexible sensor: IP 67
According to IEC 60529 Ed. 2.2-2013

- **Drop test:**
1 m
- **Self-extinguishing capability:**
Casing: UL94-V0
Sensor: UL94 V0
- **Dimensions:**
Intermediate casing: 120 x 55 x 39 (overall)
Length of intermediate cable linking the sensor/ processing unit: 2 m
Length of output cable: 0.5 m
Ø of sensor: 12 mm
Connection cable Ø: 4 mm
- **Weight:**
Model length 45 mm: 450 g
Sensor: 30 g / 10 cm
- **Colours:**
Sensor: red
Sensor closing system: dark grey
Intermediate casing: Dark grey
- **Output:**
Two-wire cable with reinforced or double insulation terminated by 2 red and black isolated male banana plugs Ø 4 mm

Safety specifications

- **Electrical safety:**
Class II equipment with double or reinforced insulation between the primary and the secondary (winding connected to the connection cable) as per EN 61010-1 and 61010-2-032 Ed. 03-2012:
- Sensor:
Type B
1,000 V Cat. IV pollution degree 2
Intermediate casing:
600 V Cat. III between the terminals and the external enclosure of the casing
- **Electromagnetic compatibility (EMC):** :
Complies with the industrial environments according to EN 61326-1 Ed. 02-2012:
- Immunity to radiated fields: at 3 V/m, error ≤ 5% of measuring range (criterion A)

- (1) Conditions of reference: 23 °C ± 5 °K, 20 % to 75 % RH
Battery voltage 3.2 V ± 0.1 VDC
Frequency and form of signal measured: 30 to 440 Hz sinusoidal
Continuous magnetic field < 40 A/m
Absence of external AC magnetic field
Absence of external electrical field
Measured conductor centred in the circular sensor (coil) after operation for 1 minute
Measurement instrument input impedance ≥ 1 MΩ
- (2) With 3,000 mA/h batteries, for a supplied voltage between 3.2 V and 1.8 V (1.6 V to 0.9 V per battery), giving an average voltage of 2.8 V
- (3) Whatever the conductor's position within the loop, as long as the sensor is not distorted (circular sensor)
- (4) Oblong shape
- (5) Adjacent conductor carrying an AC current I_{adj} , in contact with the sensor
- (6) For a 600 V voltage applied between the enclosure and the secondary

3,000 A calibre

Frequency limitation according to amplitude

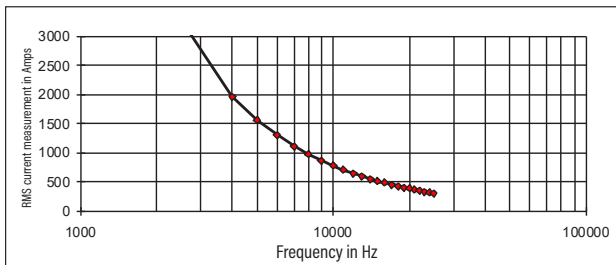

To order	Reference
AmpFlex® A110 3-30-300-3,000 A / 3 V, sensor length 45 cm, Output via cable terminated by 2 x Ø 4 mm isolated male banana plugs	P01120630
AmpFlex® A110 3-30-300-3,000 A / 3 V, sensor length 80 cm, Output via cable terminated by 2 x Ø 4 mm isolated male banana plugs	P01120631

FLEXIBLE PROBES FOR AC CURRENT

Model A110 3-30-300-3,000/3

Frequency response

3 A calibre

Typical error on measurement according to frequency for a current of 2 A

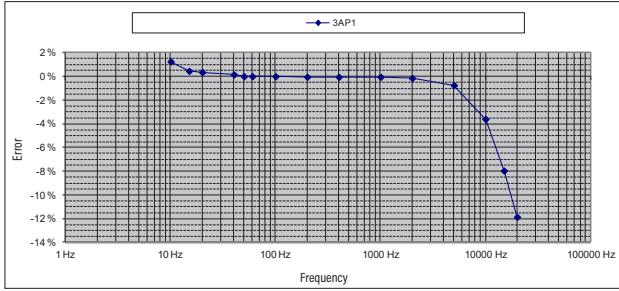

30 A calibre

Typical error on measurement according to frequency for a current of 20 A

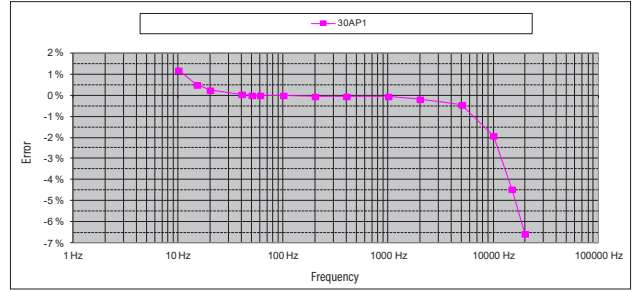

Typical phase shift according to frequency for a current of 2 A

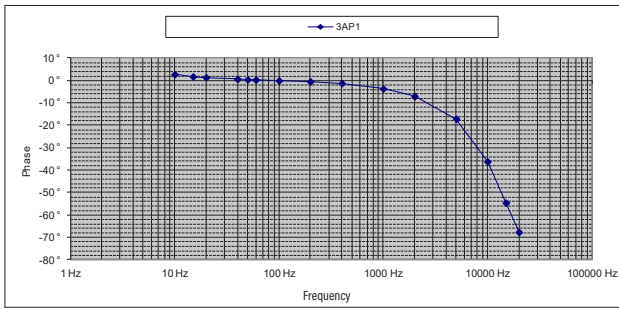

Typical phase shift according to frequency for a current of 20 A

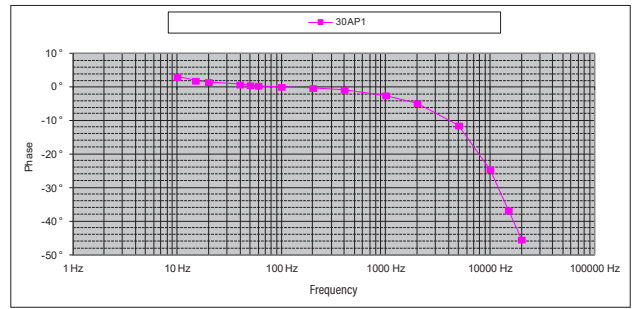

300 A calibre

Typical error on measurement according to frequency for a current of 20 A

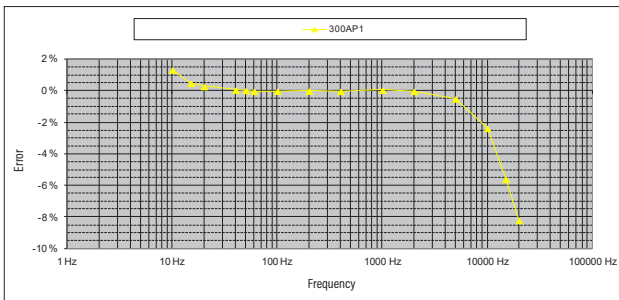

Typical phase shift according to frequency for a current of 20 A

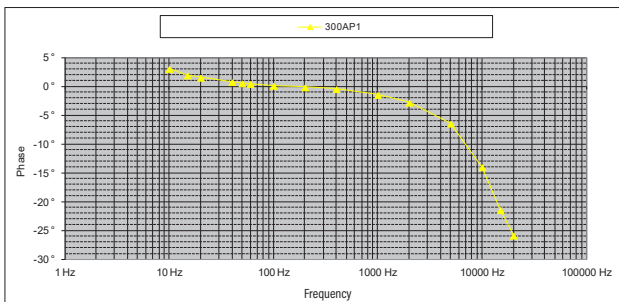

3,000 A calibre

Typical error on measurement according to frequency for a current of 20 A

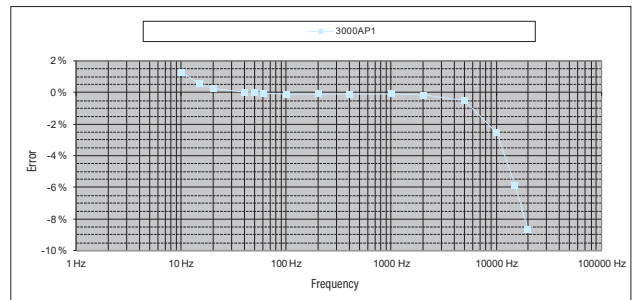

Typical phase shift according to frequency for a current of 20 A

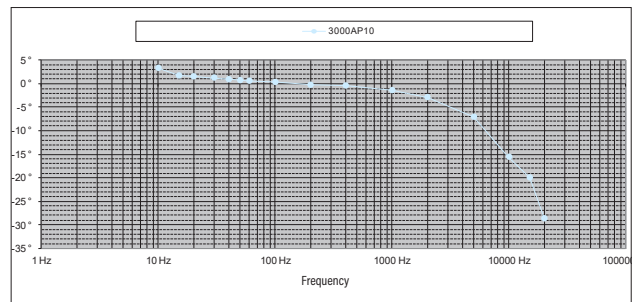

FLEXIBLE PROBES FOR AC CURRENT

Model A110 30-300-3,000-30,000/3

Current	30 A AC	300 A AC	3,000 A AC	30,000 A AC
Output	100 mV/A	10 mV/A	1 mV/A	0.1 mV/A

Description

The AmpFlex® A110 is a flexible sensor which comprises an active part (Rogowski coil) and a casing containing an electronic processing unit.

Unlike current clamps using magnetic circuits, the AmpFlex® models are flexible sensors without magnetic saturation constraints. As a result, they offer excellent linearity, low phase shift, a large dynamic range for measurement (up to several kA) while remaining easy to use.

The sensors' flexibility makes it simple to clamp and measure any conductor, whatever its type (cable, busbar, strand, etc. and accessibility).

The design of the click-together opening and closing system means it can be handled with protective gloves.

The AmpFlex® A110 can be connected to the AC voltage input (mV AC, V AC) of any multimeter or measuring instrument equipped with Ø 4 mm female banana plugs.

The AmpFlex® A110 can be powered by batteries or a standard external power supply. If the power supply fails, the instrument's batteries take over.

To maximize the battery life, the MiniFlex A110 has an automatic standby system which can be deactivated at start-up to perform long-term measurement campaigns. The MiniFlex A110 has 3 green, yellow and red LEDs indicating, respectively, the power supply status, the status of the automatic standby function and any overruns of the measurement capacity.



Specifications for current measurement ⁽¹⁾

Calibre (I _N)	30 A	300 A	3,000 A	30,000 A
Measurement range in use	0.5 .. 30 A AC	0.5 .. 300 A AC	0.5 .. 3,000 A AC	0.5 .. 30,000 A AC
Specified measurement range	0.5 .. 30 A AC	10 .. 300 A AC	10 .. 3,000 A AC	50 .. 30,000 A AC
Output/input ratio	100 mV / A	10 mV / A	1 mV / A	0.1 mV / A
Bandwidth at -3 dB	10 Hz .. 5 kHz	10 Hz .. 20 kHz	10 Hz .. 20 kHz	10 Hz .. 20 kHz
Frequency limitation	Null	Null	See curve	See curve
Intrinsic uncertainty	≤ 1% + 4 mV	≤ 1% + 0.4 mV	≤ 1.5% + 40 mV (I < 10% I _N) ≤ 1% + 40 mV (I ≥ 10% I _N)	≤ 1.5% + 4 mV (I < 10% I _N) ≤ 1% + 4 mV (I ≥ 10% I _N)
Phase shift at 50 Hz	≤ 1° (0.5° typical)	≤ 1° (0.5° typical)	≤ 1° (0.5° typical)	≤ 1° (0.5° typical)

Electrical specifications ⁽¹⁾

- **Operating voltage:**
1,000 V_{RMS} (Cat. IV)
- **Battery:**
Two 1.5 V batteries (NEDA 15A, IEC LR6, AA)
+5 V DC via a µUSB Type B connector
- **Battery life ⁽²⁾:**
300 hours typical
1,800 10-minute approx. measurements
- **Consumption:**
10 µA (OFF position)
90 µA (sleep mode)
- **Battery level indication:**
Flashing green LED (batteries voltage > 2 V)
- **Influence of battery voltage:**
≤ 0.1% (0.02% typical) from 3.1 V to 2 V
- **Influence of temperature:**
≤ 0.5% (0.15% typical) of output signal per 10 °K
- **Influence of relative humidity:**
≤ 0.5% (0.2% typical) of output signal
- **Influence of conductor position in the sensor ⁽³⁾:**
≤ 2.5% (1% typical)
- **Influence of sensor deformation ⁽⁴⁾:**
≤ 1% (0.2% typical)
- **Influence of adjacent conductor ⁽⁵⁾:**
≤ I_{ADJ} x 1% (2% near click-lock system)
(0.2% typical)
- **Input impedance of the measuring instrument:**
≥ 1 MΩ
- **Common mode rejection ⁽⁶⁾:**
≤ 80 dB (100 dB typical)
- **Influence of the measurement instrument's impedance Z:**
≤ 0.1% at 10 kΩ

FLEXIBLE PROBES FOR AC CURRENT

Model A110 30-300-3,000-30,000/3

Mechanical specifications

- Clamping capacity:**
Model length 120 cm: Ø max 36 cm
- Bending radius:**
≥ 40 mm
- Operating temperature:**
-10°C to +55°C
- Storage temperature:**
-40°C to +70°C
- Max. temperature of clamped conductor (measured):**
90 °C for 10 minutes max.
- Relative humidity for operation:**
0 to 85 % RH with a linear decrease above 35 °C
- Operating altitude:**
0 to 2,000 m
- Casing protection rating (leakproofing):**
Intermediate casing: IP54
Flexible sensor: IP 67
According to IEC 60529 Ed. 2.2-2013

- Drop test:**
1 m
- Self-extinguishing capability:**
Casing: UL94-V0
Sensor: UL94 V0
- Dimensions:**
Intermediate casing: 120 x 55 x 39 (overall)
Length of intermediate cable linking the sensor/processing unit: 2 m
Length of output cable: 0.5 m
Ø of sensor: 12 mm
Connection cable Ø: 4 mm
- Weight:**
Model length 45 mm: 450 g
Sensor: 30 g / 10 cm
- Colours:**
Sensor: red
Sensor closing system: dark grey
Intermediate casing: Dark grey
- Output:**
Two-wire cable with reinforced or double insulation terminated by 2 red and black isolated male banana plugs Ø 4 mm

Safety specifications

- Electrical safety:**
Class II equipment with double or reinforced insulation between the primary and the secondary (winding connected to the connection cable) as per EN 61010-1 and 61010-2-032 Ed. 03-2012:
- Sensor:
Type B
1,000 V Cat. IV pollution degree 2
Intermediate casing:
600 V Cat. III between the terminals and the external enclosure of the casing
- Electromagnetic compatibility (EMC):** :
Complies with the industrial environments according to EN 61326-1 Ed. 02-2012:
Immunity to radiated fields: at 3 V/m, error ≤ 5% of measuring range (criterion A)

- (1) Conditions of reference: 23 °C ± 5 °K, 20 % to 75 % RH
Battery voltage 3.2 V ± 0.1 VDC
Frequency and form of signal measured: 30 to 440 Hz sinusoidal
Continuous magnetic field < 40 A/m
Absence of external AC magnetic field
Absence of external electrical field
Measured conductor centred in the circular sensor (coil) after operation for 1 minute
Measurement instrument input impedance ≥ 1 MΩ
- (2) With 3,000 mA/h batteries, for a supplied voltage between 3.2 V and 1.8 V (1.6 V to 0.9 V per battery), giving an average voltage of 2.8 V
- (3) Whatever the conductor's position within the loop, as long as the sensor is not distorted (circular sensor)
- (4) Oblong shape
- (5) Adjacent conductor carrying an AC current I_{adj} , in contact with the sensor
- (6) For a 600 V voltage applied between the enclosure and the secondary

3,000 A calibre

Frequency limitation according to amplitude

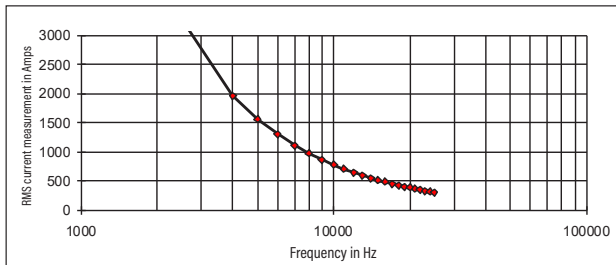

30,000 A calibre

Frequency limitation according to amplitude

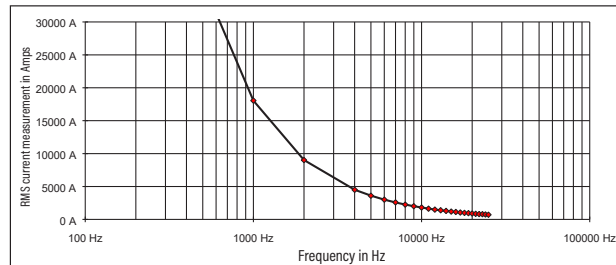

To order		Reference
AmpFlex® A110	30-300-3k-30k A / 3 V, sensor length 120 cm, Output via cable terminated by 2 x Ø 4 mm isolated male banana plugs	P01120632

FLEXIBLE PROBES FOR AC CURRENT

Model A110 30-300-3,000-30,000/3

Frequency response

30 A calibre

Typical error on measurement according to frequency for a current of 2 A

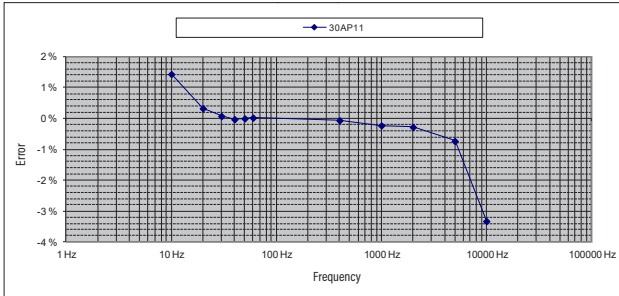

Typical phase shift according to frequency for a current of 2 A

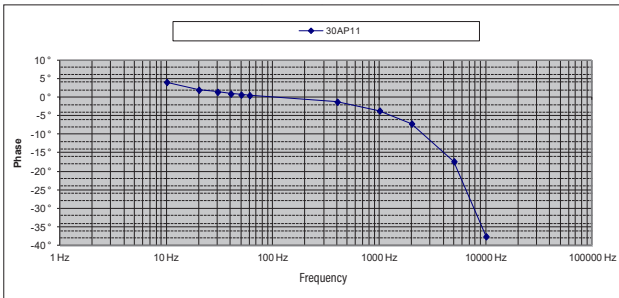

300 A calibre

Typical error on measurement according to frequency for a current of 20 A

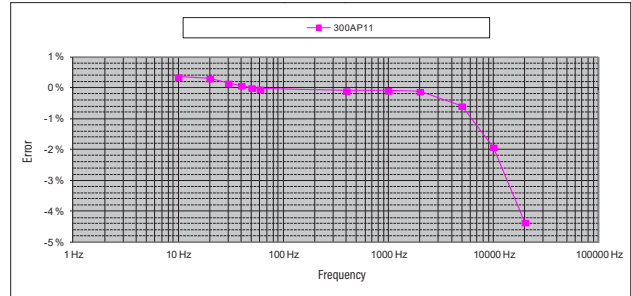

Typical phase shift according to frequency for a current of 20 A

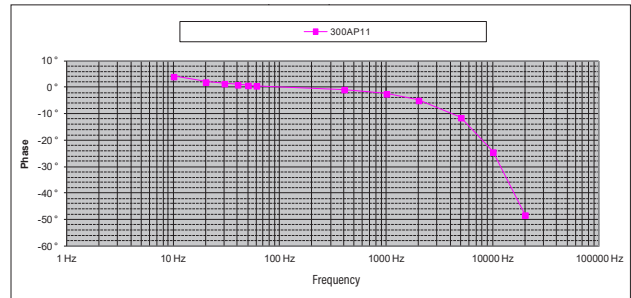

3,000 A calibre

Typical error on measurement according to frequency for a current of 20 A

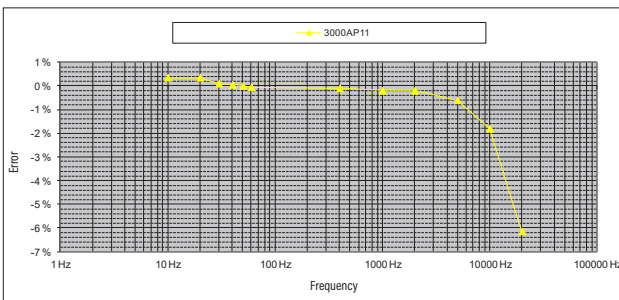

Typical phase shift according to frequency for a current of 20 A

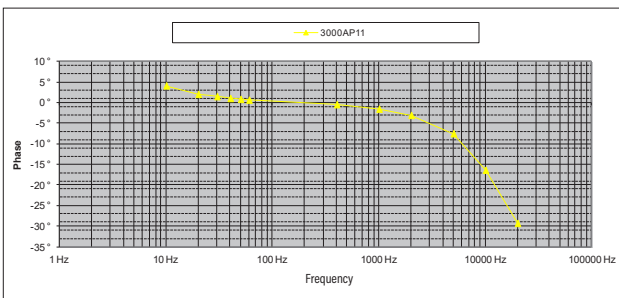

30,000 A calibre

Typical error on measurement according to frequency for a current of 20 A

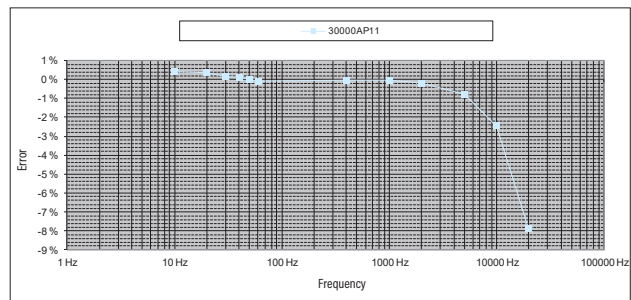

Typical phase shift according to frequency for a current of 20 A

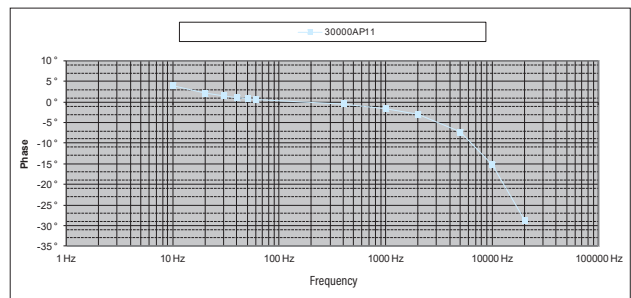

FLEXIBLE PROBES FOR AC CURRENT

Model A130 30-300-3,000/3 Three-phase

Current	30 A AC	300 A AC	3,000 AAC
Output	100 mV/A	10 mV/A	1 mV/A

Description

The AmpFlex® A130 is a flexible sensor which comprises an active part (Rogowski coil) and a casing containing an electronic processing unit.

Unlike current clamps using magnetic circuits, the AmpFlex® models are flexible sensors without magnetic saturation constraints. As a result, they offer excellent linearity, low phase shift, a large dynamic range for measurement (up to several kA) while remaining easy to use.

The sensors' flexibility makes it simple to clamp and measure any conductor, whatever its type (cable, busbar, strand, etc. and accessibility).

The design of the click-together opening and closing system means it can be handled with protective gloves.

The AmpFlex® A130 can be connected to the AC voltage input (mV AC, V AC) of any multimeter or measuring instrument equipped with Ø 4 mm female banana plugs.

The AmpFlex® A130 can be powered by batteries or a standard external power supply. If the power supply fails, the instrument's batteries take over.

To maximize the battery life, the MiniFlex A130 has an automatic standby system which can be deactivated at start-up to perform long-term measurement campaigns. The MiniFlex A130 has 3 green, yellow and red LEDs indicating, respectively, the power supply status, the status of the automatic standby function and any overruns of the measurement capacity.



Specifications for current measurement ⁽¹⁾

Calibre (I _N)	30 A	300 A	3,000 A
Measurement range in use	0.5 .. 30 A AC	0.5 .. 300 A AC	0.5 .. 3,000 A AC
Specified measurement range	5 .. 30 A AC	5 .. 300 A AC	50 .. 3,000 A AC
Output/input ratio	100 mV / A	10 mV / A	1 mV / A
Bandwidth at -3 dB	10 Hz .. 20 kHz	10 Hz .. 20 kHz	10 Hz .. 20 kHz
Frequency limitation	Null	Null	See curve
Intrinsic uncertainty	≤ 1 % + 4 mV	≤ 1.5 % + 0.4 mV (I < 10 % I _N) ≤ 1 % + 0.4 mV (I ≥ 10 % I _N)	≤ 1.5 % + 0.04 mV (I < 10 % I _N) ≤ 1 % + 0.04 mV (I ≥ 10 % I _N)
Phase shift at 50 Hz	≤ 1° (0.5° typical)	≤ 1° (0.5° typical)	≤ 1° (0.5° typical)

Electrical specifications ⁽¹⁾

- **Operating voltage:**
1,000 V_{RMS} (Cat. IV)
- **Battery:**
Two 1.5 V batteries (NEDA 15A, IEC LR6, AA)
+5 V DC via a µUSB Type B connector
- **Battery life ⁽²⁾:**
500 hours typical
3,000 10-minute approx. measurements
- **Consumption:**
10 µA (OFF position)
90 µA (sleep mode)
- **Battery level indication:**
Flashing green LED (batteries voltage > 2 V)
- **Influence of battery voltage:**
≤ 0.1 % (0.02 % typical) from 3.1 V to 2 V
- **Influence of temperature:**
≤ 0.5 % (0.15 % typical) of output signal per 10 °K
- **Influence of relative humidity:**
≤ 0.5 % (0.2 % typical) of output signal
- **Influence of conductor position in the sensor ⁽³⁾:**
≤ 2.5 % (1 % typical)
- **Influence of sensor deformation ⁽⁴⁾:**
≤ 1 % (0.2 % typical)
- **Influence of adjacent conductor ⁽⁵⁾:**
≤ I_{ADJ} x 1 % (2 % near click-lock system)
(0.2 % typical)
- **Input impedance of the measuring instrument:**
≥ 1 MΩ
- **Common mode rejection ⁽⁶⁾:**
≤ 80 dB (100 dB typical)
- **Influence of the measurement instrument's impedance Z:**
≤ 0.1 % at 10 kΩ

FLEXIBLE PROBES FOR AC CURRENT

Model A130 30-300-3,000/3 Three-phase

Mechanical specifications

- Clamping capacity:**
Model length 80 cm: Ø max 23.5 cm
- Bending radius:**
≥ 40 mm
- Operating temperature:**
-10°C to +55°C
- Storage temperature:**
-40°C to +70°C
- Max. temperature of clamped conductor (measured):**
90 °C for 10 minutes max.
- Relative humidity for operation:**
0 to 85 % RH with a linear decrease above 35 °C
- Operating altitude:**
0 to 2,000 m
- Casing protection rating (leakproofing):**
Intermediate casing: IP54
Flexible sensor: IP 67
According to IEC 60529 Ed. 2.2-2013

- Drop test:**
1 m (CEI 68-2-32)
- Self-extinguishing capability:**
Casing: UL94-V0
Sensor: UL94 V0
- Dimensions:**
Intermediate casing: 120 x 55 x 39 (overall)
Length of intermediate cable linking the sensor/ processing unit: 3 m
Length of output cable: 0.5 m
Ø of sensor: 12 mm
Connection cable Ø: 4 mm
- Weight:**
1 kg
- Colours:**
Sensor: red
Sensor closing system: dark grey
Intermediate casing: Dark grey
- Output:**
3 coaxial cables with reinforced or double isolation terminated by 1 black isolated male BNC plug

Safety specifications

- Electrical safety:**
Class II equipment with double or reinforced insulation between the primary and the secondary (winding connected to the connection cable) as per EN 61010-1 and 61010-2-032 Ed. 03-2012:
 - Sensor:
Type B
1,000 V Cat. IV pollution degree 2
Intermediate casing:
600 V Cat. III between the BNC output and the external enclosure of the casing
- Electromagnetic compatibility (EMC):** :
Complies with the industrial environments according to EN 61326-1 Ed. 02-2012:
 - Immunity to radiated fields: at 3 V/m, error ≤ 5% of measuring range (criterion A)

- Conditions of reference: 23 °C ± 5 °K, 20 % to 75 % RH
Battery voltage 3.2 V ± 0.1 VDC
Frequency and form of signal measured: 30 to 440 Hz sinusoidal
Continuous magnetic field < 40 A/m
Absence of external AC magnetic field
Absence of external electrical field
Measured conductor centred in the circular sensor (coil) after operation for 1 minute
Measurement instrument input impedance ≥ 1 MΩ
- With 3,000 mA/h batteries, for a supplied voltage between 3.2 V and 1.8 V (1.6 V to 0.9 V per battery), giving an average voltage of 2.8 V
- Whatever the conductor's position within the loop, as long as the sensor is not distorted (circular sensor)
- Oblong shape
- Adjacent conductor carrying an AC current I_{adj} , in contact with the sensor
- For a 600 V voltage applied between the enclosure and the secondary
- Delivered with a set of 3 female BNC/ Ø 4 mm isolated male banana adapters with 19 mm spacing and a set of identifiers (12 colours)

3,000 A calibre

Frequency limitation according to amplitude

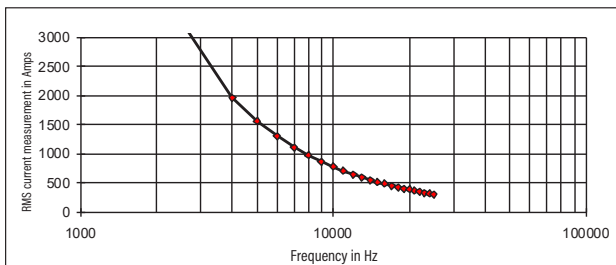

To order	Reference
AmpFlex® A130 30-300-3,000 A / 3 V, sensor length 80 cm, output via 3 coaxial cables terminated by 1 isolated security BNC lead ⁽⁷⁾	P01120633

FLEXIBLE PROBES FOR AC CURRENT

Model A130 30-300-3,000/3 Three-phase

Frequency response

30 A calibre

Typical error on measurement according to frequency for a current of 20 A

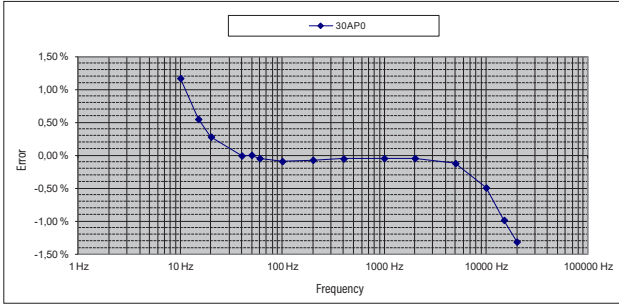

300 A calibre

Typical error on measurement according to frequency for a current of 20 A

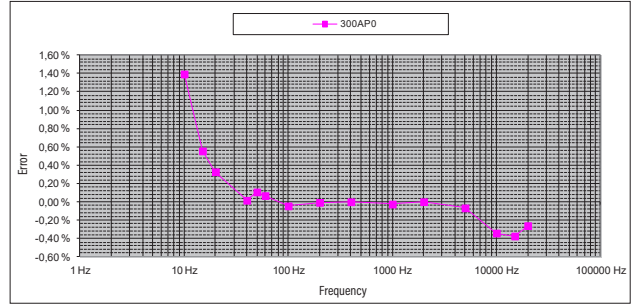

Typical phase shift according to frequency for a current of 20 A

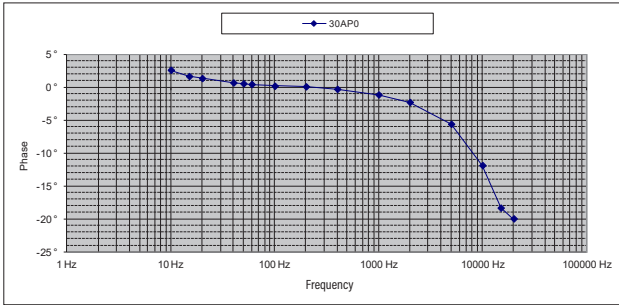

Typical phase shift according to frequency for a current of 20 A

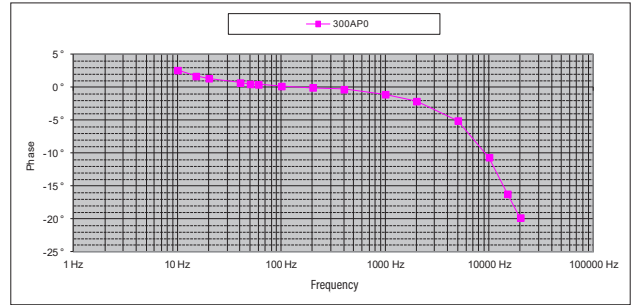

3,000 A calibre

Typical error on measurement according to frequency for a current of 20 A

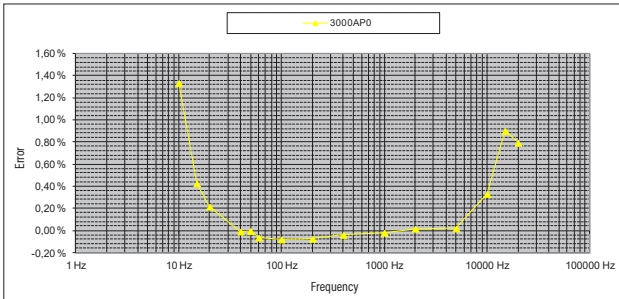

Typical phase shift according to frequency for a current of 20 A

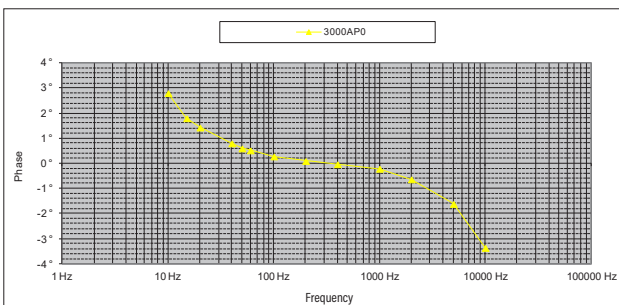

CURRENT CLAMPS FOR AC/DC CURRENT



E series

The E series is designed for the measurement of alternating and direct currents using Hall-effect technology. Currents are measured from a few milliamperes to over 100 A.

The slim, elongated shape of these clamps allows them to take measurements in cable strands or confined spaces such as switchboard wiring, motor controls and automotive electrical circuits.

Their low phase shift ensures excellent performance for power measurement.

These clamps feature a voltage output (mV). Their ability to measure AC+DC signals is valued for True RMS measurements.

The E25 model offers the highest sensitivity for measurements of weak current. This clamp can be connected to multimeters, loggers, data acquisition systems, etc.

The E27 model can be connected directly to an oscilloscope.

CURRENT CLAMPS FOR AC/DC CURRENT

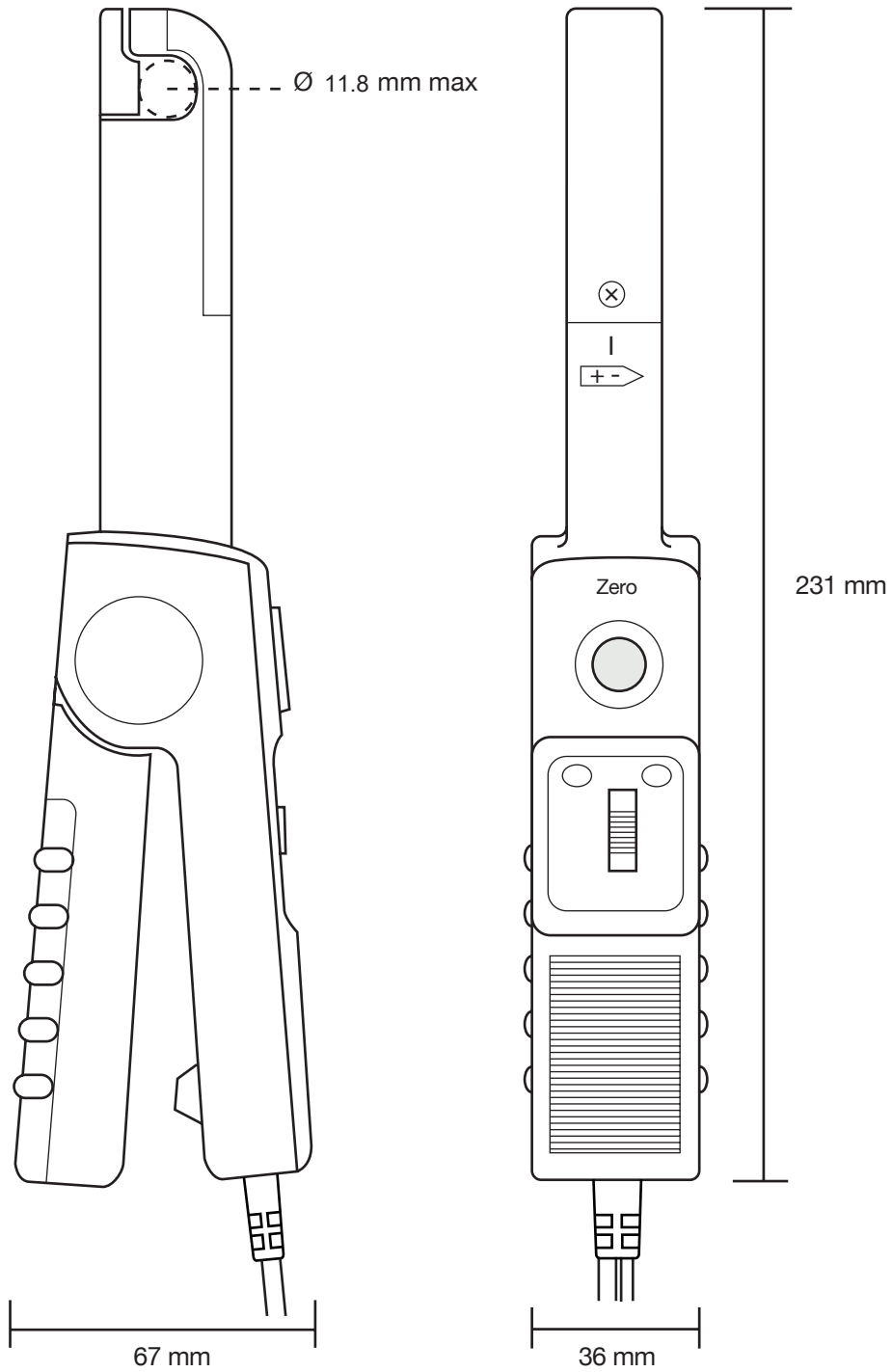

CURRENT CLAMP FOR AC/DC CURRENT

Model E25

Current	2 A DC - 1.5 A AC	80 A DC - 60 A AC
Output	1 mV/mA	10 mV/A

Description

The E25 clamp meter is designed to measure AC and DC currents using Hall-effect technology. Its slim, elongated shape allows it to take measurements in confined or hard-to-reach spaces. Via a lead terminated with two insulated Ø4 mm male banana leads, this clamp meter outputs an mV AC+DC signal that mirrors the shape and amplitude of the measured current.

The E25 clamp is equipped with an automatic DC zero system and a disengageable standby mode (Auto Power Off (APO)). It can be powered by a battery or a standard mains adapter via a Micro USB connector and offers two different sensitivity settings.



Electrical specifications

- Current range:**
5 mA .. 80 A DC / 60 A AC across 2 calibres
- Accuracy and phase shift ⁽¹⁾:**

Calibre	1 mV/mA (1 V/A)		10 mV/A	
	5 mA .. 2 A DC 5 mA .. 1.5 A AC	50 mA .. 50 A DC 50 mA .. 40 A AC	50 A .. 80 A DC 40 A .. 60 A AC	
Primary current:				
Accuracy in % of output signal	≤ 2 % + 5 mV	≤ 4% + 500 μV	≤ 12 %	
Phase shift	≤ 1° (DC .. 65 Hz)	≤ 1° (DC .. 65 Hz)	≤ 1° (DC .. 65 Hz)	
Noise ⁽²⁾	DC: 8 mV DC AC: 4 mV AC _{RMS}	DC: 120 μV DC AC: 180 μV AC _{RMS}	DC: 120 μV DC AC: 180 μV AC _{RMS}	

- Output signal:**
1 mV AC+DC / mA AC+DC (2 V at 2 A)
10 mV AC+DC / A AC+DC (0.8 V at 80 A)
- Bandwidth:**
DC .. 20 kHz (-3 dB) (depending on current value)
- DC zero adjustment:**
Automatic adjustment of current sensitivity at the touch of a button
- Typical output noise level (peak-to-peak) from DC to 100 kHz:**
 - 2 A calibre: 4 mV_{RMS} / 8 mV DC
 - 80 A calibre: 180 μV_{RMS} / 120 μV DC
- Power supply:**
9 V alkaline (NEDA 1604A, IEC 6LR61)
5 V DC via a μUSB connector
- Battery life:**
80 hours typical (alkaline battery)
- "ON" LED indicator (3):**
"On" = In operation & battery level OK
"Flashing" = Battery life < 4 hours
"Colour = green" = APO ON
"Colour = yellow" = APO OFF
- "OL" LED indicator:**
Overload indication; current measured is too high for the calibre being used.
- Influence of temperature:**
≤ 800 ppm/°C, 10 mA DC/°C
- Influence of relative humidity:**
≤ 0.5% at 10% to 85% RH at ambient temperature
- Influence of conductor position in jaws:**
≤ 0.5 %
- Common-mode voltage (600 V max) during AC measurement (max):**
at 50/60 Hz: ≤ 1 mA/100 V
- Remanence:**
at 80 A DC: 370 mA DC typical
- Relative humidity for operation:**
0 to 85 % RH with a linear decrease above 35 °C
- Operating altitude:**
0 to 2,000 m
- Casing protection rating:**
IP 20 (IEC 60529)
- Drop test:**
1 m (IEC 60068-2-31)
- Colours:**
Dark grey/Red

Mechanical specifications

- Clamping capacity:**
Cable: Ø max 11.8 mm
- Output:**
1.5 m two-wire cable terminated with two insulated male Ø4 banana leads
- Dimensions:**
231 x 67 x 36 mm
- Mass:**
330 g with battery
- Operating temperature:**
-10° at +50°C
- Storage temperature:**
-30° at +80°C

Safety specifications

- Electrical safety:**
Type A instrument, with double insulation or reinforced insulation between the primary, the secondary and the grippable part located under the guard as per IEC 61010-1 & IEC 61010-2-032
 - 600 V category III, pollution degree 2
 - 300 V category IV, pollution degree 2
- Electromagnetic compatibility (EMC) :**
Compliant with IEC 61326-1: 2013 (portable instrument) with field strengths of 10 V/m:
 - ≤ 4 A DC @[80MHz, 1GHz]

CURRENT CLAMP FOR AC/DC CURRENT

Model E25

Curves

80 A calibre

Linearity for DC

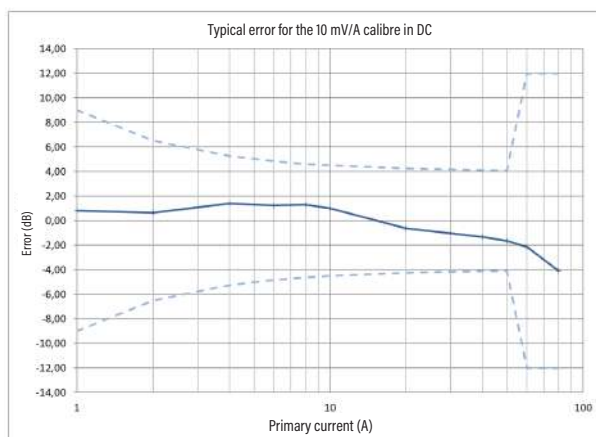

Linearity for AC

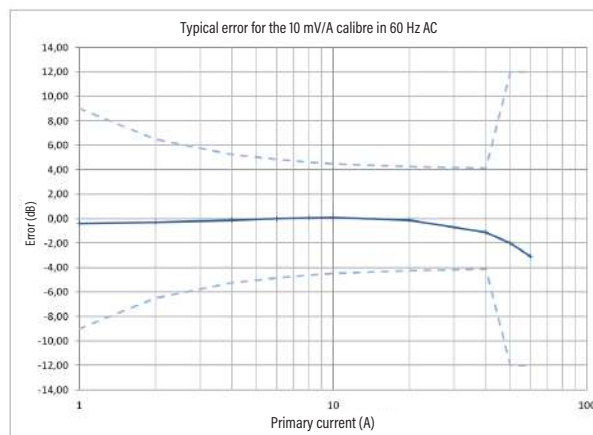

2 A calibre

80 A calibre

Frequency response

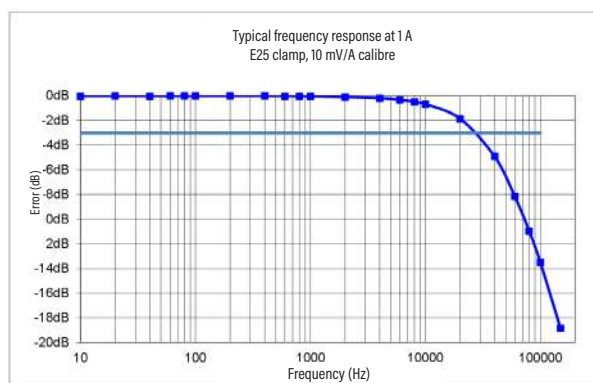
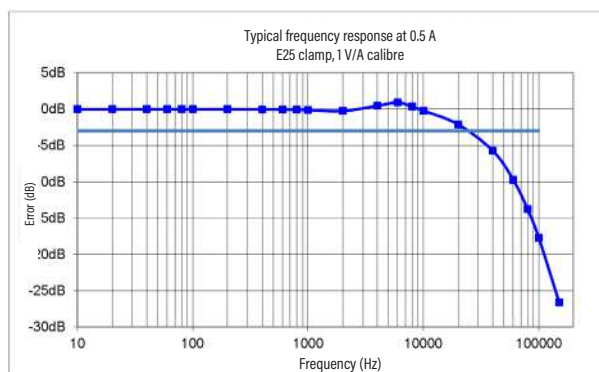

Frequency phase shift

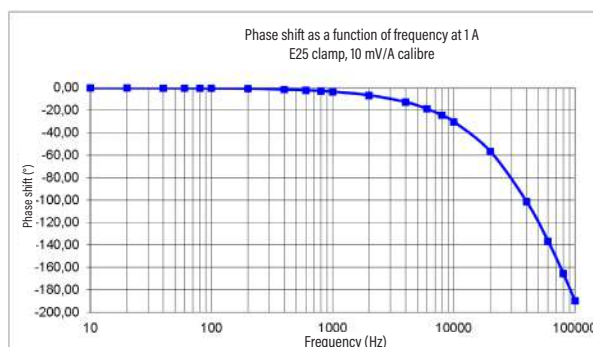
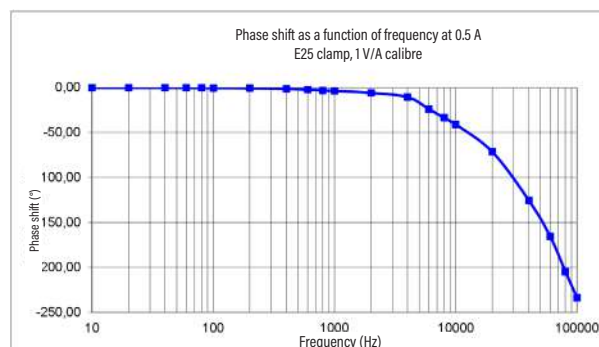

CURRENT CLAMP FOR AC/DC CURRENT

Model E25

Curves

2 A calibre

80 A calibre

Pulse response

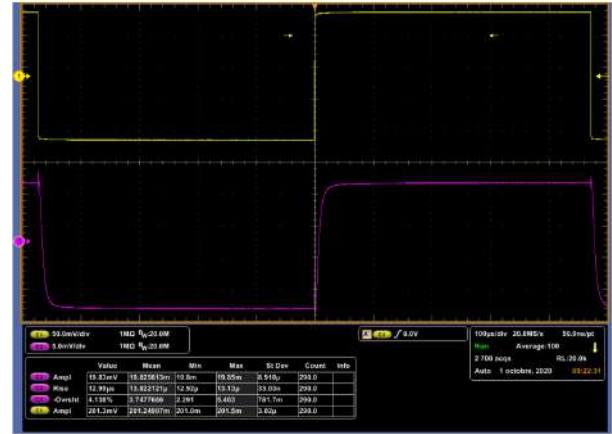

Limitation of the measurable current as a function of frequency

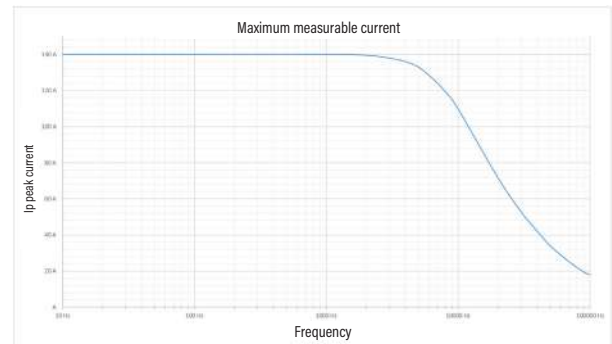

- (1) Conditions of reference: 23°C ± 5°K, 20-75% RH, power supply voltage 6.5 V DC to 9.0 V DC, sinusoidal signal with a frequency of DC to 1 kHz, external magnetic field < 40 A/m, no DC components, no external conductor with circulating current, conductor centred for measurement, load impedance ≥ 1 MΩ / ≤ 100 pF.
- (2) Typical value(s)
- (3) With an alkaline battery, without an external power supply

To order	Reference
AC/DC current probe, model E25 , with battery and user manual	P01120025

CURRENT CLAMP FOR AC/DC CURRENT

Model E27 (insulated AC/DC current probe)

Current	10 A peak	100 A peak
Output	100 mV/A	10 mV/A

Description

The E27 clamp meter is designed to measure AC and DC currents using Hall-effect technology. Its narrow, elongated shape allows it to take measurements within cable strands or in confined spaces such as switchboard wiring, motor controls or power supplies, and automotive electrical circuits.

This clamp provides an output signal in mV that mirrors the shape and amplitude of the measured current, via a coaxial lead terminated with an insulated BNC lead.

The E27 clamp is equipped with an automatic DC zero system, a disengageable standby mode (Auto Power Off (APO)), and can be powered by a standard mains adapter via a micro-USB connector.

This clamp offers two different sensitivity settings and a wide bandwidth. It is valued for performing measurement and display of complex AC+DC signals on an oscilloscope.



Electrical specifications

- Current range:**
0.1 .. 10 A peak
0.5 .. 100 A peak
- Accuracy and phase shift ⁽¹⁾:**

Calibre	10 A		100 A	
	Primary current:	100 mA .. 10 A peak	500 mA .. 40 A peak	40 A .. 100 A peak
Accuracy in % of output signal	< 3% + 5 mV	< 4% + 500 µV	< 15%	
Phase shift	≤ 1.5°	≤ 1°	≤ 1°	

- Output signal:**
100 mV AC+DC / A AC+DC (1 V at 10 A)
10 mV AC+DC / A AC+DC (1 V at 100 A)
- Bandwidth:**
DC .. 100 kHz (-3 dB) (depending on current value)
- Rise time (10% to 90%) and fall time (90% to 10%):**
 - 10 A calibre: 3 µs
 - 100 A calibre: 3 µs
- 10 % delay time:**
 - 10 A calibre: 1.8 µs
 - 100 A calibre: 1.8 µs
- Insertion impedance (at 10 kHz / 50 kHz)**
≤ 2 mΩ / ≤ 10 mΩ
- DC zero adjustment:**
Automatic adjustment of current sensitivity at the touch of a button
- Typical output noise level (peak-to-peak) from DC to 100 kHz:**
 - 10 A calibre: 5 mV_{peak-peak}
 - 100 A calibre: 600 µV_{peak-peak}
- Power supply:**
9 V alkaline (NEDA 1604A, IEC 6LR61)
5 V DC via a µUSB connector
- Battery life:**
80 hours typical (alkaline battery)
- "ON" LED indicator ⁽²⁾:**
"On" = In operation & battery level OK
"Flashing" = Battery life < 4 hours
"Colour = green" = APO ON
"Colour = yellow" = APO OFF
- "OL" LED indicator:**
Overload indication; current measured is too high for the calibre being used.
- Influence of temperature:**
≤ 800 ppm/°C, 10mA DC/°C
- Influence of relative humidity:**
≤ 0.5% at 10% to 85% RH at ambient temperature
- Influence of adjacent conductor:**
≤ 4 mA/A @60Hz
- Influence of conductor position in jaws:**
≤ 0.5 % of output signal at 1 kHz
- Common-mode voltage (600 V max) during AC measurement (max):**
at 50/60 Hz: ≤ 1 mA/100 V
at 400 Hz: ≤ 7 mA/100 V
- Remanence:**
at 100 A DC: 450 mA DC typical

Mechanical specifications

- Clamping capacity:**
Cable: Ø max 11.8 mm
- Output:**
Coaxial cable 2 m long, terminated by an insulated BNC connector
- Dimensions:**
231 x 67 x 36 mm
- Mass:**
330 g with battery

- Operating temperature:**
-10° at +50°C
- Storage temperature:**
-30° at +80°C
- Relative humidity for operation:**
0 to 85% RH with a linear decrease above 35 °C
- Operating altitude:**
0 to 2,000 m
- Casing protection rating:**
IP 20 (IEC 60529)
- Drop test:**
1 m (IEC 60068-2-31)
- Colours:**
Dark grey/Red

Safety specifications

- Electrical safety:**
Type A instrument, with double insulation or reinforced insulation between the primary, the secondary and the grippable part located under the guard as per IEC 61010-1 & IEC 61010-2-032
 - 600 V category III, pollution degree 2
 - 300 V category IV, pollution degree 2
- Electromagnetic compatibility (EMC) :**
Compliant with IEC 61326-1: 2013 (portable instrument) with field strengths of 10 V/m on the 100 mV/A calibre:
 - ≤ 400 mA DC @[80MHz, 280MHz]
 - ≤ 2 A DC @[280MHz, 460MHz]
 - ≤ 400 mA DC @[460MHz, 1GHz]

CURRENT CLAMP FOR AC/DC CURRENT

Model E27 (insulated AC/DC current probe)

Curves

100 A calibre

Linearity for DC

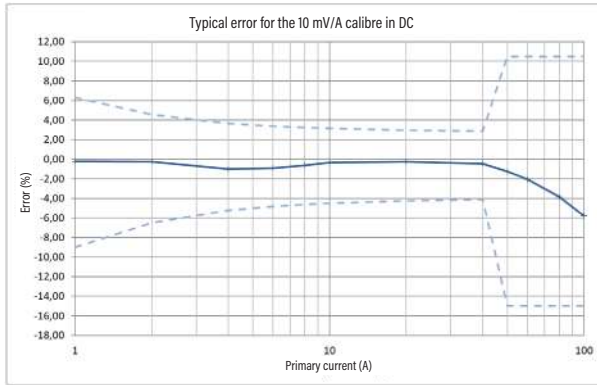

Linearity for AC

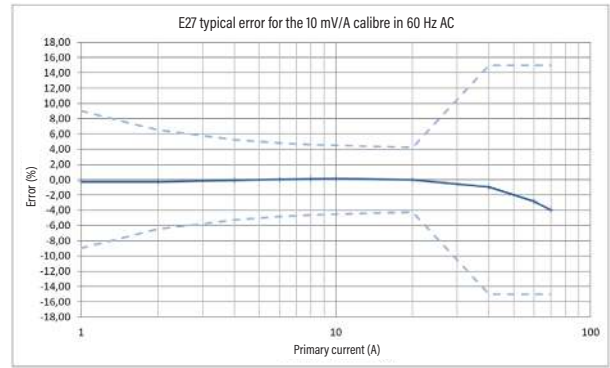

10 A calibre

100 A calibre

Frequency response

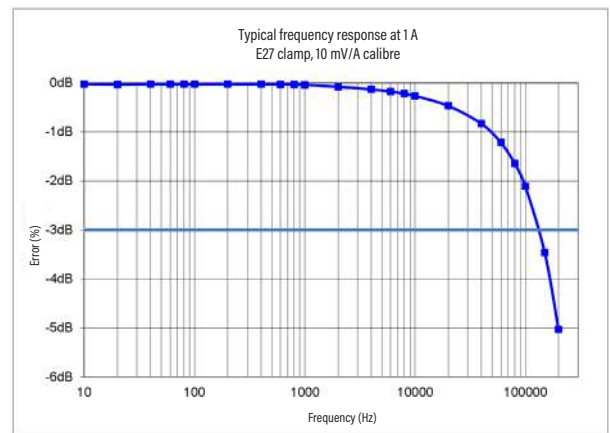
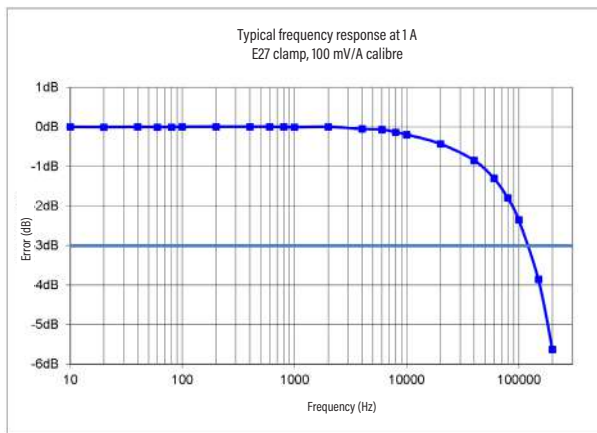

Frequency phase shift

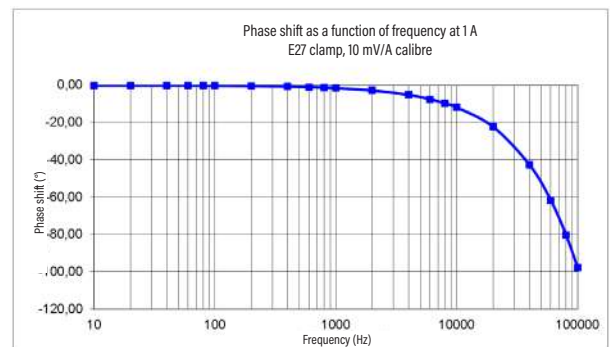
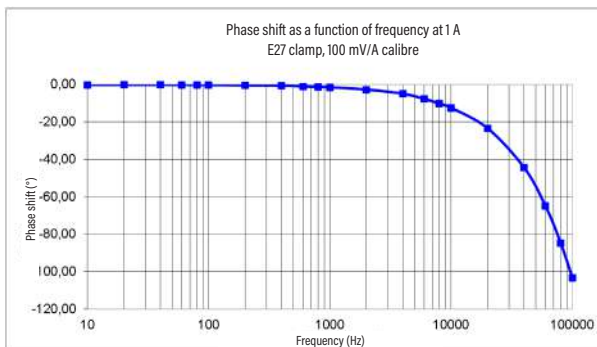

CURRENT CLAMP FOR AC/DC CURRENT

Model E27 (insulated AC/DC current probe)

Curves

10 A calibre

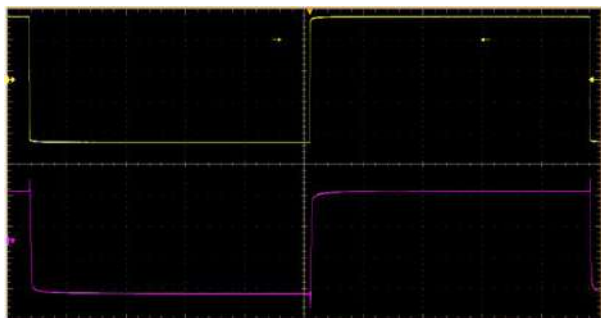

100 A calibre



Pulse response

Limitation of the measurable current as a function of frequency

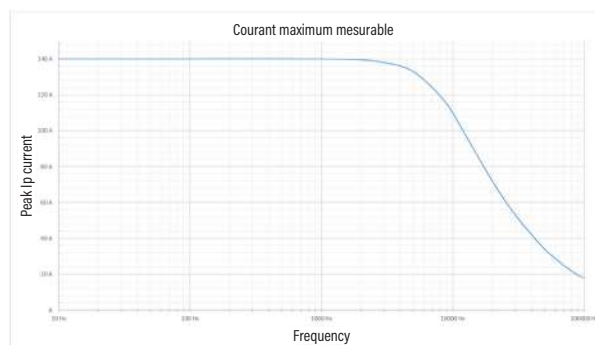

- (1) Conditions of reference: 23°C ± 5°K, 20-75% RH, power supply voltage 6.5 V DC to 9.0 V DC, sinusoidal signal with a frequency of DC to 1 kHz, external magnetic field < 40 A/m, no DC components, no external conductor with circulating current, conductor centred for measurement, load impedance ≥ 1 MΩ / ≤ 100 pF.
- (2) With an alkaline battery, without an external power supply

To order	Reference
AC/DC current clamp, model E27 , for oscilloscopes, with battery and operating user manual	P01120027

CURRENT CLAMP FOR AC/DC CURRENT



MH series

The MH60 clamp is designed to measure DC and AC currents up to 1MHz using dual Hall effect/Transformer technology.

It includes an internal NiMh rechargeable battery and can be recharged or powered using a 5 V DC power supply via the female type-B μUSB connector with which it is equipped.

It has an automatic standby system (which can be deactivated), an automatic "DC zero" system for compensation of magnetic and electronic drift, a switchable selective filter (3 kHz, 30 kHz) and a system for compensating the effects of the earth field and other constant DC fields.

Its ability to measure AC+DC signals is useful for True RMS measurements.

CURRENT CLAMP FOR AC/DC CURRENT

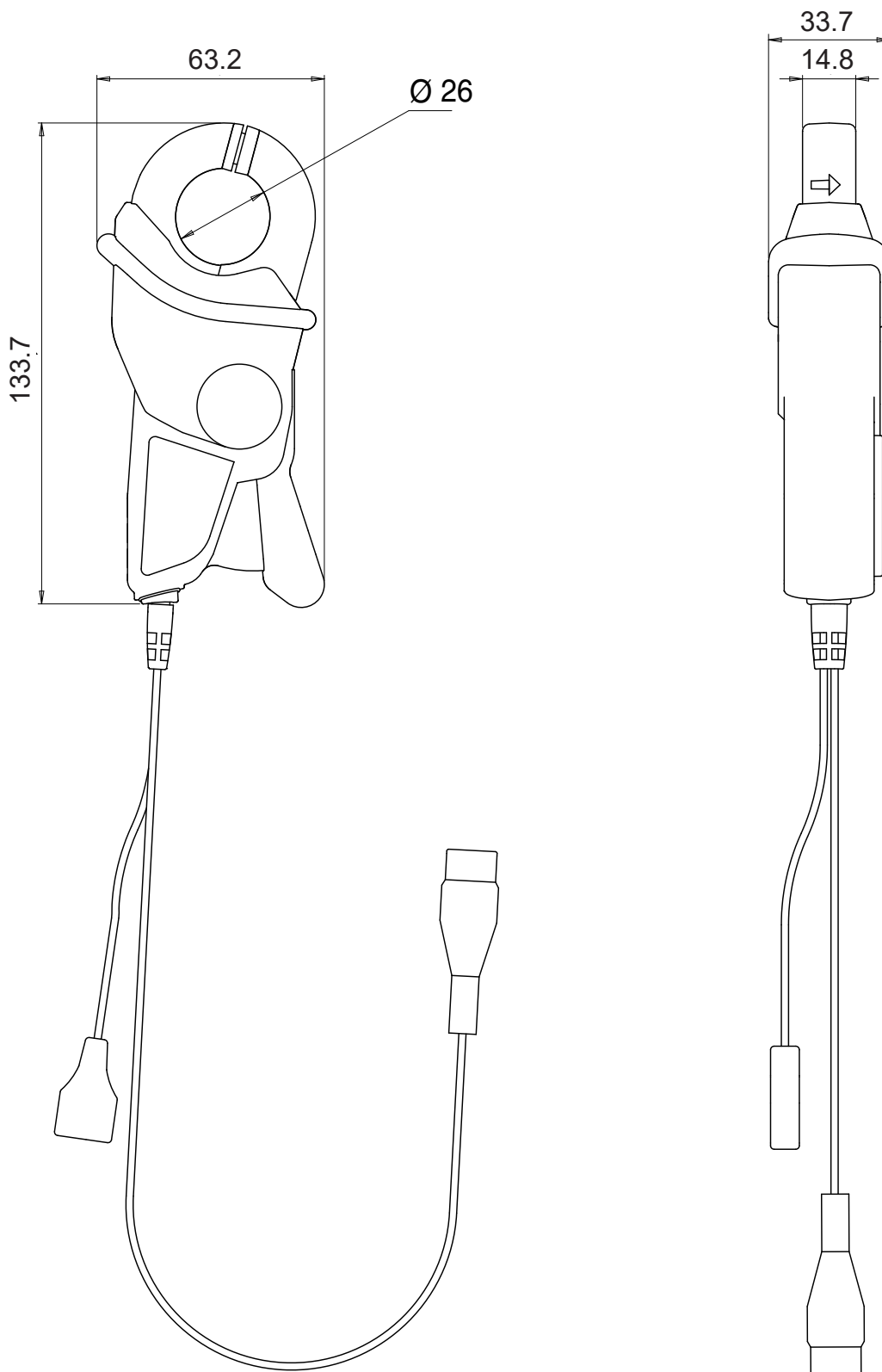

CURRENT CLAMP FOR AC/DC CURRENT

Model MH60 (insulated AC/DC current probe)

Current	140 A peak
Output	10 mV / A

Description

The MH60 clamp is designed to measure DC and AC currents up to 1MHz using dual Hall effect/Transformer technology.

Electrical specifications

- Current range:**
0.5 .. 100 A DC (140 A peak)
- Output signal:**
10 mV AC+DC / A AC+DC (1 V at 100 A)
- Accuracy and phase shift ⁽¹⁾:**

Primary current:	0 to 60 A _{peak} (0 to 42 ARMS or DC)	60 to 90 A _{peak} (42 to 64 ARMS or DC)	90 to 110 A _{peak} (64 to 80 ARMS or DC)	110 to 140 A _{peak} (80 to 100 ARMS or DC)
Accuracy in % of output signal	≤ (1.5 % ± 0.1 mV)	≤ 2.5 %	4 %	6 %
Phase shift @ 50 Hz	≤ 1°			

- Bandwidth:**
DC .. 1 MHz (-3 dB) (depending on current value)
- Rise time and fall time:**
From 10% to 90%
Without filter: 350 ns
With filter 30 kHz: 11.7 μs
With filter 3 kHz: 117 μs
- dl/dt @ 2 A peak-peak:**
5 A / μs
- Delay time @ 2 A peak-peak:**
0.35 μs typical
- Insertion impedance:**
~ 0.25 mΩ @ 400 Hz
~ 0.628 mΩ @ 1 MHz
- DC zero adjustment:**
±3 A by push-button
- Noise RMS:**
Without filter: 15 mA typical (< 88 mA peak-peak)
30 kHz filter: 5 mA typical (< 36.6 mA peak-peak)
3 kHz filter: 4 mA typical (< 35.8 mA peak-peak)
- Power supply:**
Internal NiMH rechargeable battery + 5 V DC external via female μUSB type B connection
- Battery life:**
8 hours typical with fully-charged battery
- Typical consumption:**
< 150 mA (battery charging)
- Low battery signal:**
Flashing green LED x 2 hours
- Overload indication:**
RED "OL" LED to indicate excessive measurement current



- Influence of temperature:**
-10 °C .. +45 °C: ≤ 1200 ppm / °C
+45 °C .. +50 °C: ≤ 2200 ppm / °C
- Influence of conductor position in jaws:**
≤ 1.5 % of output signal
- Common mode voltage (600 V max) for AC measurements (typical/max):**
at 50 Hz: 3.5 mA/5 mA @ 100 V
at 400 Hz: 25.9 mA/50 mA @ 100 V

Mechanical specifications

- Clamping capacity:**
Cable: Ø max 26 mm
- Max. jaw insertion capacity:**
≤ 90 °C
- Output:**
Coaxial cable 2 m long, terminated by an insulated BNC connector
- Dimensions:**
138 x 49 x 28 mm
- Mass:**
Approximately 200 g
- Operating temperature:**
-10 °C to +50 °C
- Storage temperature:**
-20 °C to +50 °C
- Relative humidity for operation:**
0 to 85 % RH with a linear decrease above 35 °C
- Operating altitude:**
0 to 2,000 m

- Casing protection rating:**
IP 40 (EN 60529)
- Drop test:**
1 m (EN 60068-2-32)
- Shock resistance:**
100 g / 6 ms / half-period (CEI 68-2-27)
- Vibration resistance:**
10/55/10 Hz, 0.15 mm (CEI 68-2-6)
- Self-extinguishing capability:**
UL94 V2
- Colours:**
Dark grey case with red jaws

Safety specifications

Type A clamp with double insulation or reinforced insulation between the primary, the secondary and the grippable part located under the guard as per CEI 61010-1 & CEI 61010-2-032

- 600 V category III, pollution degree 2
- 300 V category IV, pollution degree 2
- Electromagnetic compatibility (EMC) :**
Emission according to EN 50081-1: class B
Immunity according to EN 50082-2:
 - Electrostatic discharge (IEC 1000-4-2):
4 kV level 2 performance criterion B
8 kV in the air level 3 performance criterion B
 - Radiated field (IEC 1000-4-3):
10 V/m performance criterion A
 - Fast transients (IEC 1000-4-4):
1 kV level 2 performance criterion B
2 kV level 3 performance criterion B
 - Magnetic field at the network frequency (IEC 1000-4-8): field of 400 A/m at 50 Hz: < 1 A

(1) Conditions of reference: 23 °C ± 5 °K, 20 at 75% RH, power supply voltage 5 V ± 5% V DC sinusoidal signal with frequency of DC at 400 Hz, external magnetic field < 40 A/m, no DC components, no external conductor with circulating current, conductor centred for measurement, load impedance > 1 MΩ / < 100 pF.

(2) Without filter.

To order	Reference
AC/DC clamp model MH60 with a 100 V-240 V 50/60 Hz mains adapter, 1.5 A USB-A, type-A male USB ⇔ type-B male μUSB cable 1.80 m long, verification certificate and 5-language user manual	P01120612

CURRENT CLAMP FOR AC/DC CURRENT

Model MH60 (insulated AC/DC current probe)

Curves

Linearity in DC 100 A calibre

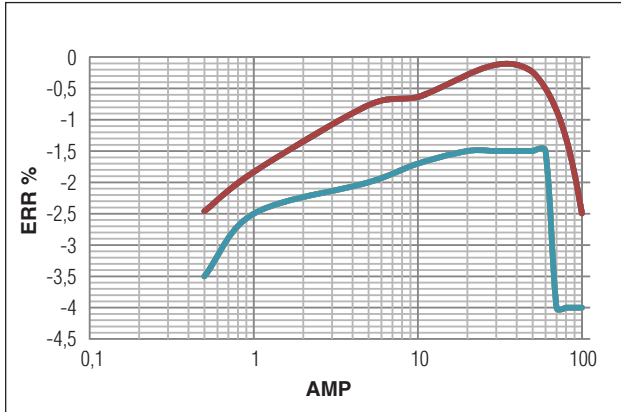

Frequency response at 0.5 A

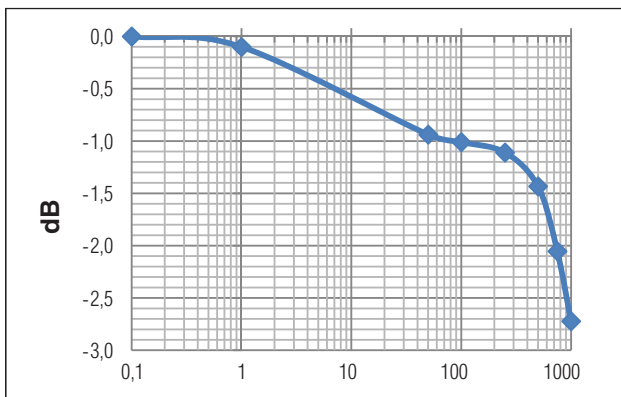

Insertion impedance

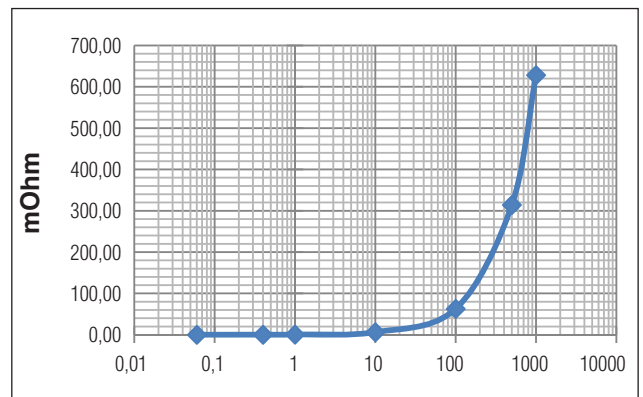

Phase shift at 3 A

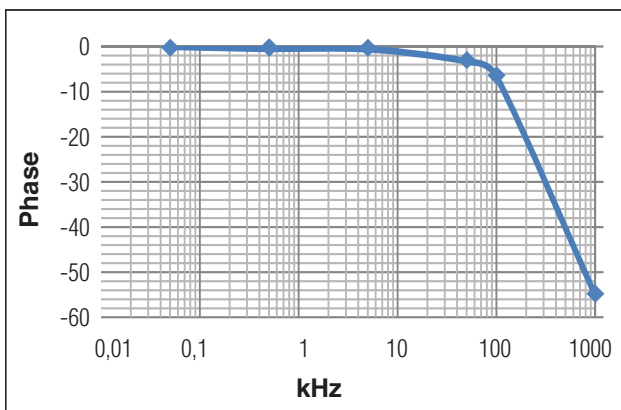

Limitation of measurable current according to the frequency

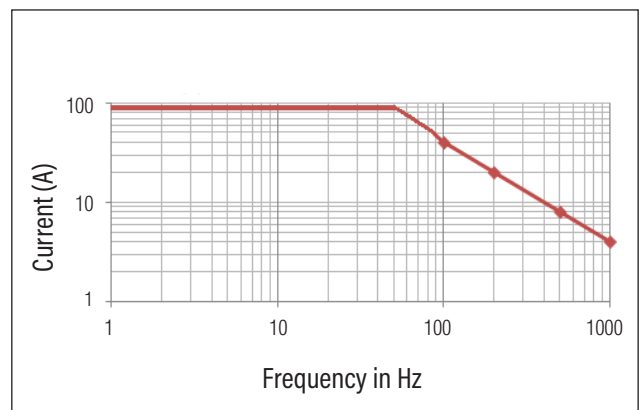

CURRENT CLAMP FOR AC/DC CURRENT

Model MH60 (insulated AC/DC current probe)

Curves

1 A peak

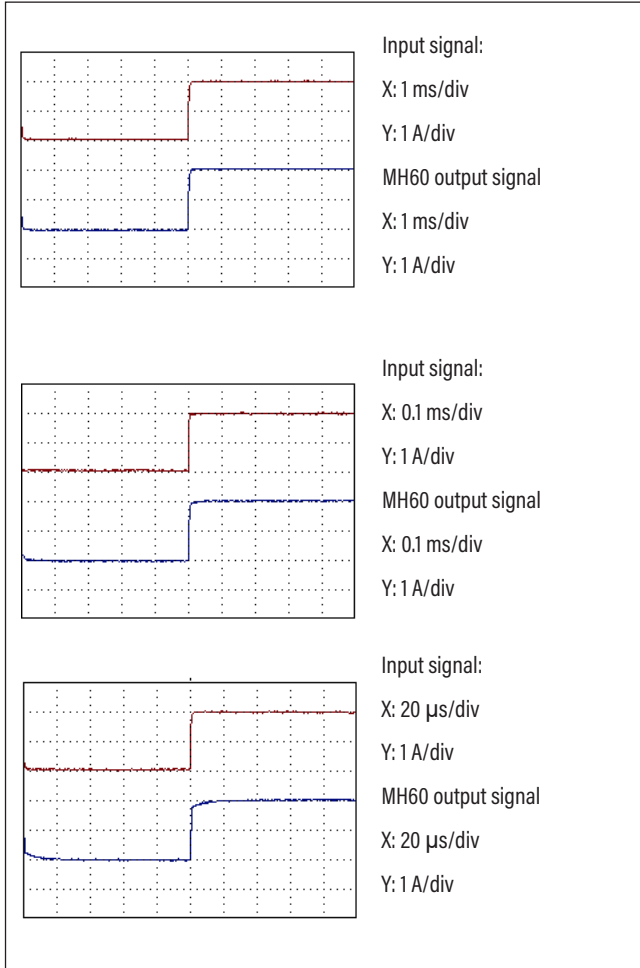

2 A peak

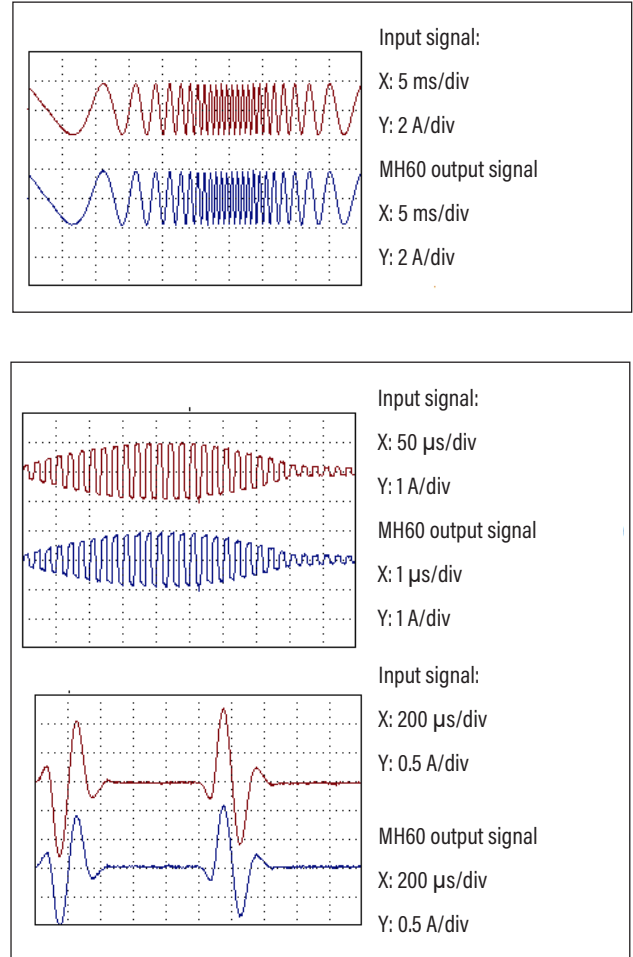

0.1 A peak

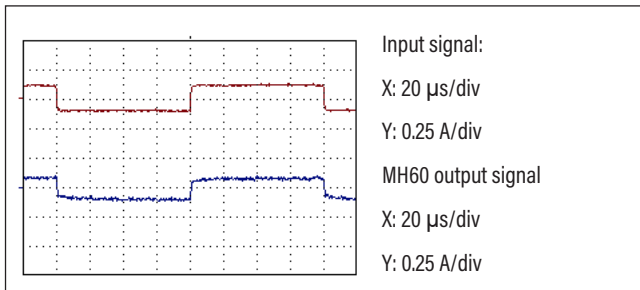

NOTES

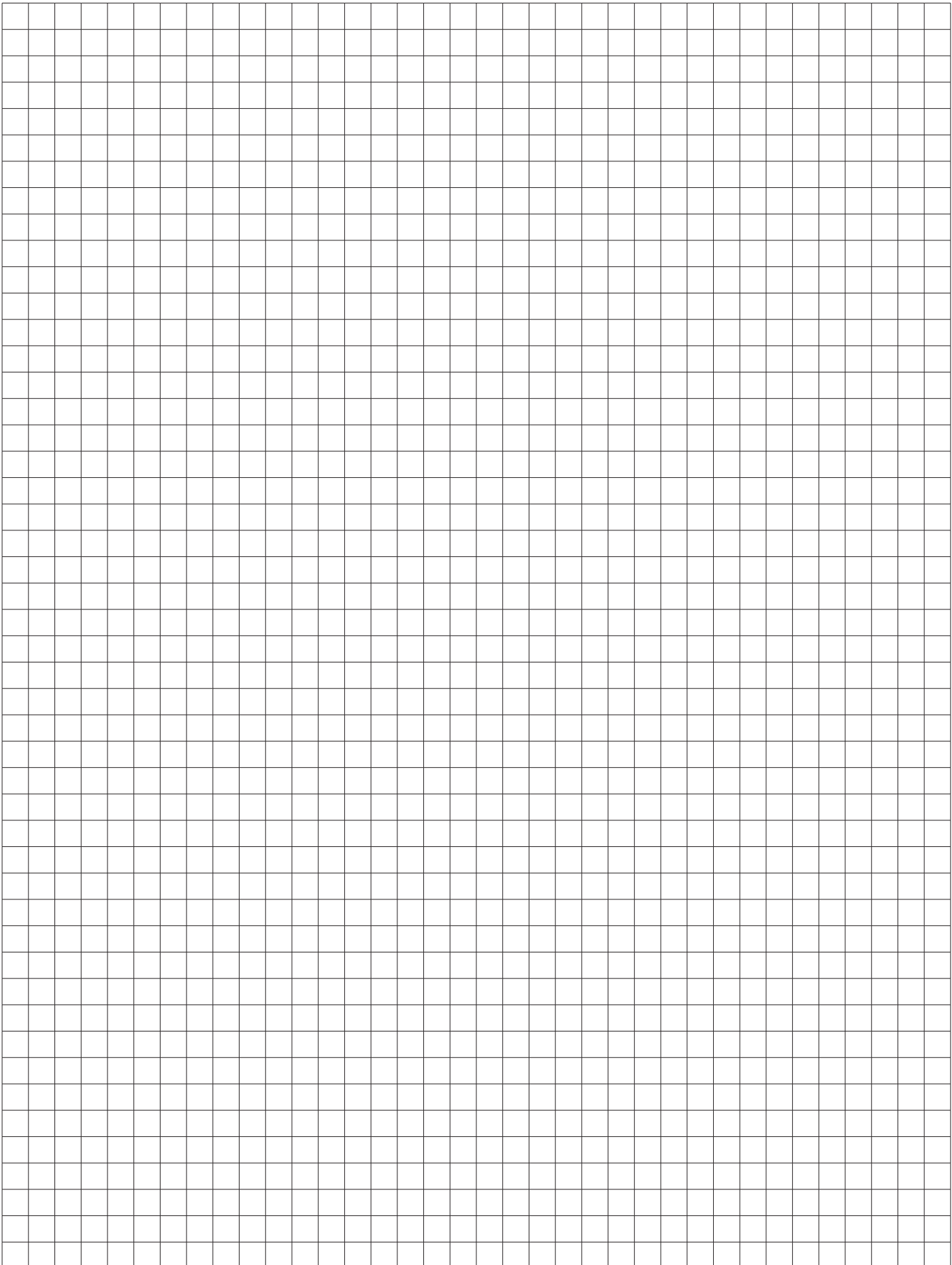

CURRENT CLAMP FOR AC/DC CURRENT



PAC series

PAC clamps are professional current clamps designed to measure both AC and DC currents. The two jaw shapes available allow the user to clamp onto leads as well as small busbars.

Using the Hall effect principle, models in the PAC 10 series measure up to 400 A AC and 600 A DC, whilst those in the PAC 20 series reach 1,000 A AC and 1,400 A DC.

Powered by a battery or an optional standard external power supply via their micro USB connector, the PAC clamps all feature automatic DC zero adjustment and an automatic standby mode (Auto Power Off (APO)) that is disengageable.

The PAC 15 and PAC 25 models have a single measurement range with a sensitivity of 1 mV/A, allowing a so-called "direct" reading on the associated multimeter.

The PAC 16 and PAC 26 models feature a second, more sensitive 10 mV/A calibre.

The PAC 17 and PAC 27 models, also known as "isolated current probes", are dual-range and equipped with a coaxial lead and an isolated BNC connector so that they can be connected directly to an oscilloscope, allowing the current to be displayed in terms of both waveform and amplitude.

CURRENT CLAMPS FOR AC/DC CURRENT

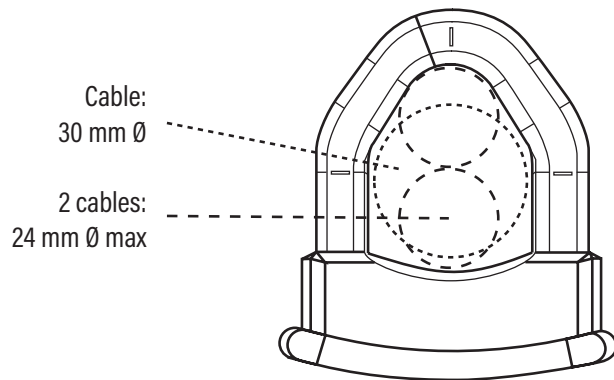

Cable:
30 mm Ø

2 cables:
24 mm Ø max

Jaws
PAC15, 16 and 17

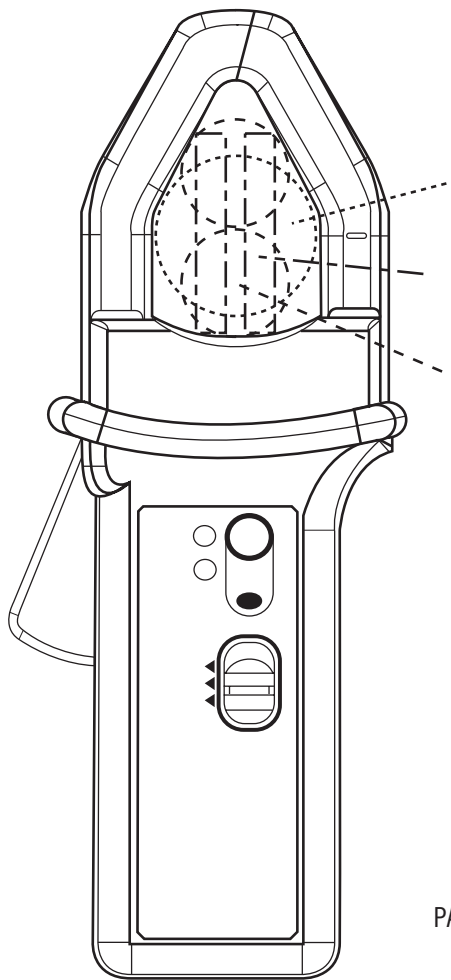

Cable:
39 mm max Ø

2 busbars:
50 x 5 mm max

2 cables:
25 mm max Ø

PAC 25, 26 and 27

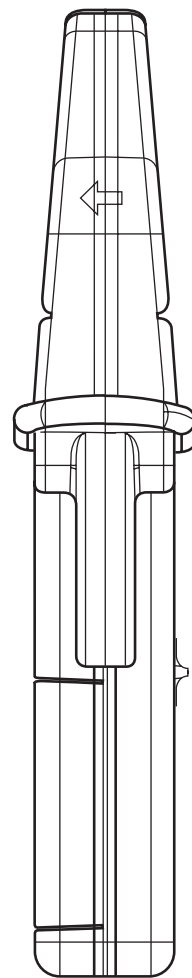

224 mm
(PAC 15, 16 and 17)

236,5 mm
(PAC 25, 26 and 27)

97 mm

44 mm

CURRENT CLAMP FOR AC/DC CURRENT

Model PAC15

Current	400 A AC 600 A DC
Output	1 mV/A

Description

The PAC15 model provides accurate measurement of AC or DC currents using the Hall effect principle. This mV-output clamp meter is equipped with an automatic DC zero system and a disengageable Auto Power Off (APO) function, and can be powered by a standard mains adapter via a Micro USB connector.

Electrical specifications

- Current range:**
0.5 A AC .. 400 A AC (600 A peak) / 0.5 A DC .. 600 A DC
- Output signal:**
1 mV AC+DC / A AC+DC (0.6 V for 600 A)
- Accuracy and phase shift ⁽¹⁾:**

Primary current:	0.5 A .. 3 A	3 A .. 100 A	100 A .. 300 A	300 A .. 400 A	400 A .. 500 A (DC only)	500 A .. 600 A (DC only)
Accuracy in % of output signal	≤ 2 % + 1.5 mV	≤ 2 % + 1.5 mV	≤ 2 %	≤ 2 %	≤ 3 %	≤ 4 %
Phase shift ⁽²⁾	Not specified	≤ 2.2 °	≤ 2.2 °	≤ 1.5 °	-	-

- Bandwidth:**
DC .. 30 kHz at -3 dB (depending on current value)
- Insertion impedance:**
0.01 mΩ at 400 Hz, 0.12 mΩ at 1 kHz
- Maximum currents:**
3,000 A DC or 1,000 A AC continuous for a frequency < 1 kHz (limitation proportional to the inverse of one third of frequency beyond)
- DC zero adjustment:**
Automatic, in increments of 40 to 60 mA
- AC output noise:**
≤ 1 mV peak-to-peak
- Power supply:**
9 V alkaline (NEDA 1604A, IEC 6LR61)
5 V DC Micro USB type B
- Battery life:**
50 hours typical
- Consumption:**
Typical 10 mA (battery)
Typical 31 mA (5 V μUSB)
- "ON" LED indicator:**
"On" = In operation & battery level OK
"Flashing" = Battery life < 4 hours
"Colour = green" = APO ON
"Colour = yellow" = APO OFF
- "OL" LED indicator:**
Overload indication; current measured is too high for the calibre being used
- Effect of the power supply voltage:**
Null
- Influence of temperature:**
≤ 3 % of the measurement + 100 mA DC/°C
- Influence of relative humidity:**
≤ 0.5% at 10% to 85% RH at ambient temperature
- Influence of an adjacent conductor carrying a 50 Hz AC current, situated 23 mm from the clamp:**
< 10 mA/A
- Influence of an external field 400 A/m @ 50 Hz:**
< 1.3 A
- Influence of conductor position Ø 20 mm in jaws:**
≤ 1 %
- Influence of frequency ⁽³⁾:**
of 10 Hz .. 400 Hz: ≤ 1 % of Vs
of 400 Hz .. 10 kHz: ≤ 3.5 % of Vs
of 10 kHz .. 30 kHz: see curve
- Common mode rejection:**
> 90 dB A/V @ 50 Hz
- Remanence:**
0 to 50 A DC: 1.2 A typical
0 to 100 A DC: 2.3 A typical
0 to 200 A DC: 3.4 A typical
0 to 400 A DC: 4.8 A typical
0 to 600 A DC: 5.5 A typical
0 to 800 A DC: 5.8 A typical
- Output:**
1.5 m double-insulated lead with safety male plugs (4 mm)
- Dimensions:**
224 x 97 x 44 mm
- Mass:**
440 g with battery
- Operating temperature:**
-10°C to +55°C
- Storage temperature:**
-40°C to +80°C
- Max. temperature of clamped conductor (measured):**
+90 °C (+110 °C at peak)
- Max. jaw temperature:**
+80 °C
- Relative humidity for operation:**
0 to 85 % RH with a linear decrease above 35 °C
- Operating altitude:**
0 to 2,000 m
- Casing protection rating:**
IP 40 (IEC 60529)
- Drop test:**
1 m (IEC 60068-2-32)
- Self-extinguishing capability:**
UL94 V1
- Colours:**
Dark grey case with red jaws

Mechanical specifications

- Max. jaw opening:**
31 mm
- Clamping capacity:**
Cables: Ø 30 mm
Ø 24 mm x 2
Busbars: 1 busbar 50 x 10 mm
2 busbars 31.5 x 10 mm
3 busbars 25 x 8 mm
4 busbars 25 x 5 mm



CURRENT CLAMPS FOR AC/DC CURRENT

Model PAC15

Safety specifications

- Electrical safety:**
 Type A instrument, with double insulation or reinforced insulation between the primary, the secondary and the grippable part located under the guard as per CEI 61010-1 & CEI 61010-2-032
 - 600 V category III, pollution degree 2
 - 300 V category IV, pollution degree 2
- Electromagnetic compatibility (EMC):**
 Compliant with IEC 61326-1 (portable instrument)

Curves

Linearity with DC

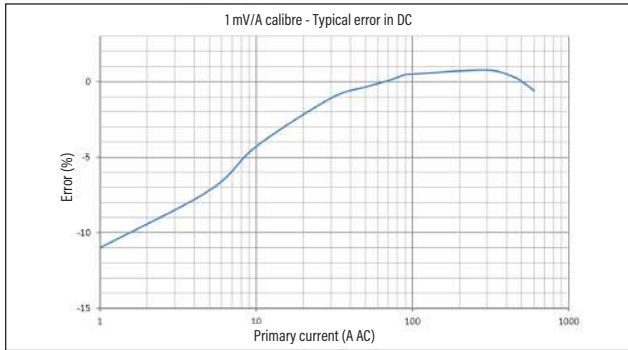

Linearity with AC

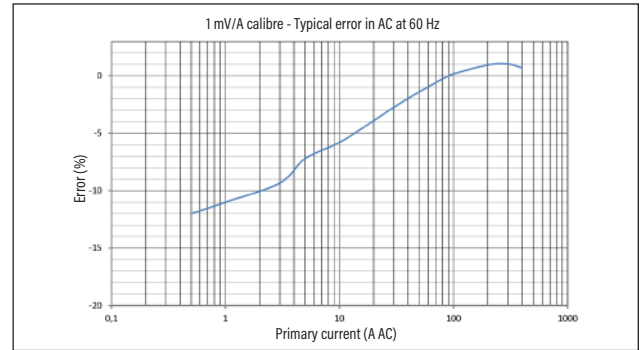

Phase shift

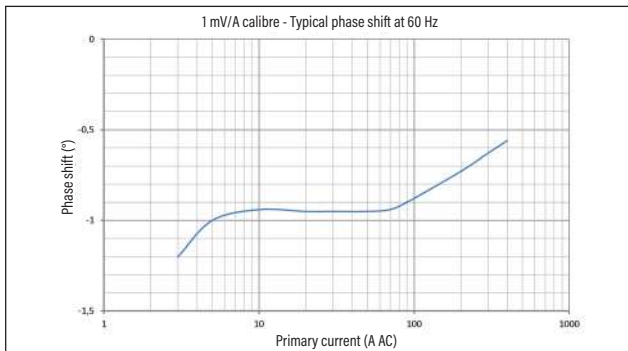

Limitation of measurable current according to frequency

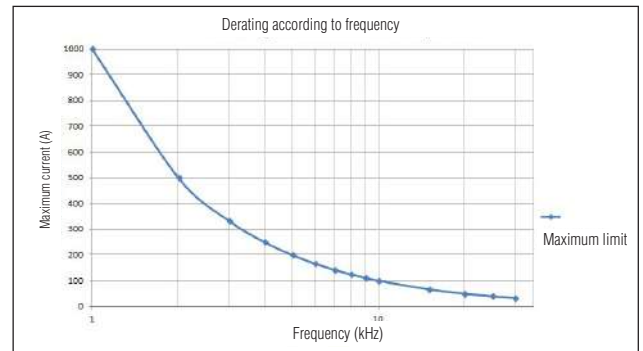

Frequency response

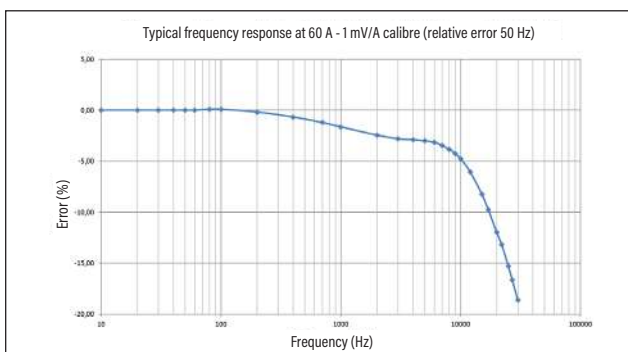

Frequency phase shift

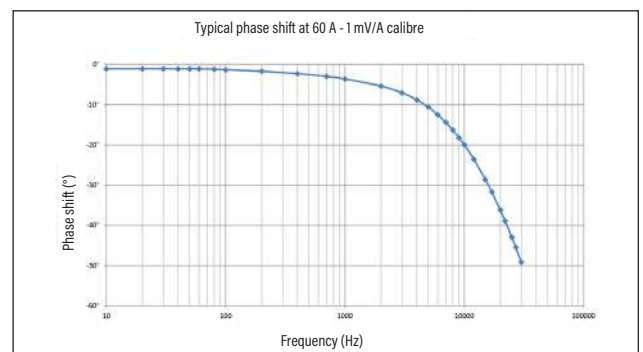

- (1) Conditions of reference:
 Temperature & humidity: 23 °C ± 5 °K, 20% to 75% RH
 Power supply: via a battery between 6 V and 9 V, via µUSB 5 ± 0.1 VDC
 Position of the conductor centred on the clamp markings
 Magnetic field: continuous Earth's magnetic field.
 No external alternating magnetic field.
 No electric field.
 Measurement for a sinusoidal DC current at 65 Hz.
 Instrument impedance: > 1 MΩ ≤ 100 pF.

(2) Phase shift in "absolute value" (unsigned)

(3) Out of reference domain

To order	Reference
AC/DC current clamps, model PAC15, with battery and user manual	P01120115

CURRENT CLAMP FOR AC/DC CURRENT

Model PAC16



Current	40 A AC 60 A DC	400 A AC 600 A DC
Output	10 mV/A	1 mV/A

Description

The PAC16 model provides accurate measurement of AC or DC currents using the Hall effect principle. This mV-output clamp meter is equipped with an automatic DC zero system and a disengageable Auto Power Off (APO) function, and can be powered by a standard mains adapter via a Micro USB connector.

Electrical specifications

- Current range:**
0.2 A AC .. 40 A AC (60 A peak) / 0.4 A DC .. 60 A DC
0.5 A AC .. 400 A AC (600 A peak) / 0.5 A DC .. 600 A DC
- Output signal:**
10 mV AC+ DC / A AC+ DC (0.6 V at 60 A)
1 mV AC+ DC / A AC+ DC (0.6 V at 600 A)
- Accuracy and phase shift ⁽¹⁾:**
- 60 A calibre

Primary current:	0.5 A .. 1 A	1 A .. 20 A	20 A .. 30 A	30 A .. 40 A	40 A .. 60 A (DC only)
Accuracy in % of output signal	≤ 3 % + 8 mV	≤ 3 % + 8 mV	≤ 3 % + 8 mV	≤ 1.5 %	≤ 1.5 %
Phase shift ⁽²⁾	Not specified	≤ 3°	≤ 2.2°	≤ 2.2°	-

- 600 A calibre

Primary current:	0.5 A .. 3 A	3 A .. 100 A	100 A .. 300 A	300 A .. 400 A	400 A .. 500 A (DC only)	500 A .. 600 A (DC only)
Accuracy in % of output signal	≤ 2 % + 1.5 mV	≤ 2 % + 1.5 mV	≤ 2 %	≤ 2 %	≤ 3 %	≤ 4 %
Phase shift ⁽³⁾	Not specified	≤ 2.2°	≤ 2.2°	≤ 1.5°	-	-

- Bandwidth:**
DC .. 30 kHz at -3 dB (depending on current value)
- Insertion impedance:**
0.01 mΩ at 400 Hz, 0.12 mΩ at 1 kHz
- Maximum currents:**
3,000 A DC or 1,000 A AC continuous for a frequency < 1 kHz (limitation proportional to the inverse of one third of frequency beyond)
- DC zero adjustment:**
Automatic, in increments of 40 to 60 mA
- AC output noise:**
- 60 A calibre: ≤ 3 mV or 0.3 A peak-peak
- 600 A calibre: ≤ 1 mV or 1 A peak-peak
- Power supply:**
9 V alkaline (NEDA 1604A, IEC 6LR61)
5 V DC Micro USB type B
- Battery life:**
50 hours typical
- Consumption:**
Typical 10 mA (battery)
Typical 31 mA (5 V μUSB)
- "ON" LED indicator:**
"On" = In operation & battery level OK
"Flashing" = Battery life < 4 hours
"Colour = green" = APO ON
"Colour = yellow" = APO OFF
- "OL" LED indicator:**
Overload indication; current measured is too high for the calibre being used
- Effect of the power supply voltage:**
Null
- Influence of temperature:**
≤ 3 % of the measurement + 100 mA DC/°C
- Influence of relative humidity:**
≤ 0.5% at 10% to 85% RH at ambient temperature
- Influence of an adjacent conductor carrying a 50 Hz AC current, situated 23 mm from the clamp:**
< 10 mA/A
- Influence of an external field 400 A/m @ 50 Hz:**
< 1.3 A
- Influence of conductor position**
Ø 20 mm in jaws:
≤ 1 %
- Influence of frequency ⁽⁴⁾:**
- Calibre 60 A: from 10 Hz .. 400 Hz: ≤ 1 % of Vs of 400 Hz .. 7 kHz: ≤ 3.5 % of Vs of 7 kHz .. 30 kHz: see curve
- Calibre 600 A: from 10 Hz .. 400 Hz: ≤ 1 % of Vs of 400 Hz .. 10 kHz: ≤ 3.5 % of Vs of 10 kHz .. 30 kHz: see curve
- Common mode rejection:**
> 90 dB A/V @ 50 Hz
- Remanence:**
0 to 50 A DC: 1.2 A typical
0 to 100 A DC: 2.3 A typical
0 to 200 A DC: 3.4 A typical
0 to 400 A DC: 4.8 A typical
0 to 600 A DC: 5.5 A typical
0 to 800 A DC: 5.8 A typical

Mechanical specifications

- Max. jaw opening:**
31 mm
- Clamping capacity:**
Cables: Ø 30 mm
Ø 24 mm x 2
Busbars: 1 busbar 50 x 10 mm
2 busbars 31.5 x 10 mm
3 busbars 25 x 8 mm
4 busbars 25 x 5 mm
- Output:**
1.5 m double-insulated lead with safety male plugs (4 mm)
- Dimensions:**
224 x 97 x 44 mm
- Mass:**
440 g with battery
- Operating temperature:**
-10°C to +55°C
- Storage temperature:**
-40°C to +80°C

CURRENT CLAMPS FOR AC/DC CURRENT

Model PAC16

- **Max. temperature of clamped conductor (measured):**
+90 °C (+110 °C at peak)
- **Max. jaw temperature:**
+80 °C
- **Relative humidity for operation:**
0 to 85 % RH with a linear decrease above 35 °C
- **Operating altitude:**
0 to 2,000 m
- **Casing protection rating:**
IP 40 (IEC 60529)
- **Drop test:**
1 m (IEC 60068-2-32)
- **Self-extinguishing capability:**
UL94 V1
- **Colours:**
Dark grey case with red jaws

Safety specifications

- **Electrical safety:**
Type A instrument, with double insulation or reinforced insulation between the primary, the secondary and the grippable part located under the guard as per CEI 61010-1 & CEI 61010-2-032
 - 600 V category III, pollution degree 2
 - 300 V category IV, pollution degree 2
- **Electromagnetic compatibility (EMC):** :
Compliant with IEC 61326-1 (portable instrument)

Curves

60 A calibre

Linearity with DC

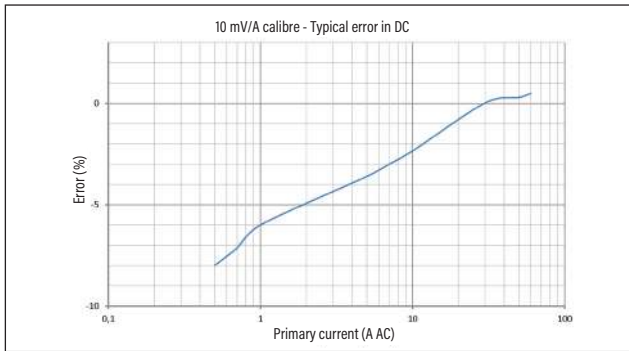

600 A calibre

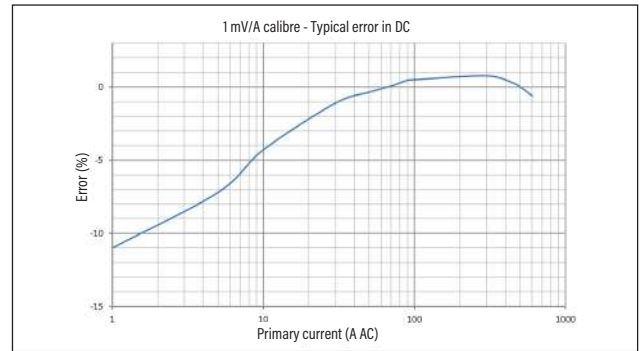

Linearity with AC

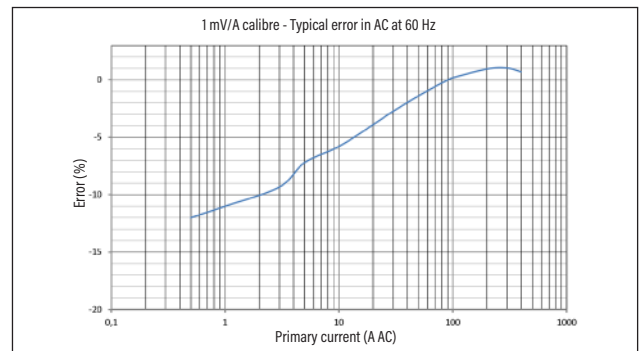
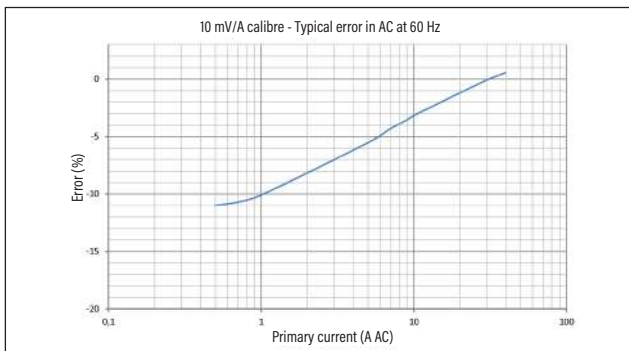

Phase shift

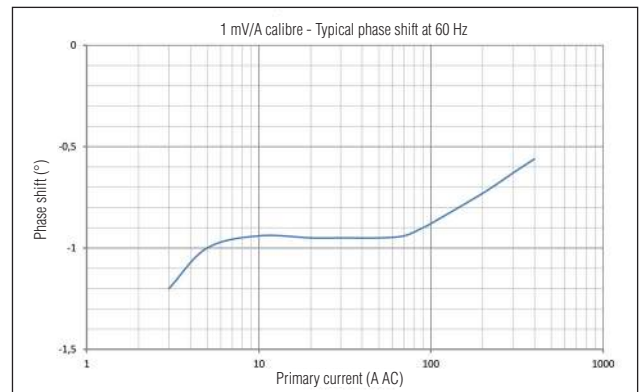

CURRENT CLAMP FOR AC/DC CURRENT

Model PAC16

Curves

Limitation of the measurable current as a function of frequency

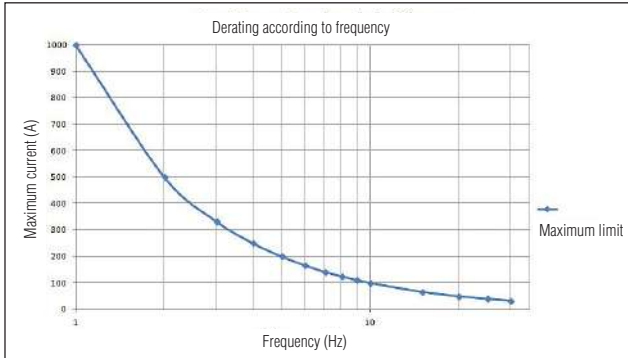

60 A calibre

600 A calibre

Frequency response

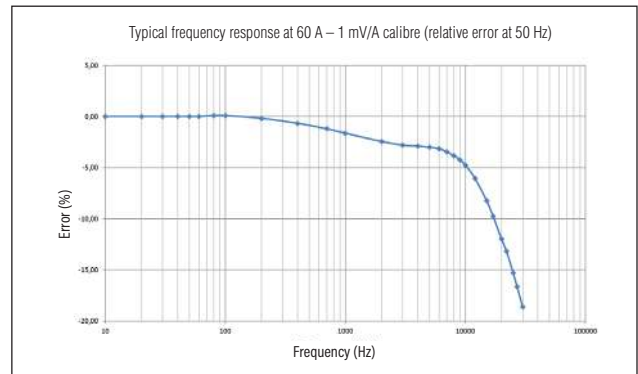
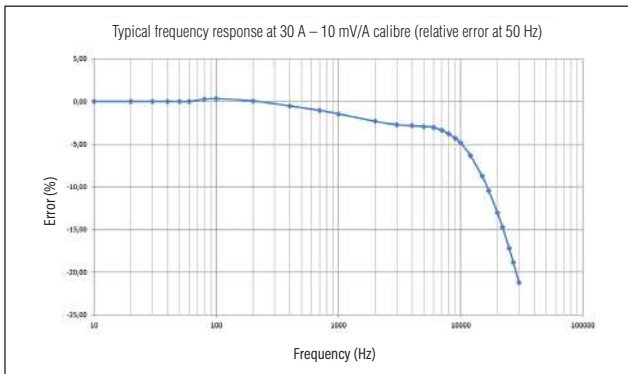

Frequency phase shift

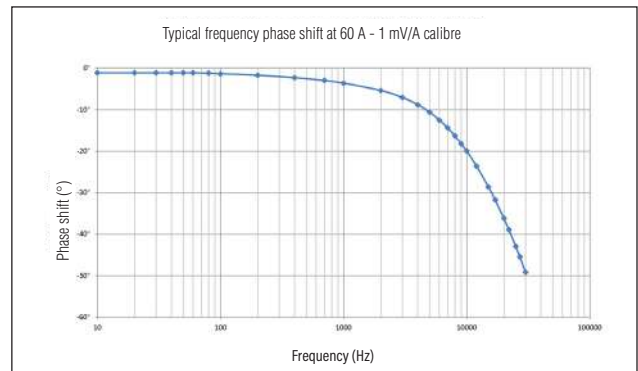
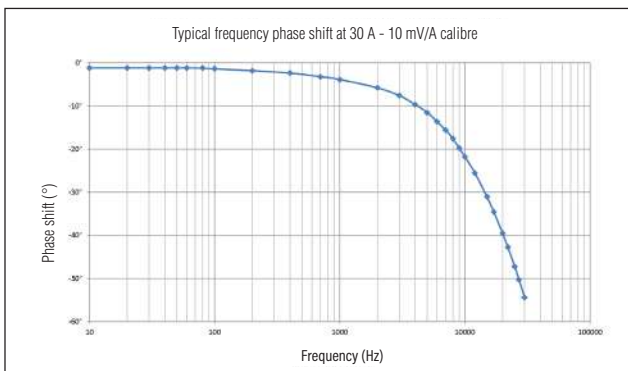

- (1) Conditions of reference:
 Temperature & humidity: 23 °C ± 5 °K, 20% to 75% RH
 Power supply: via a battery between 6 V and 9 V, via µUSB 5 ± 0.1 VDC
 Position of the conductor centred on the clamp markings
 Magnetic field: continuous Earth's magnetic field.
 No external alternating magnetic field.
 No electric field.
 Measurement for a sinusoidal DC current at 65 Hz.
 Instrument impedance: > 1 MΩ ≤ 100 pF.
- (2) Phase shift in "absolute value" (unsigned)
- (3) Out of reference domain

To order	Reference
AC/DC current clamps, model PAC16, with battery and user manual	P01120116

CURRENT CLAMPS FOR AC/DC CURRENT

Model PAC17 (insulated AC/DC current probe)

Current	40 A AC 60 A DC	400 A AC 600 A DC
Output	10 mV/A	1 mV/A

Description

The PAC17 model provides accurate measurement of AC or DC currents using the Hall effect principle. This mV-to-BNC output clamp (for direct reading on oscilloscopes, etc.) is equipped with an automatic DC zero system and a disengageable Auto Power Off (APO) function, and can be powered by a standard mains adapter via a Micro USB connector.

Electrical specifications

- Current range:**
0.2 A AC .. 40 A AC (60 A peak) / 0.4 A DC .. 60 A DC
0.5 A AC .. 400 A AC (600 A peak) / 0.5 A DC .. 600 A DC
- Output signal:**
10 mV AC+ DC / A AC+ DC (0.6 V at 60 A)
1 mV AC+ DC / A AC+ DC (0.6 V at 600 A)
- Accuracy and phase shift ⁽¹⁾:**
- 60 A calibre

Primary current:	0.5 A .. 1 A	1 A .. 20 A	20 A .. 30 A	30 A .. 40 A	40 A .. 60 A (DC only)
Accuracy in % of output signal	≤ 3 % + 8 mV	≤ 3 % + 8 mV	≤ 3 % + 8 mV	≤ 1.5 %	≤ 1.5 %
Phase shift ⁽²⁾	Not specified	≤ 3°	≤ 2.2°	≤ 2.2°	-

- 600 A calibre

Primary current:	0.5 A .. 3 A	3 A .. 100 A	100 A .. 300 A	300 A .. 400 A	400 A .. 500 A (DC only)	500 A .. 600 A (DC only)
Accuracy in % of output signal	≤ 2 % + 1.5 mV	≤ 2 % + 1.5 mV	≤ 2 %	≤ 2 %	≤ 3 %	≤ 4 %
Phase shift ⁽³⁾	Not specified	≤ 2.2°	≤ 2.2°	≤ 1.5°	-	-

- Bandwidth:**
DC .. 30 kHz at -3 dB (depending on current value)
- Rise time (10% to 90% of Vs):**
≤ 11 μs
- Fall time (from 90% to 10% of Vs):**
≤ 11 μs
- 10 % delay time:**
≤ 10 μs
- Insertion impedance:**
0.01 mΩ at 400 Hz, 2.8 mΩ at 10 kHz
- Maximum currents:**
3,000 A DC or 1,000 A AC continuous for a frequency < 1 kHz (limitation proportional to the inverse of one third of frequency beyond)
- DC zero adjustment:**
Calibre 60 A & 600 A:
Automatic, in increments of 40 to 60 mA
- AC output noise:**
 - 60 A calibre: ≤ 3 mV or 0.3 A peak-peak
 - 600 A calibre: ≤ 1 mV or 1 A peak-peak
- Power supply:**
9 V alkaline (NEDA 1604A, IEC 6LR61)
5 V DC Micro USB type B
- Battery life:**
50 hours typical
- Consumption:**
Typical 10 mA (battery)
Typical 31 mA (5 V μUSB)
- "ON" LED indicator:**
"On" = In operation & battery level OK
"Flashing" = Battery life < 4 hours

"Colour = green" = APO ON
"Colour = yellow" = APO OFF

- "OL" LED indicator:**
Overload indication; current measured is too high for the calibre being used
- Effect of the power supply voltage:**
Null
- Influence of temperature:**
≤ 3 % of the measurement + 100 mA DC/°C
- Influence of relative humidity:**
≤ 0.5% at 10% to 85% RH at ambient temperature
- Influence of an adjacent conductor carrying a 50 Hz AC current, situated 23 mm from the clamp:**
< 10 mA/A
- Influence of an external field 400 A/m @ 50 Hz:**
< 1.3 A
- Influence of conductor position Ø 20 mm in jaws:**
≤ 1 %
- Influence of frequency ⁽²⁾:**
 - Calibre 60 A: from 10 Hz .. 400 Hz: ≤ 1 % of Vs
of 400 Hz .. 7 kHz: ≤ 3.5 % of Vs
of 7 kHz .. 30 kHz: see curve
 - Calibre 600 A: from 10 Hz .. 400 Hz: ≤ 1 % of Vs
of 400 Hz .. 10 kHz: ≤ 3.5 % of Vs
of 10 kHz .. 30 kHz: see curve
- Common mode rejection:**
> 90 dB A/V @ 50 Hz

- Remanence:**
0 to 50 A DC: 1.2 A typical
0 to 100 A DC: 2.3 A typical
0 to 200 A DC: 3.4 A typical
0 to 400 A DC: 4.8 A typical
0 to 600 A DC: 5.5 A typical
0 to 800 A DC: 5.8 A typical

Mechanical specifications

- Max. jaw opening:**
31 mm
- Clamping capacity:**
Cables: Ø 30 mm
Ø 24 mm x 2
Busbars: 1 busbar 50 x 10 mm
2 busbars 31.5 x 10 mm
3 busbars 25 x 8 mm
4 busbars 25 x 5 mm
- Output:**
Coaxial cable 2 m long, terminated by an insulated BNC connector
- Dimensions:**
224 x 97 x 44 mm
- Mass:**
440 g with battery
- Operating temperature:**
-10°C to +55°C



CURRENT CLAMP FOR AC/DC CURRENT

Model PAC17 (insulated AC/DC current probe)

- **Storage temperature:**
-40°C to +80°C
- **Max. temperature of clamped conductor (measured):**
+90 °C (+110 °C at peak)
- **Max. jaw temperature:**
+80 °C
- **Relative humidity for operation:**
0 to 85 % RH with a linear decrease above 35 °C
- **Operating altitude:**
0 to 2,000 m
- **Casing protection rating:**
IP 40 (IEC 60529)
- **Drop test:**
1 m (IEC 60068-2-32)
- **Self-extinguishing capability:**
UL94 V1
- **Colours:**
Dark grey case with red jaws

Safety specifications

- **Electrical safety:**
Type A instrument, with double insulation or reinforced insulation between the primary, the secondary and the grippable part located under the guard as per CEI 61010-1 & CEI 61010-2-032
 - 600 V category III, pollution degree 2
 - 300 V category IV, pollution degree 2
- **Electromagnetic compatibility (EMC):** :
Compliant with IEC 61326-1 (portable instrument)

Curves

60 A calibre

Linearity with DC

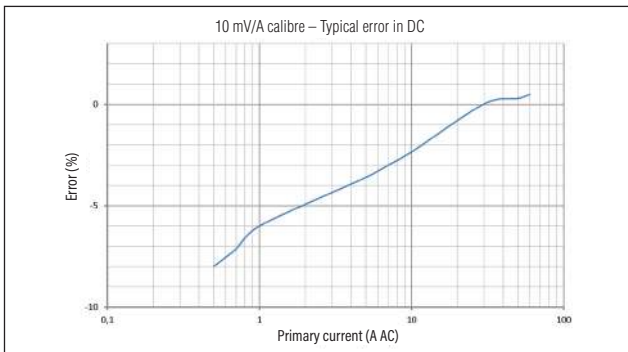

600 A calibre

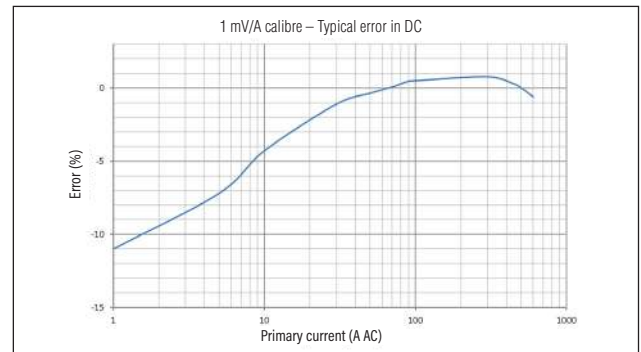

Linearity with AC

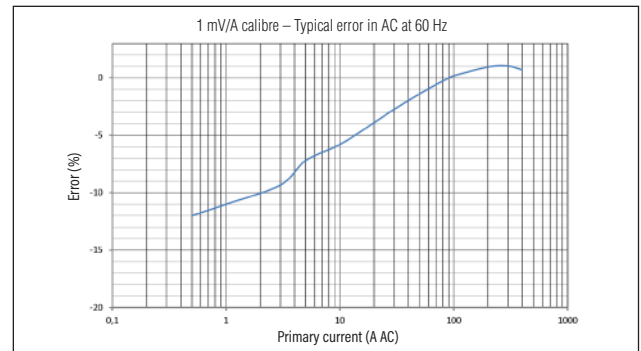
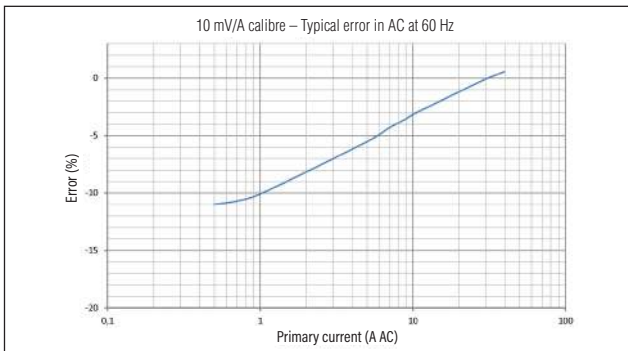

Phase shift

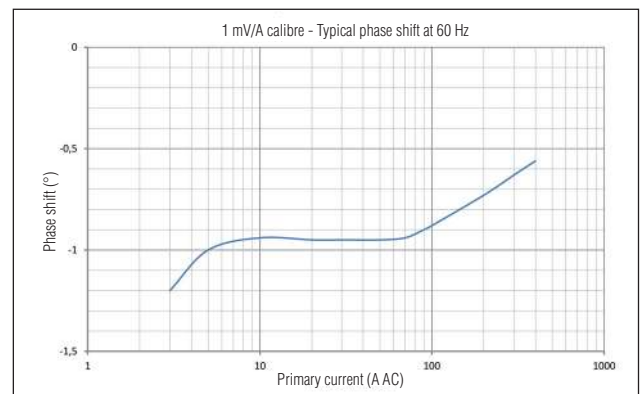

CURRENT CLAMPS FOR AC/DC CURRENT

Model PAC17 (insulated AC/DC current probe)

Curves

Limitation of the measurable current as a function of frequency

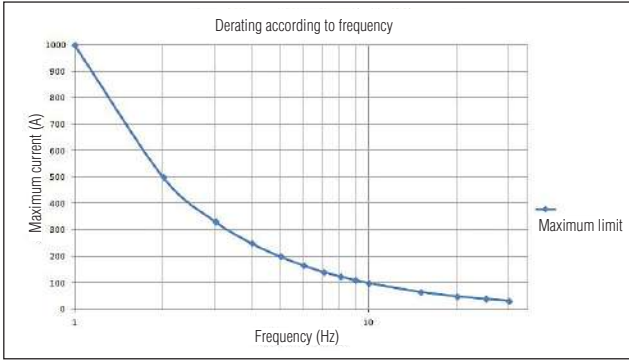

60 A calibre

600 A calibre

Frequency response

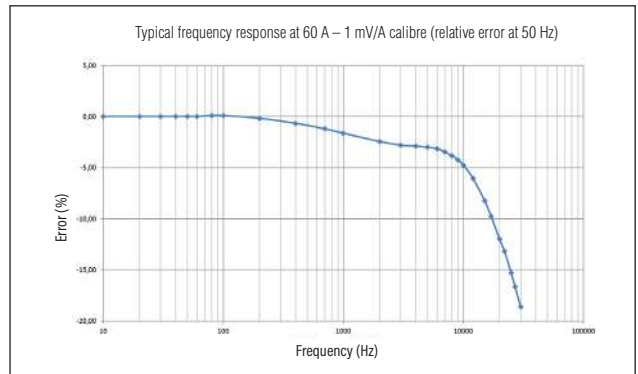
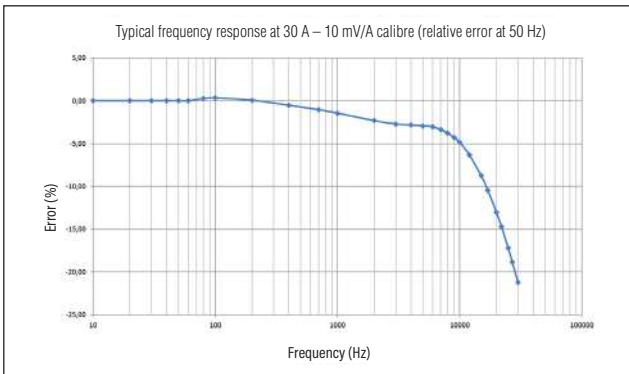

Frequency phase shift

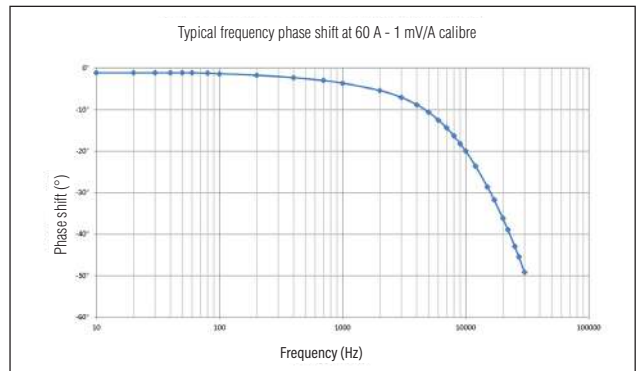
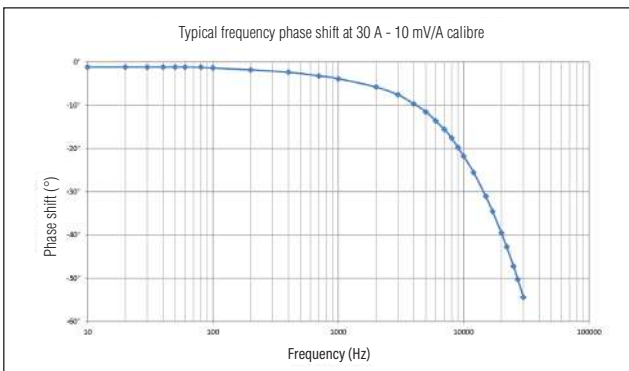

CURRENT CLAMP FOR AC/DC CURRENT

Model PAC17 (insulated AC/DC current probe)

Curves

60 A calibre

600 A calibre

Pulse response

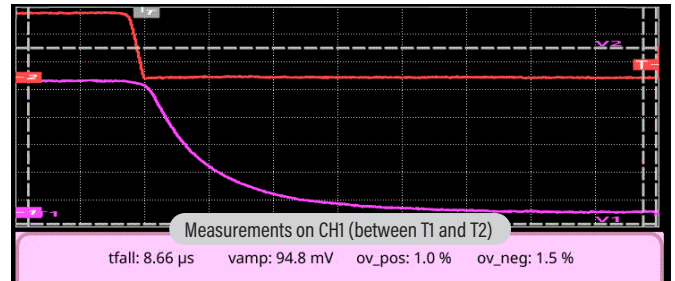
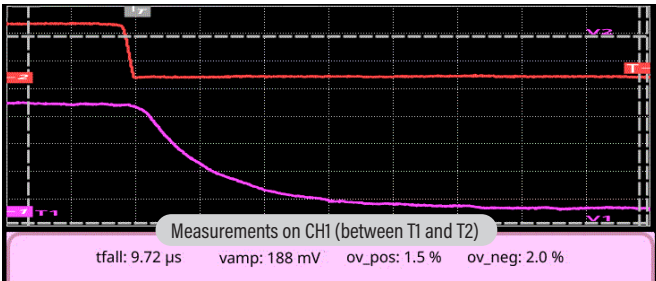
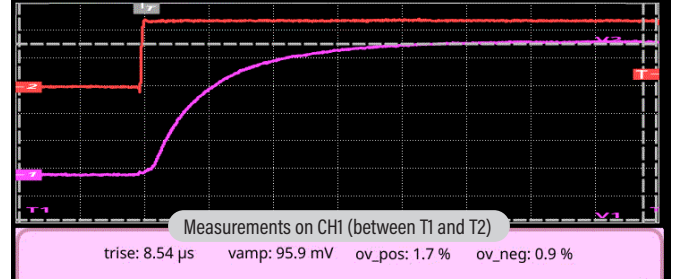
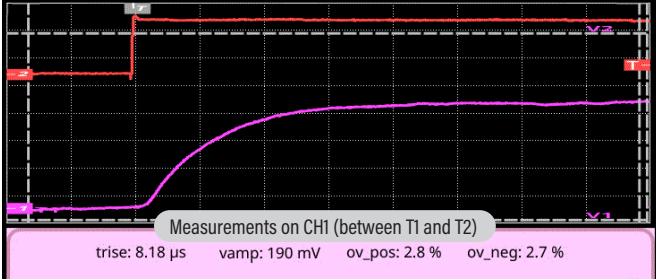

- (1) Conditions of reference:
 Temperature & humidity: 23 °C \pm 5 °K, 20% to 75% RH
 Power supply: via a battery between 6 V and 9 V, via μ USB 5 \pm 0.1 VDC
 Position of the conductor centred on the clamp markings
 Magnetic field: continuous Earth's magnetic field.
 No external alternating magnetic field.
 No electric field.
 Measurement for a sinusoidal DC current at 65 Hz.
 Instrument impedance: > 1 M Ω \leq 100 pF.
- (2) Out of reference domain

To order	Reference
AC/DC current clamp, model PAC17 , for oscilloscopes, with battery and operating user manual	P01120117

CURRENT CLAMPS FOR AC/DC CURRENT

Model PAC25

Current	1,000 A AC 1,400 A DC
Output	1 mV/A

Description

The PAC25 model provides accurate measurement of AC or DC currents using the Hall effect principle. This mV-output clamp meter is equipped with an automatic DC zero system and a disengageable Auto Power Off (APO) function, and can be powered by a standard mains adapter via a Micro USB connector.

Electrical specifications

- Current range**
0.5 A AC .. 1,000 A AC (1,400 A peak) / 0.5 A DC .. 1,400 A DC
- Output signal:**
1 mV AC+DC / A AC+DC (1.4 V for 1,400 A)
- Accuracy and phase shift ⁽¹⁾:**

Primary current:	0.5 A .. 3 A	3 A .. 100 A	100 A .. 200 A	200 A .. 800 A	800 A .. 1,000 A	1,000 A .. 1,400 A (DC only)
Accuracy in % of output signal	≤ 2% + 1.5 mV	≤ 2% + 1.5 mV	≤ 2.5%	≤ 2.5%	≤ 4%	≤ 5%
Phase shift ⁽²⁾	Not specified	≤ 2°	≤ 2°	≤ 1.5°	≤ 1.5°	-

- Bandwidth:**
DC .. 30 kHz at -3 dB (depending on current value)
- Insertion impedance:**
0.05 m at 400 Hz, 0.14 m at 1 kHz
- Maximum currents:**
3,000 A DC or 1,000 A AC continuous for a frequency < 1 kHz (limitation proportional to the inverse of one third of frequency beyond)
- DC zero adjustment:**
Automatic, in increments of 40 to 60 mA
- AC output noise:**
1 mV peak-peak
- Power supply:**
9 V alkaline (NEDA 1604A, IEC 6LR61)
5 V DC Micro USB type B
- Battery life:**
50 hours typical
- Consumption:**
Typical 10 mA (battery)
Typical 31 mA (5 V μ USB)
- "ON" LED indicator:**
"On" = In operation & battery level OK
"Flashing" = Battery life < 4 hours
"Colour = green" = APO ON
"Colour = yellow" = APO OFF
- "OL" LED indicator:**
Overload indication; current measured is too high for the calibre being used
- Effect of the power supply voltage:**
Null
- Influence of temperature:**
≤ 3 % of the measurement + 100 mA DC/°C
- Influence of relative humidity:**
0.5% at 10% to 85% RH at ambient temperature
- Influence of an adjacent conductor carrying a 50 Hz AC current, situated 23 mm from the clamp:**
< 10 mA/A
- Influence of an external field 400 A/m @ 50 Hz:**
< 1.3 A
- Influence of conductor position \varnothing 20 mm in jaws:**
0.5 %
- Influence of frequency ⁽²⁾:**
of 10 Hz .. 400 Hz: 1% of VS
of 400 Hz .. 10 kHz: 3.5 % of VS
of 10 kHz .. 30 kHz: see curve
- Common mode rejection:**
> 90 dB A/V @ 50 Hz
- Remanence:**
0 to 100 A DC: 2.8 A typical
0 to 200 A DC: 3.5 A typical
0 to 400 A DC: 5 A typical
0 to 800 A DC: 5.3 A typical
0 to 1,200 A DC: 5.7 A typical
0 to 1,400 A DC: 5.8 A typical
- Max. temperature of clamped conductor (measured):**
+90 °C (+110 °C at peak)
- Max. jaw temperature:**
+80 °C
- Relative humidity for operation:**
0 to 85 % RH with a linear decrease above 35 °C
- Operating altitude:**
0 to 2,000 m
- Casing protection rating:**
IP 40 (IEC 60529)
- Drop test:**
1 m (IEC 60068-2-32)
- Self-extinguishing capability:**
UL94 V1
- Colours:**
Dark grey case with red jaws

Mechanical specifications

- Max. jaw opening:**
39 mm
- Clamping capacity:**
Cables: \varnothing 39 mm
 \varnothing 25.4 mm x 2
Busbars: 1 busbar 50 x 12.5 mm
2 busbars 50 x 5 mm or 31.5 x 10 mm
3 busbars 25 x 8 mm
4 busbars 25 x 5 mm
- Output:**
1.5 m double-insulated lead with safety male plugs (4 mm)
- Dimensions:**
236.5 x 97 x 44 mm
- Mass:**
520 g with battery
- Operating temperature:**
-10°C to +55°C
- Storage temperature:**
-40°C to +80°C

Safety specifications

- Electrical safety:**
Type A instrument, with double insulation or reinforced insulation between the primary, the secondary and the grippable part located under the guard as per CEI 61010-1 & CEI 61010-2-032
- 600 V category III, pollution degree 2
- 300 V category IV, pollution degree 2
- Electromagnetic compatibility (EMC):** :
Compliant with IEC 61326-1 (portable instrument)



CURRENT CLAMP FOR AC/DC CURRENT

Model PAC25

Curves

Linearity for DC

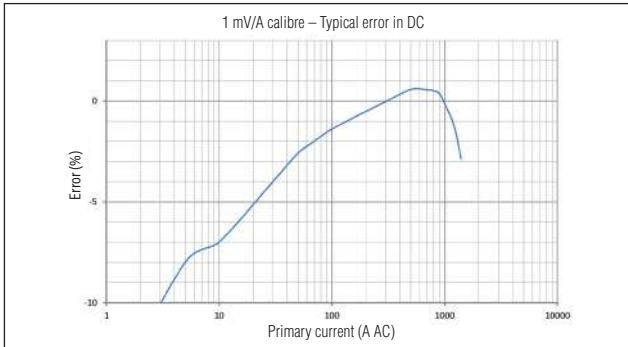

Linearity for AC

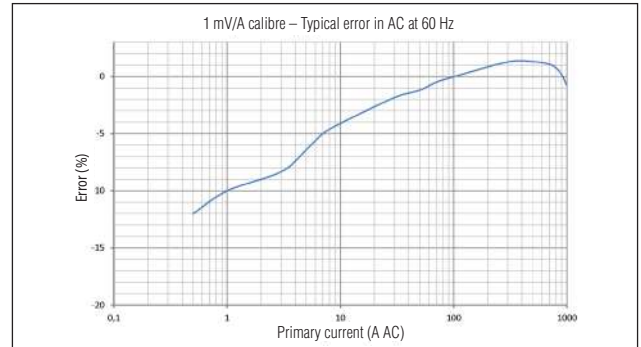

Phase shift

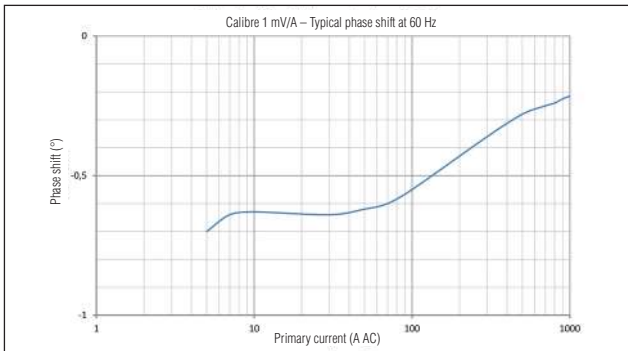

Limitation of the measurable current as a function of frequency

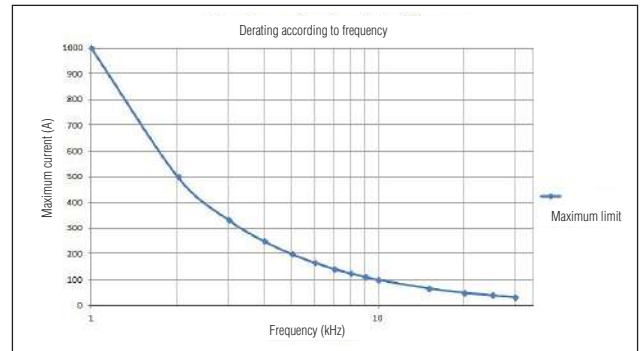

Frequency response

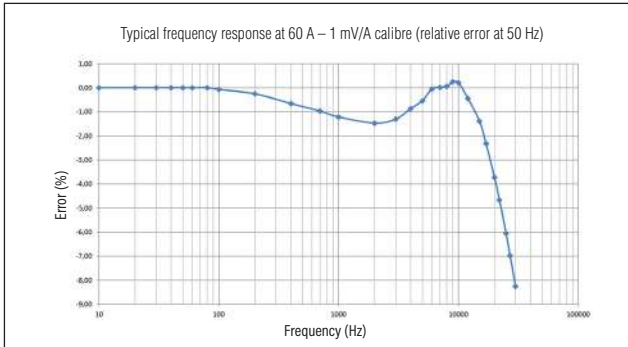

Frequency phase shift

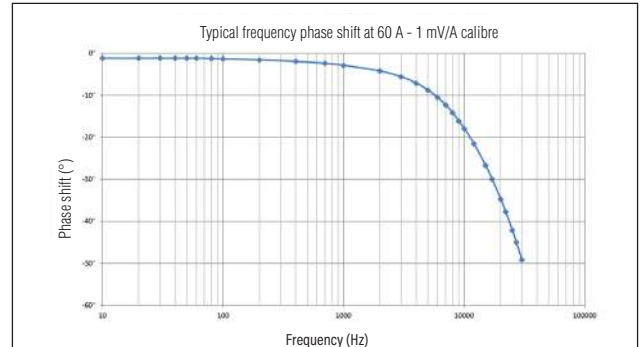

- (1) Conditions of reference:
 Temperature & humidity: 23 °C ± 5 °K, 20% to 75% RH
 Power supply: via a battery between 6 V and 9 V, via µUSB 5 ± 0.1 VDC
 Position of the conductor centred on the clamp markings
 Magnetic field: continuous Earth's magnetic field.
 No external alternating magnetic field.
 No electric field.
 Measurement for a sinusoidal DC current at 65 Hz.
 Instrument impedance: > 1 MΩ ≤ 100 pF.

- (2) Out of reference domain

To order	Reference
AC/DC current clamps, model PAC25, with battery and user manual	P01120125

CURRENT CLAMPS FOR AC/DC CURRENT

Model PAC26

Current	100 A AC 150 A DC	1,000 A AC 1,400 A DC
Output	10 mV/A	1 mV/A

Description

The PAC26 model provides accurate measurement of AC or DC currents using the Hall effect principle. This mV-output clamp meter is equipped with an automatic DC zero system and a disengageable Auto Power Off (APO) function, and can be powered by a standard mains adapter via a Micro USB connector.

Electrical specifications

- Current range:**
0.2 A AC .. 100 A AC (150 A peak) / 0.4 A DC .. 150 A DC
0.5 A AC .. 1,000 A AC (1,400 A peak) / 0.5 A DC .. 1,400 A DC
- Output signal:**
10 mV AC+ DC / A AC+ DC (0.6 V at 150 A)
1 mV AC+ DC / A AC+ DC (0.6 V at 1,400 A)
- Accuracy and phase shift ⁽¹⁾:**

- 150 A calibre

Primary current:	0.5 A .. 1 A	1 A .. 40 A	40 A .. 100 A	100 A .. 150 A (DC only)
Accuracy in % of output signal	≤ 3 % + 8 mV	≤ 3 % + 8 mV	≤ 1.5 %	≤ 1.5 %
Phase shift ⁽²⁾	Not specified	≤ 2°	≤ 2°	-

- 1,400 A calibre

Primary current:	0.5 A .. 3 A	3 A .. 100 A	100 A .. 200 A	200 A .. 800 A	800 A .. 1,000 A	1,000 A .. 1,400 A (DC only)
Accuracy in % of output signal	≤ 2 % + 1.5 mV	≤ 2 % + 1.5 mV	≤ 2.5 %	≤ 2.5 %	≤ 4 %	≤ 5 %
Phase shift ⁽³⁾	Not specified	≤ 2°	≤ 2°	≤ 1.5°	≤ 1.5°	-

- Bandwidth:**
DC .. 30 kHz at -3 dB (depending on current value)
- Insertion impedance:**
0.05 mΩ at 400 Hz, 0.14 mΩ at 1 kHz
- Maximum currents:**
3,000 A DC or 1,000 A AC continuous for a frequency < 1 kHz (limitation proportional to the inverse of one third of frequency beyond)
- DC zero adjustment:**
Automatic, in increments of 40 to 60 mA
- AC output noise:**
150 A calibre: ≤ 3 mV or 0.3 A peak-peak
1,400 A calibre: ≤ 1 mV or 1 A peak-peak
- Power supply:**
9 V alkaline (NEDA 1604A, IEC 6LR61)
5 V DC Micro USB type B
- Battery life:**
50 hours typical
- Consumption:**
Typical 10 mA (battery)
Typical 31 mA (5 V μUSB)
- "ON" LED indicator:**
"On" = In operation & battery level OK
"Flashing" = Battery life < 4 hours
"Colour = green" = APO ON
"Colour = yellow" = APO OFF
- "OL" LED indicator:**
Overload indication; current measured is too high for the calibre being used

- Effect of the power supply voltage:** Null
- Influence of temperature:**
≤ 3 % of the measurement + 100 mA DC/°C
- Influence of relative humidity:**
≤ 0.5% at 10% to 85% RH at ambient temperature
- Influence of an adjacent conductor carrying a 50 Hz AC current, situated 23 mm from the clamp:**
< 10 mA/A
- Influence of an external field 400 A/m @ 50 Hz:**
< 1.3 A
- Influence of conductor position Ø 20 mm in jaws:**
≤ 0.5 %
- Influence of frequency ⁽²⁾:**
 - Calibre 150 A: from 10 Hz .. 400 Hz: ≤ 1 % of Vs of 400 Hz .. 7 kHz: ≤ 3.5 % of Vs of 7 kHz .. 30 kHz: see curve
 - Calibre 1,400 A: from 10 Hz .. 400 Hz: ≤ 1 % of Vs of 400 Hz .. 10 kHz: ≤ 3.5 % of Vs of 10 kHz .. 30 kHz: see curve
- Common mode rejection:**
> 90 dB A/V @ 50 Hz
- Remanence:**
0 to 100 A DC: 2.8 A typical
0 to 200 A DC: 3.5 A typical
0 to 400 A DC: 5 A typical
0 to 800 A DC: 5.3 A typical
0 to 1,200 A DC: 5.7 A typical
0 to 1,400 A DC: 5.8 A typical

Mechanical specifications

- Max. jaw opening:**
39 mm
- Clamping capacity:**
Cables: Ø 39 mm
Ø 25.4 mm x 2
Busbars: 1 busbar 50 x 12.5 mm
2 busbars 50 x 5 mm or 31.5 x 10 mm
3 busbars 25 x 8 mm
4 busbars 25 x 5 mm
- Output:**
1.5 m double-insulated lead with safety male plugs (4 mm)
- Dimensions:**
236.5 x 97 x 44 mm
- Mass:**
520 g with battery
- Operating temperature:**
-10°C to +55°C
- Storage temperature:**
-40°C to +80°C



CURRENT CLAMP FOR AC/DC CURRENT

Model PAC26

- **Max. temperature of clamped conductor (measured):**
+90 °C (+110 °C at peak)
- **Max. jaw temperature:**
+80 °C
- **Relative humidity for operation:**
0 to 85 % RH with a linear decrease above 35 °C
- **Operating altitude:**
0 to 2,000 m
- **Casing protection rating:**
IP 40 (IEC 60529)
- **Drop test:**
1 m (IEC 60068-2-32)
- **Self-extinguishing capability:**
UL94 V1
- **Colours:**
Dark grey case with red jaws

Safety specifications

- **Electrical safety:**
Type A instrument, with double insulation or reinforced insulation between the primary, the secondary and the grippable part located under the guard as per CEI61010-1 & CEI 61010-2-032
- 600 V category III, pollution degree 2
- 300 V category IV, pollution degree 2
- **Electromagnetic compatibility (EMC):** :
Compliant with IEC 61326-1 (portable instrument)

Curves

150 A calibre

1,400 A calibre

Linearity for DC

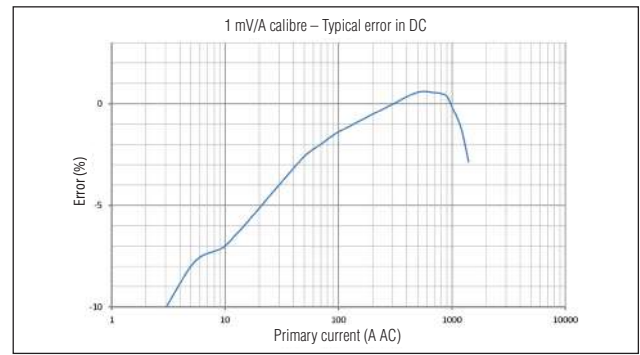
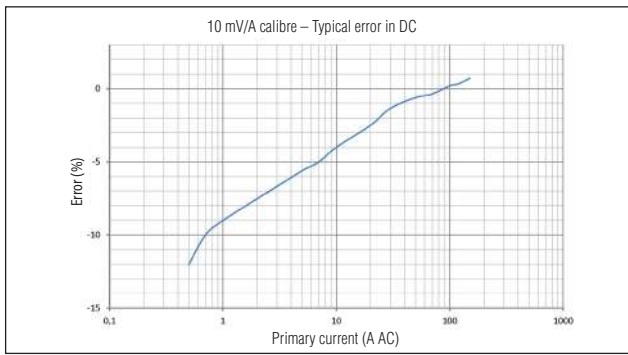

Linearity for AC

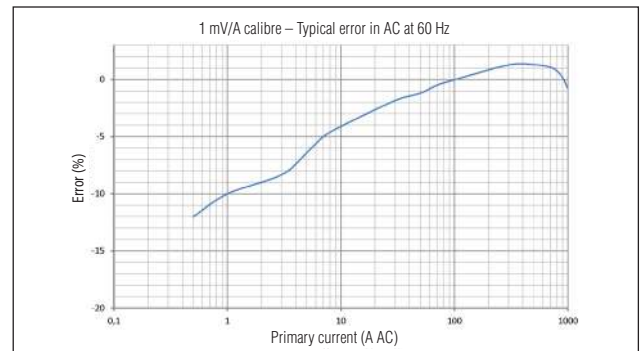
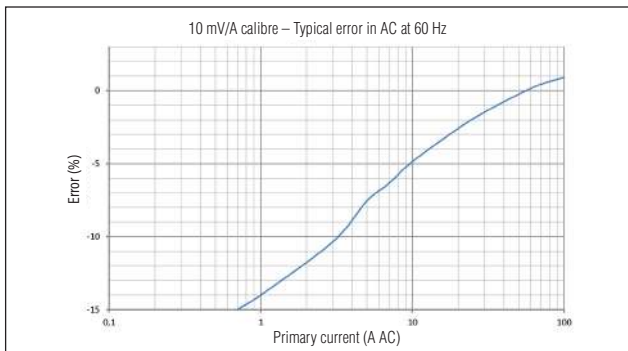

Phase shift

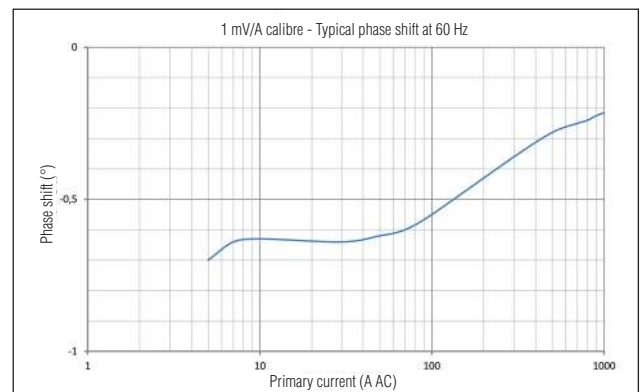

CURRENT CLAMPS FOR AC/DC CURRENT

Model PAC26

Curves

Limitation of the measurable current as a function of frequency

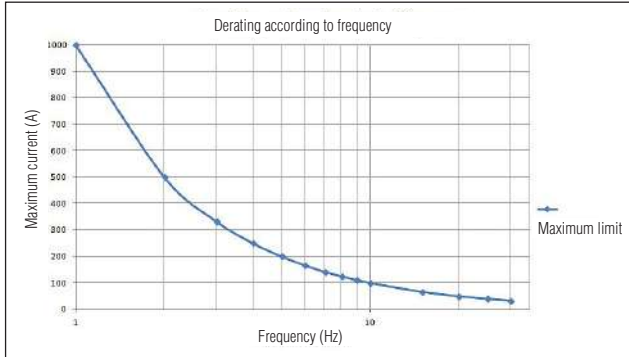

150 A calibre

1,400 A calibre

Frequency response

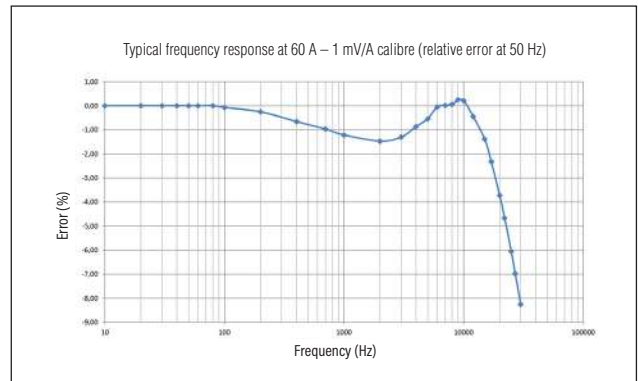
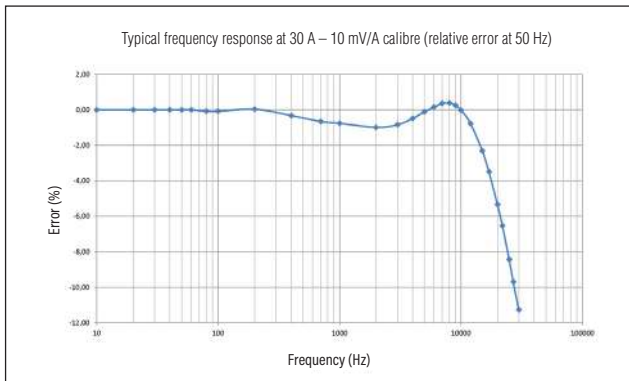

Frequency phase shift

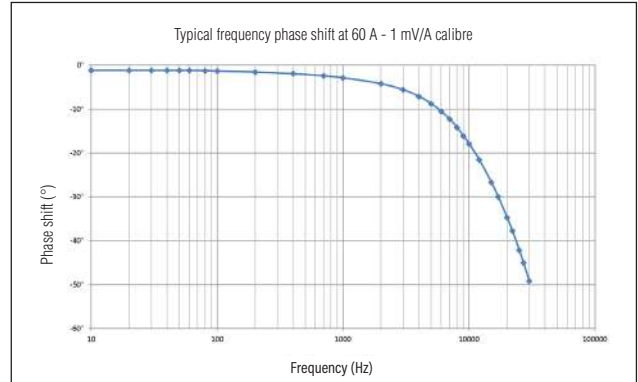
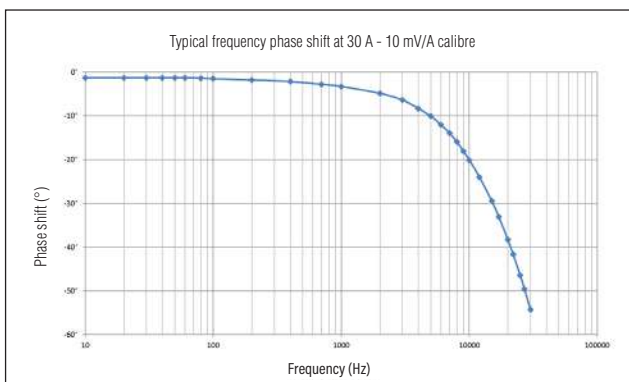

- (1) Conditions of reference:
 Temperature & humidity: 23 °C ± 5 °K, 20% to 75% RH
 Power supply: via a battery between 6 V and 9 V, via µUSB 5 ± 0.1 VDC
 Position of the conductor centred on the clamp markings
 Magnetic field: continuous Earth's magnetic field.
 No external alternating magnetic field.
 No electric field.
 Measurement for a sinusoidal DC current at 65 Hz.
 Instrument impedance: > 1 MΩ ≤ 100 pF.

- (2) Out of reference domain

To order	Reference
AC/DC current clamps, model PAC26, with battery and user manual	P01120126

CURRENT CLAMP FOR AC/DC CURRENT

Model PAC27 (insulated AC/DC current probe)

Current	100 A AC 150 A DC	1,000 A AC 1,400 A DC
Output	10 mV/A	1 mV/A

Description

The PAC27 model provides accurate measurement of AC or DC currents using the Hall effect principle. This mV-to-BNC output clamp (for direct reading on oscilloscopes, etc.) is equipped with an automatic DC zero system and a disengageable Auto Power Off (APO) function, and can be powered by a standard mains adapter via a Micro USB connector.

Electrical specifications

- Current range:**
0.2 A AC .. 100 A AC (150 A peak) / 0.4 ADC .. 150 A DC
0.5 A AC .. 1,000 A AC (1,400 A peak) / 0.5 ADC .. 1,400 A DC
- Output signal:**
1 mV AC+DC / A AC+DC (1.4 V for 1,400 A)
- Accuracy and phase shift ⁽¹⁾:**
- 150 A calibre

Primary current:	0.5 A .. 1 A	1 A .. 40 A	40 A .. 100 A	100 A .. 150 A (DC only)
Accuracy in % of output signal	≤ 3 % + 8 mV	≤ 3 % + 8 mV	≤ 1.5 %	≤ 1.5 %
Phase shift ⁽²⁾	Not specified	≤ 2°	≤ 2°	-

- 1,400 A calibre

Primary current:	0.5 A .. 3 A	3 A .. 100 A	100 A .. 200 A	200 A .. 800 A	800 A .. 1,000 A	1,000 A .. 1,400 A (DC only)
Accuracy in % of output signal	≤ 2 % + 1.5 mV	≤ 2 % + 1.5 mV	≤ 2.5 %	≤ 2.5 %	≤ 4 %	≤ 5 %
Phase shift ⁽³⁾	Not specified	≤ 2°	≤ 2°	≤ 1.5°	≤ 1.5°	-

- Bandwidth:**
DC .. 30 kHz at -3 dB (depending on current value)
- Rise time (10% to 90% of Vs)**
≤ 11 μs
- Fall time (90% to 10% of Vs)**
≤ 11 μs
- 10 % delay time:**
≤ 10 μs
- Insertion impedance:**
0.05 mΩ at 400 Hz, 3.4 mΩ at 10 kHz
- Maximum currents:**
3,000 A DC or 1,000 A AC continuous for a frequency < 1 kHz (limitation proportional to the inverse of one third of frequency beyond)
- DC zero adjustment:**
Calibre 150 A & 1,400 A:
Automatic, in increments of 40 to 60 mA
- AC output noise:**
 - 150 A calibre: ≤ 3 mV or 0.3 A peak-peak
 - 1,400 A calibre: ≤ 1 mV or 1 A peak-peak
- Power supply:**
9 V alkaline (NEDA 1604A, IEC 6LR61)
5 V DC Micro USB type B
- Battery life:**
50 hours typical
- Consumption:**
Typical 10 mA (battery)
Typical 31 mA (5 V μUSB)
- "ON" LED indicator:**
"On" = In operation & battery level OK
"Flashing" = Battery life < 4 hours
"Colour = green" = APO ON
"Colour = yellow" = APO OFF
- "OL" LED indicator:**
Overload indication; current measured is too high for the calibre being used
- Effect of the power supply voltage:**
Null
- Influence of temperature:**
≤ 3 % of the measurement + 100 mA DC/°C
- Influence of relative humidity:**
≤ 0.5% at 10% to 85% RH at ambient temperature
- Influence of an adjacent conductor carrying a 50 Hz AC current, situated 23 mm from the clamp:**
< 10 mA/A
- Influence of an external field 400 A/m @ 50 Hz:**
< 1.3 A
- Influence of conductor position Ø 20 mm in jaws:**
≤ 0.5 %
- Influence of frequency ⁽²⁾:**
 - Calibre 150 A: from 10 Hz .. 400 Hz: ≤ 1 % of Vs
of 400 Hz .. 7 kHz: ≤ 3.5 % of Vs
of 7 kHz .. 30 kHz: see curve
 - Calibre 1,400 A: from 10 Hz .. 400 Hz: ≤ 1 % of Vs
of 400 Hz .. 10 kHz: ≤ 3.5 % of Vs
of 10 kHz .. 30 kHz: see curve
- Common mode rejection:**
> 90 dB A/V @ 50 Hz
- Remanence:**
0 to 100 A DC: 2.8 A typical
0 to 200 A DC: 3.5 A typical
0 to 400 A DC: 5 A typical
0 to 800 A DC: 5.3 A typical
0 to 1,200 A DC: 5.7 A typical
0 to 1,400 A DC: 5.8 A typical



Mechanical specifications

- Max. jaw opening:**
39 mm
- Clamping capacity:**
Cables: Ø 39 mm
Ø 25.4 mm x 2
Busbars: 1 busbar 50 x 12.5 mm
2 busbars 50 x 5 mm or 31.5 x 10 mm
3 busbars 25 x 8 mm
4 busbars 25 x 5 mm
- Output:**
Coaxial cable 2 m long, terminated by an insulated BNC connector
- Dimensions:**
236.5 x 97 x 44 mm

CURRENT CLAMPS FOR AC/DC CURRENT

Model PAC27 (insulated AC/DC current probe)

- **Mass:**
520 g with battery
- **Operating temperature:**
-10°C to +55°C
- **Storage temperature:**
-40°C to +80°C
- **Max. temperature of clamped conductor (measured):**
+90 °C (+110 °C at peak)
- **Max. jaw temperature:**
+80 °C
- **Relative humidity for operation:**
0 to 85 % RH with a linear decrease above 35 °C
- **Operating altitude:**
0 to 2,000 m
- **Casing protection rating:**
IP 40 (IEC 60529)
- **Drop test:**
1 m (IEC 60068-2-32)
- **Self-extinguishing capability:**
UL94 V1
- **Colours:**
Dark grey case with red jaws

Safety specifications

- **Electrical safety:**
Type A instrument, with double insulation or reinforced insulation between the primary, the secondary and the grippable part located under the guard as per CEI 61010-1 & CEI 61010-2-032
- 600 V category III, pollution degree 2
- 300 V category IV, pollution degree 2
- **Electromagnetic compatibility (EMC):** :
Compliant with IEC 61326-1 (portable instrument)

Curves

150 A calibre

1,400 A calibre

Linearity for DC

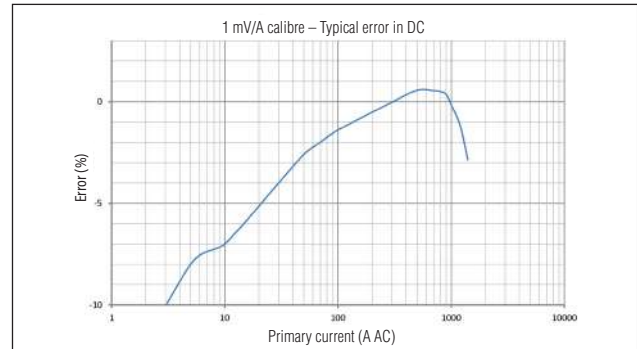
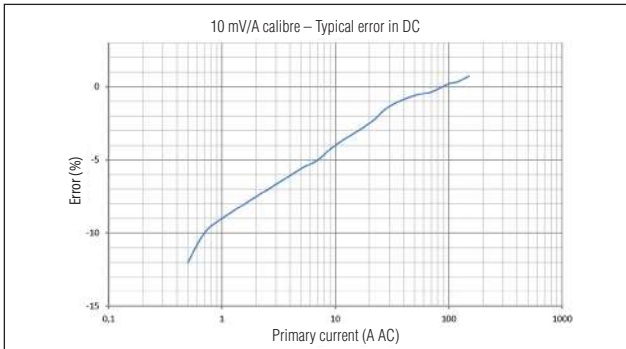

Linearity for AC

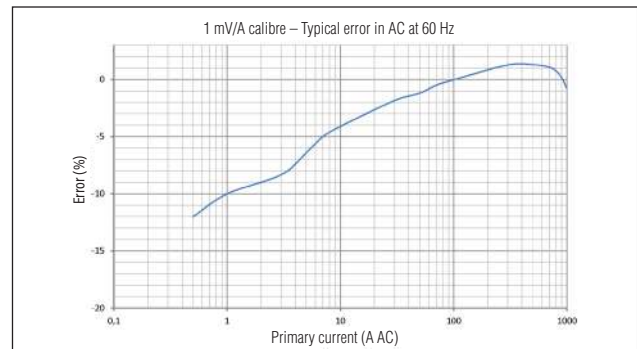
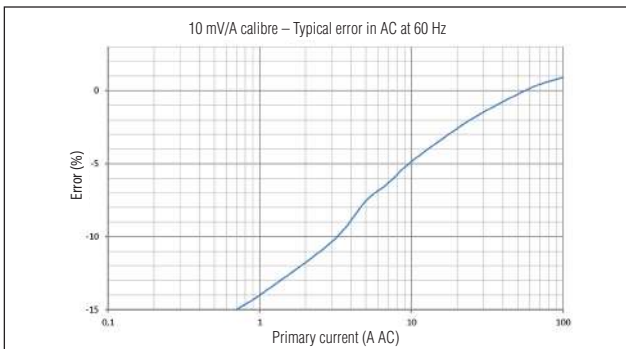

Phase shift

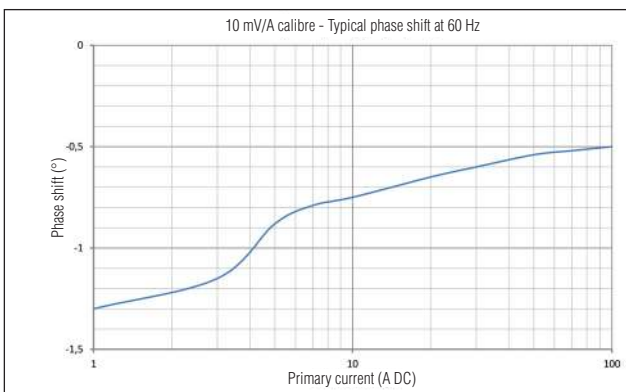

CURRENT CLAMP FOR AC/DC CURRENT

Model PAC27 (insulated AC/DC current probe)

Curves

Limitation of the measurable current as a function of frequency

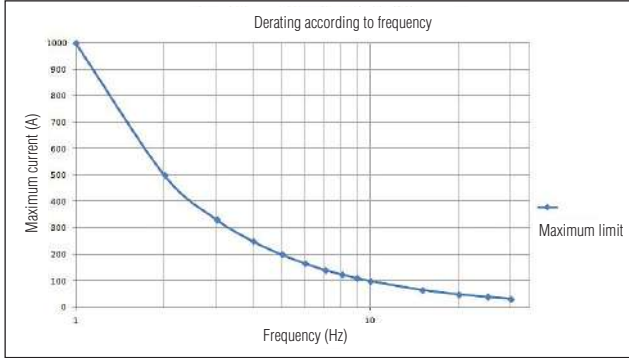

150 A calibre

1,400 A calibre

Frequency response

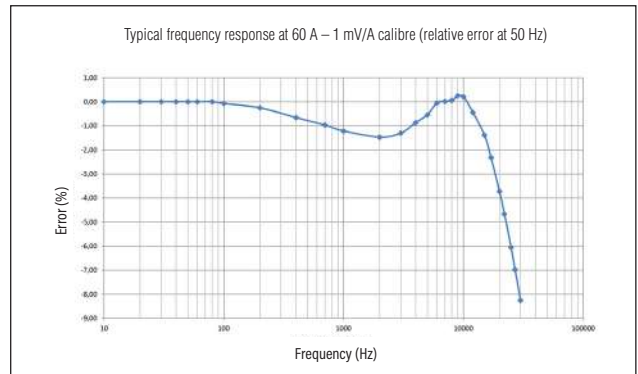
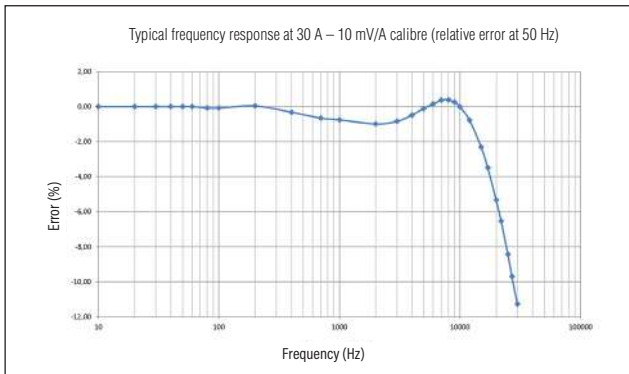

Frequency phase shift

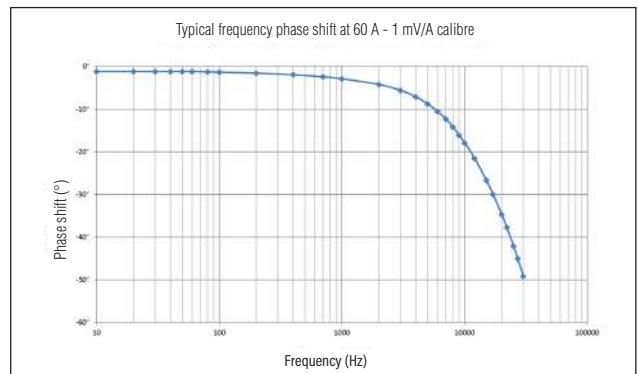
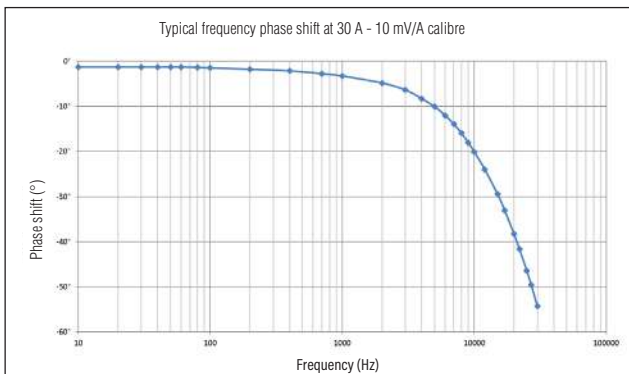

CURRENT CLAMPS FOR AC/DC CURRENT

Model PAC27 (insulated AC/DC current probe)

Curves

150 A calibre

1,400 A calibre

Pulse response

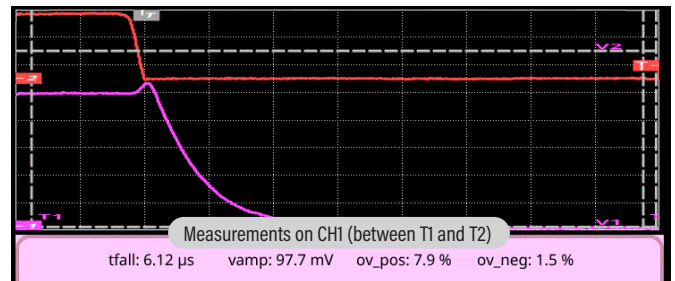
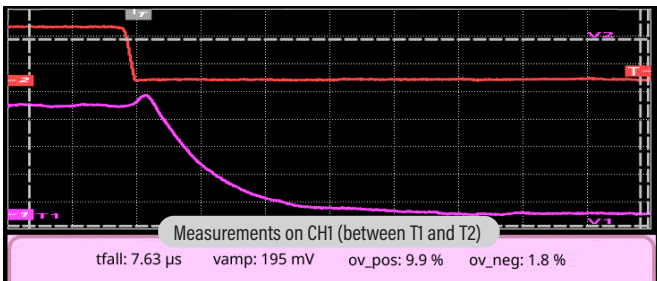
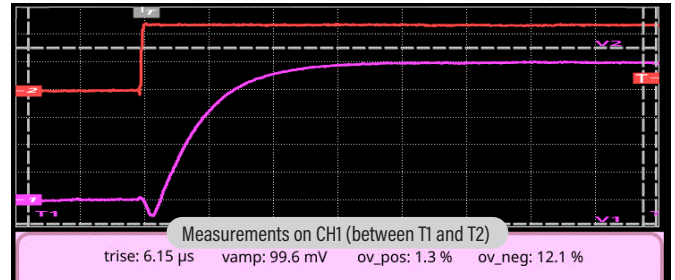
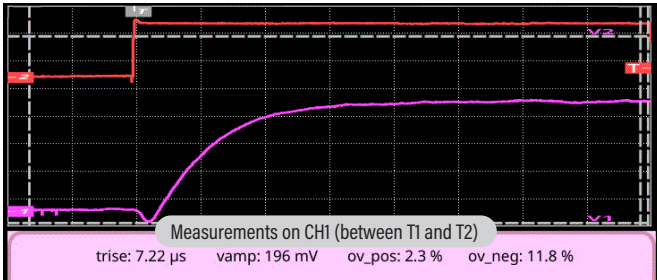

- (1) Conditions of reference:
- Temperature & humidity: 23 °C \pm 5 °K, 20% to 75% RH
 - Power supply: via a battery between 6 V and 9 V, via μ USB 5 \pm 0.1 VDC
 - Position of the conductor centred on the clamp markings
 - Magnetic field: continuous Earth's magnetic field.
 - No external alternating magnetic field.
 - No electric field.
 - Measurement for a sinusoidal DC current at 65 Hz.
 - Instrument impedance: > 1 M Ω \leq 100 pF.
- (2) Out of reference domain

To order	Reference
AC/DC current clamp, model PAC27 , for oscilloscopes, with battery and operating user manual	P01120127

ACCESSORIES



Clamp accessories

Having made test, control and measurement instruments for over a century now, Chauvin Arnoux products are the result of years of experience in the field. A knowledge of measurement techniques and daily experience in safety practices has led to the development of an entire range of practical and safety-conscious test accessories.

From the BNC/socket female adapter Ø 4 mm to the silicone lead with straight or elbowed banana leads, there is one key requirement: compliance with the IEC 61010 standard.

However, even a device that complies with this standard does not guarantee complete safety, so make sure that you are equipped with suitable accessories with which you can verify that your equipment meets the most demanding safety standards.

MAINS ADAPTERS - CABLES

Mains adapters

For unlimited operation of your current clamps, replace the battery with the mains adapter.

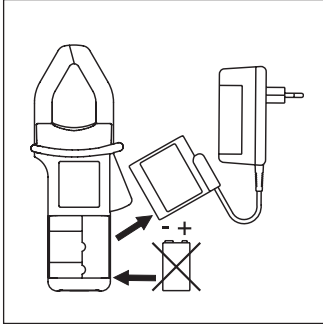

For PAC 10, 11, 12 and PAC 20, 21, 22 clamps

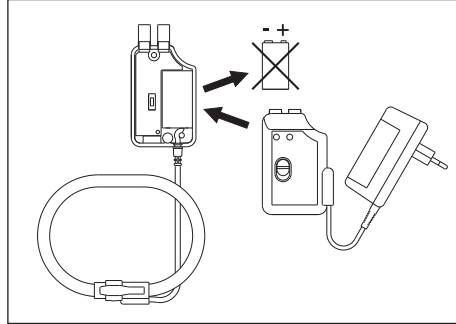

For AmpFlex® A100 clamp, MiniFlex MA100clamp and K clamp



For MiniFlex MA110 clamp, MiniFlex MA130 clamp, AmpFlex® A110, AmpFlex® A130 clamp, MH60 clamp and PAC 15, 16, 17 et PAC 25, 26, 27 clamps

To order	Reference
Mains adapter for E1N, E3N, E6N clamps	P01101965
Mains adapter for K clamp	P01101966
Mains adapter for PAC 10, 11, 12 and PAC 20, 21, 22 clamps	P01101967
Mains adapter for AmpFlex® A100	P01101968
Mains adapter for MiniFlex MA100	P01102086
Mains adapter for MiniFlex MA200	P01102087
Mains adapter for MiniFlex MA110, MiniFlex MA130, AmpFlex® A110, AmpFlex® A130 and E25, E27, MH60, PAC 15, 16, 17 and PAC 25, 26, 27	P01651023

Leads and adapters



1

- Standard PVC leads
 - Straight male plug Ø 4 mm
 - Elbowed male plug Ø 4 mm
 - 15 A / 1.5 m
 - 1,000 V CAT IV
 - 1,500 V CAT III



2

- BNC / banana adapter
 - Insulated male BNC
 - Insulated male banana sockets, Ø 4 mm with 19 mm spacing
 - 500 V CAT I
 - 150 V CAT III

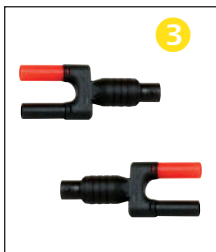

3

- BNC/banana adapter
 - Insulated female BNC
 - Insulated male banana plugs, Ø 4 mm with 19 mm spacing
 - 600 V CAT III



4

- BNC / banana adapter
 - Insulated male plugs BNC
 - Insulated female banana plugs Ø 4 mm with 19 mm spacing
 - 600 V CAT III

To order	Reference
1 Standard PVC leads (1 red + 1 black)	P01295289Z
2 Male BNC / Male bananas adapter (set of 2)	P01101847
3 Female BNC / Isolated male bananas adapter (set of 2)	P01102101Z
4 Male BNC / Female bananas adapter (set of 2)	HX0107

A NETWORK OF LOCAL BRANCHES

LILLE

Tel.: +33 (0) 320 559 641
info@chauvin-arnoux.com

LYON

Tel.: +33 (0) 472 657 760
info@chauvin-arnoux.com

PARIS

Tel.: +33 (0) 144 854 485
info@chauvin-arnoux.com

MARSEILLE

Tel.: +33 (0) 472 657 762
info@chauvin-arnoux.com

10 SUBSIDIARIES SPREAD ACROSS THE WORLD

GERMANY

Chauvin Arnoux GmbH

Ohmstrasse 1
77694 Kehl / Rhein - Germany
Tel.: +49 7851 99 26-0
info@chauvin-arnoux.de
www.chauvin-arnoux.de

AUSTRIA

Chauvin Arnoux GesmbH

Gastgebgsasse 27
AT-1230 Wien - Austria
Tel.: +43 1 61 61 9 61
vie-office@chauvin-arnoux.at
www.chauvin-arnoux.at

CHINA

Shanghai Pujiang Enerdis Instruments

Co Ltd

Gemdale Viseen Minhang Technology & Industrial Park Project 3 Floor, 23 Building
1288 Zhongchun RD, Minhang District
Shanghai 201199 - China
Tel.: +86 21 65 21 51 96
info@chauvin-arnoux.com.cn
www.chauvin-arnoux.com

SPAIN

Chauvin Arnoux Ibérica S.A.

C/ Roger de Flor n°293 - 1a Planta
08025 Barcelona - Spain
Tel.: +34 902 20 22 26
comercial@chauvin-arnoux.es
www.chauvin-arnoux.es

ITALY

AMRA

Via Sant'Amrogio, 23
20846 Macherio (MB) - Italia
Tel.: +39 039 245 75 45
info@amra-chauvin-arnoux.it
www.chauvin-arnoux.it

MIDDLE EAST

Chauvin Arnoux Middle East

PO Box 60-154
1241 2020 Beirut - Lebanon
Tel.: +961 1 890 425
camie@chauvin-arnoux.com
www.chauvin-arnoux.com

UNITED KINGDOM

Chauvin Arnoux Ltd

Unit 1 Nelson Ct, Flagship Sq Shaw Cross
Business Pk
WF127 TH Dewsbury West Yorkshire - UK
Tel.: +44 1924 460 494
info@chauvin-arnoux.co.uk
www.chauvin-arnoux.com

SCANDINAVIA

CA Mätssystem AB

Sjöflygvägen 35
SE-183 62 Taby - Sweden
Tel.: +46 8 50 52 68 00
info@camatsystem.com
www.camatsystem.com

SWITZERLAND

Chauvin Arnoux AG

Moosacherstrasse 15
8804 AU
Zurich - Switzerland
Tel.: +41 44 727 75 55
info@chauvin-arnoux.ch
www.chauvin-arnoux.ch

USA

Chauvin Arnoux Inc

d.b.a AEMC Instruments
15 Faraday Drive
NH 03820 Dover - USA
Tel.: +1 (603) 749-6434 (Ext. 520)
sales@aemc.com
www.aemc.com

INTERNATIONAL Chauvin Arnoux

12-16, rue Sarah Bernhardt
92600 Asnières-sur-Seine
Tel.: +33 1 44 85 44 38
export@chauvin-arnoux.fr
www.chauvin-arnoux.com

FRANCE

Chauvin Arnoux
12-16, rue Sarah Bernhardt
92600 Asnières-sur-Seine
Tel.: +33 1 44 85 44 85
info@chauvin-arnoux.fr
www.chauvin-arnoux.fr

SWITZERLAND

Chauvin Arnoux AG
Moosacherstrasse 15
8804 AU / ZH
Tel.: +41 44 727 75 55
info@chauvin-arnoux.ch
www.chauvin-arnoux.ch

LEBANON

Chauvin Arnoux Middle East
PO Box 60-154
1241 2020 Beirut
Tel.: +961 1 890 425
camie@chauvin-arnoux.com
www.chauvin-arnoux.com

